

MONOLITH

Design Planning Guide

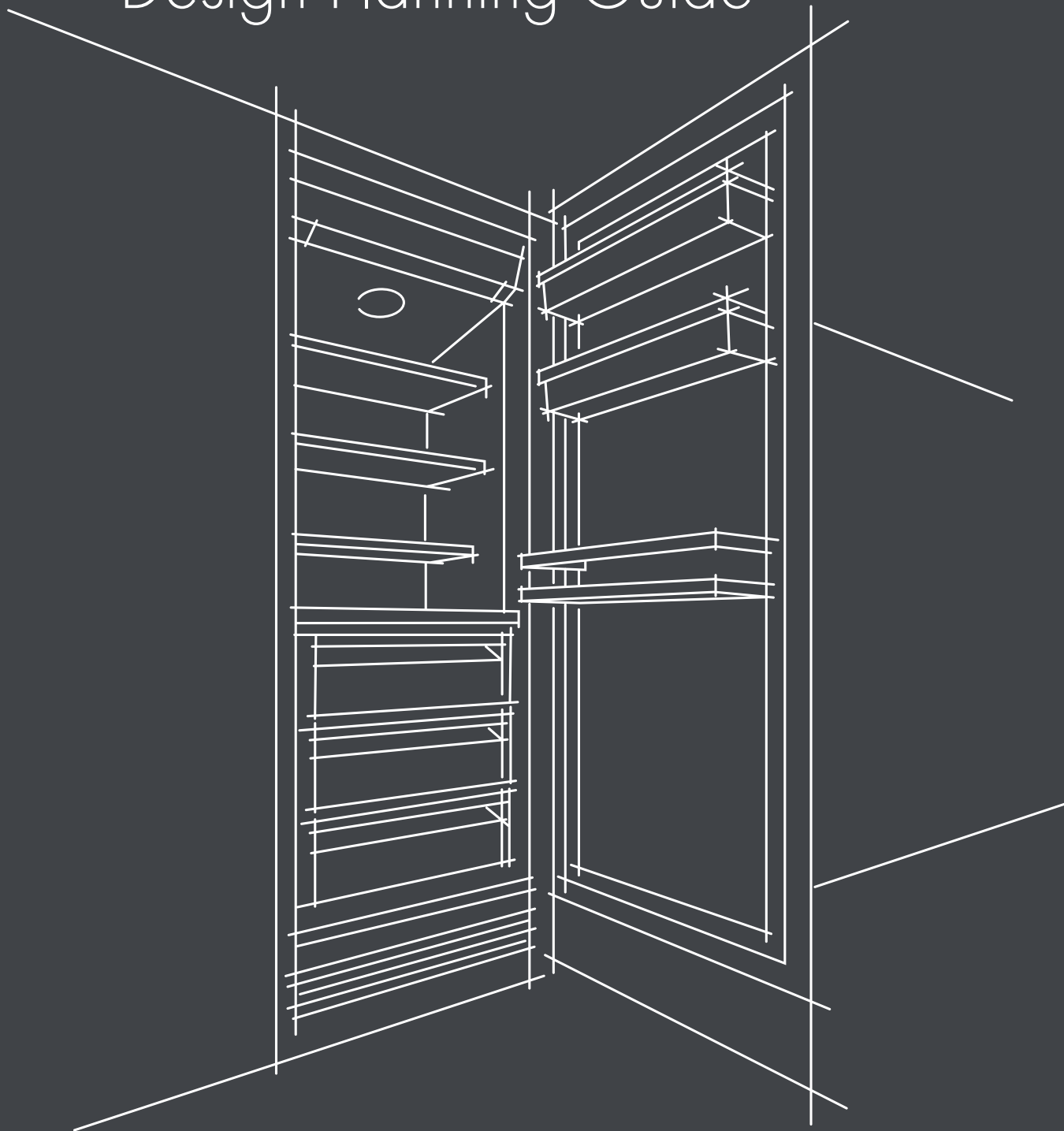

LIEBHERR

MONOLITH

Cooling Redefined

The Monolith stands for a new generation of fully integrated refrigerators, freezers, and wine cabinets. It is based on over 60 years of innovation and German engineering, setting new standards for food and wine storage.

Luxury features, impressive dimensions, modern components for maximum energy efficiency and innovative technologies such as PowerCooling and BioFresh for storing food and keeping it fresh for significantly longer are what make Monolith appliances so unique. Monolith columns can be combined in a variety of ways according to individual requirements and preferences.

Monolith: A whole new dimension of refrigerating and freezing.





Model overview

Model	Features	Door hinges ¹ on delivery	Front ² (* optional accessories)
Fridge			
 <p>EKB 9471</p> <p>◀76.2▶ 213.4</p>	<p>Bio Fresh-Plus</p> <p>Infinity Swipe Infinity Light Infinity Spring Soft System</p> <p>Soft Telescopic Super Cool Power Cooling</p>	 <p>¹right, reversible</p>	  <p>* stainless steel front customer spec. door front</p>
 <p>EKB 9671</p> <p>◀91.4▶ 213.4</p>	<p>Bio Fresh-Plus</p> <p>Infinity Swipe Infinity Light Infinity Spring Soft System</p> <p>Soft Telescopic Super Cool Power Cooling</p>	 <p>¹right, reversible</p>	  <p>* stainless steel front customer spec. door front</p>
Freezer			
 <p>EGN 9171</p> <p>◀45.7▶ 213.4</p>	<p>No Frost</p> <p>Infinity Swipe Infinity Light Ice Maker Soft System</p> <p>Soft Telescopic Super Frost Frost Safe System</p>	 <p>¹left, reversible</p>	  <p>* stainless steel front customer spec. door front</p>
 <p>EGN 9271</p> <p>◀61.0▶ 213.4</p>	<p>No Frost</p> <p>Infinity Swipe Infinity Light Ice Maker Soft System</p> <p>Soft Telescopic Super Frost Frost Safe System</p>	 <p>¹left, reversible</p>	  <p>* stainless steel front customer spec. door front</p>
Wine			
 <p>EWT 9275</p> <p>◀61.0▶ 213.4</p>	<p>Infinity Swipe Infinity Light Wine Soft System Telescopic Rails</p>	 <p>¹right, reversible</p>	  <p>* stainless steel front customer spec. door front</p>

Niches are in cm

¹ Door hinge exchange set on page 23 required for reversing hinges. Reversals to be performed by a Liebherr Authorised Dealer.

² Door front dimensions and weights on pages 25.

Side-by-Side combination

The Monolith series offers a range of options for your new dream kitchen, as a stand-alone unit or as a combination comprising two or more appliances. This creates numerous options for optimal food storage.

The Side-by-Side kit on page 23 is required if there is less than 102 mm spacing between appliances.

Please refer to page 27 for detailed information about the cut-out niche measurements.

Examples of possible combinations with two or three appliances

Niches are in cm

◀121.9▶	◀137.2▶	◀137.2▶
 <p>EGN 9171 Freezer</p> <p>EKB 9471 Fridge</p>	 <p>EGN 9171 Freezer</p> <p>EKB 9671 Fridge</p>	 <p>EGN 9271 Freezer</p> <p>EKB 9471 Fridge</p>
◀152.4▶	◀182.9▶	◀198.1▶
 <p>EGN 9271 Freezer</p> <p>EKB 9671 Fridge</p>	 <p>EGN 9171 Freezer</p> <p>EWT 9275 Wine Cabinet</p> <p>EKB 9471 Fridge</p>	 <p>EGN 9171 Freezer</p> <p>EWT 9275 Wine Cabinet</p> <p>EKB 9671 Fridge</p>
◀198.1▶	◀213.4▶	
 <p>EGN 9271 Freezer</p> <p>EWT 9275 Wine Cabinet</p> <p>EKB 9471 Fridge</p>	 <p>EGN 9271 Freezer</p> <p>EWT 9275 Wine Cabinet</p> <p>EKB 9671 Fridge</p>	



EKB 9471

REFRIGERATION



76.2cm Monolith refrigerator



◀76.2▶

EKB 9471



Energy consumption (kWh/y) Star rating	234 3.5
Sound rating dB(A) *	39
Total net capacity of fridge in litres	430
of which BioFresh net capacity in litres	188
Number of storage shelves, of which height-adjustable	4/3
Number of door racks	3
Number of BioFresh / BioFresh-Plus safes with LED lighting	2/1
Electronic control	InfinitySwipe
Refrigerator temperature range °C **	+2°C to +7°C
Defrosting method	Automatic
Interior lighting	InfinityLight
Integrated water dispenser / Fixed water connection 20 mm (3/4")	InfinitySpring
Water filter	Yes
Door hinge	Right, reversible ***
Product Dimensions	
in cm (H/W/D)	212.6/75.4/61
Cut Out Dimensions	
in cm (H/W/D)	213.4/76.2/min. 63.5
Gross / Net weight in kg	193 / 178
Voltage V / Connected load A / Frequency Hz	220-240 / 1.5 / 50
Warranty	5 Years

* Noise output - according to EN 60704-3.

** BioFresh bins, 0°C. BioFresh-Plus bins, -2°C or 0°C.

*** Please contact your Liebherr Authorised Dealer for door reversal.

Optional accessories

- Flat brushed aluminium handle
- Square brushed aluminium handle
- Round stainless steel handle
- Stainless steel front
- Toe kick made of stainless steel
- Side-by-Side kit
- Door hinge exchange set

Optional accessories on pages 22-23.

Product Dimensions

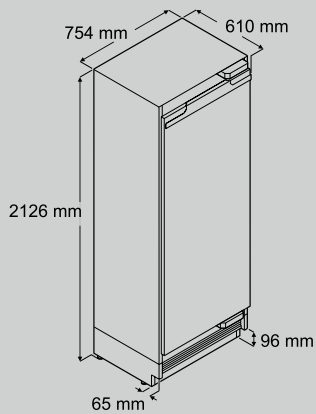

IMPORTANT!

Stated minimum height dimensions include height of the adjustable feet when fully inserted.

Height can be increased by a maximum of 19 mm by turning the adjustable feet. When the appliance is fitted in the recess, the appliance must be raised by turning the adjustable feet so that the appliance top has contact with the anti-tipping bracket. This results in a 102 mm toe kick height.

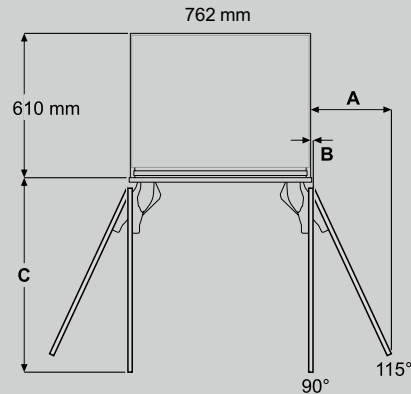

Internal door panel

A = 337 mm
B = 12.5 mm
C = 810 mm

External door panel

A = 343 mm
B = 12.5 mm
C = 822 mm

Dimension A = without fitted door handle

Cut Out Dimensions

Individual toe kick

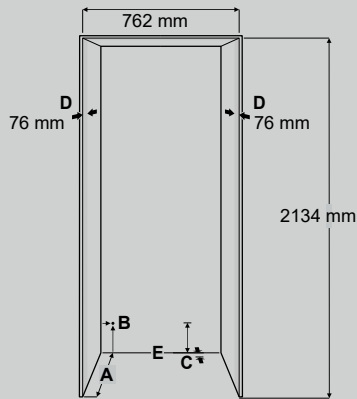

Continuous toe kick

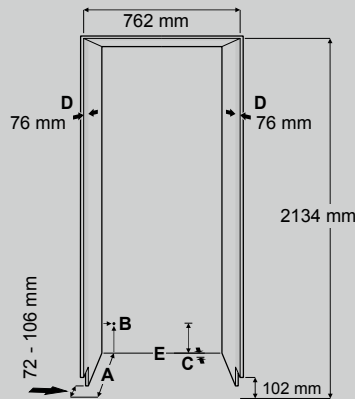

A

Unit depth
with external door panel installation: 635 mm
with internal door panel installation: 635 mm + thickness of custom panel.

B

Point at which the mains cable exits from the rear of the appliance (19 mm from the left and 127 mm from the floor). The free length of the mains cable is 2.5 m.

C

The appliance has a recess in this area for cable and water line routing: Depth is 25 mm, and height 140 mm across the entire appliance width.

D

This surface is visible when the appliance door is opened. Designed finish is therefore recommended.

E

The anti-tipping device positioned at the base of the appliance must be secured to the floor or to the wall.

Door Front Dimensions

and dimensions of free length for power / water

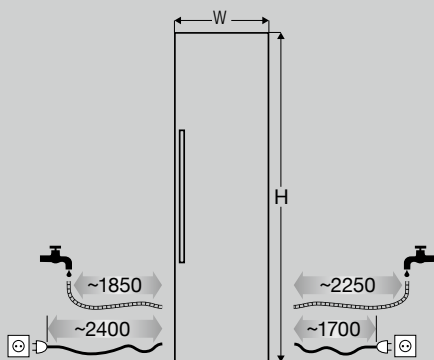

Integrated installation

H = 2029 mm
W = 756 mm

Frameless installation

H = 2032 mm
(plus the dimensions of overlapping of the panel on the top)
W = 762 mm
(plus the dimensions of overlapping of the panel on both sides)

Thickness of the front: min. 16 mm* / max. 30 mm
Weight of front and handle: max. 35 kg

Installations behind the appliance are not possible.

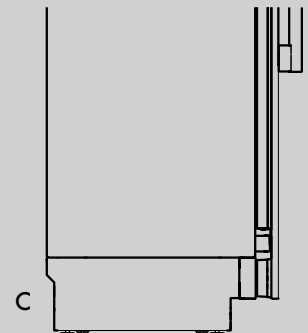

* If a five-piece shaker style front is used, which is thinner than the minimum front thickness, shorter screws than those supplied in the accessory pack must be used.

For further relevant planning and safety requirements see pages 24-31.

91.4cm Monolith refrigerator



◀91.4▶

EKB 9671



Energy consumption (kWh/y) Star rating	263 3.5
Sound rating dB(A) *	39
Total net capacity of fridge in litres	534
of which BioFresh net capacity in litres	235
Number of storage shelves, of which height-adjustable	4/3
Number of door racks	3
Number of BioFresh / BioFresh-Plus safes with LED lighting	2/1
Electronic control	InfinitySwipe
Refrigerator temperature range °C **	+2°C to +7°C
Defrosting method	Automatic
Interior lighting	InfinityLight
Integrated water dispenser / Fixed water connection 20 mm (3/4")	InfinitySpring
Water filter	Yes
Door hinge	Right, reversible ***
Product Dimensions	
in cm (H/W/D)	212.6/90.9/61
Cut Out Dimensions	
in cm (H/W/D)	213.4/91.4/min. 63.5
Gross / Net weight in kg	214 / 199
Voltage V / Connected load A / Frequency Hz	220-240 / 1.5 / 50
Warranty	5 Years

* Noise output - according to EN 60704-3.

** BioFresh bins, 0°C. BioFresh-Plus bins, -2°C or 0°C.

*** Please contact your Liebherr Authorised Dealer for door reversal.

Optional accessories

- Flat brushed aluminium handle
- Square brushed aluminium handle
- Round stainless steel handle
- Stainless steel front
- Toe kick made of stainless steel
- Side-by-Side kit
- Door hinge exchange set

Optional accessories on pages 22-23.

Product Dimensions

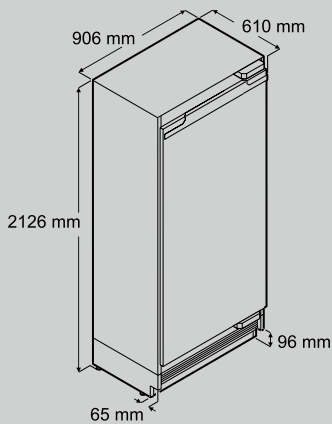

IMPORTANT!

Stated minimum height dimensions include height of the adjustable feet when fully inserted.

Height can be increased by a maximum of 19 mm by turning the adjustable feet. When the appliance is fitted in the recess, the appliance must be raised by turning the adjustable feet so that the appliance top has contact with the anti-tipping bracket. This results in a 102 mm toe kick height.

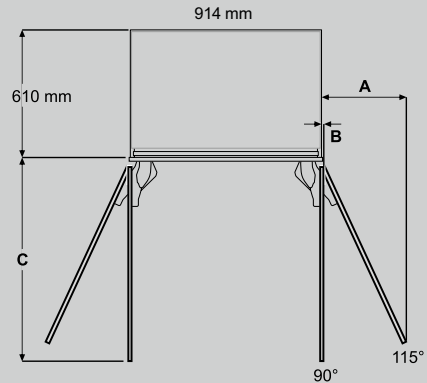

Internal door panel

A = 400 mm
B = 12.5 mm
C = 962 mm

External door panel

A = 406 mm
B = 12.5 mm
C = 975 mm

Dimension A = without fitted door handle

Cut Out Dimensions

Individual toe kick

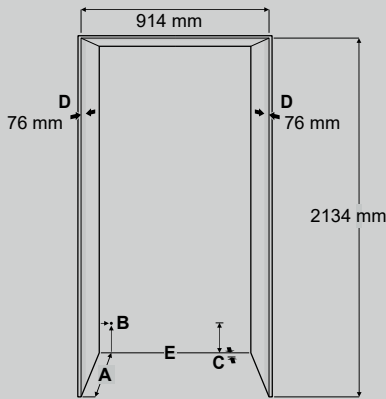

Continuous toe kick

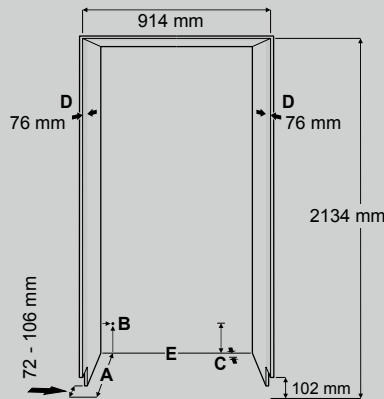

A

Unit depth
with external door panel installation: 635 mm
with internal door panel installation: 635 mm + thickness of custom panel.

B

Point at which the mains cable exits from the rear of the appliance (19 mm from the left and 127 mm from the floor). The free length of the mains cable is 2.5 m.

C

The appliance has a recess in this area for cable and water line routing: Depth is 25 mm, and height 140 mm across the entire appliance width.

D

This surface is visible when the appliance door is opened. Designed finish is therefore recommended.

E

The anti-tipping device positioned at the base of the appliance must be secured to the floor or to the wall.

Door Front Dimensions

and dimensions of free length for power / water

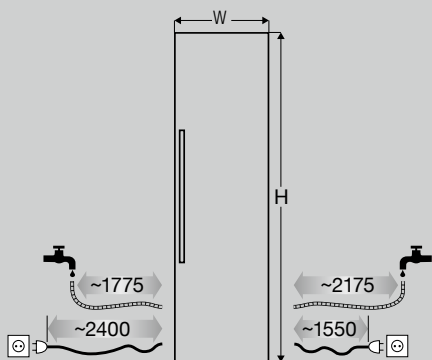

Integrated installation

H = 2029 mm
W = 908 mm

Frameless installation

H = 2032 mm
(plus the dimensions of overlapping of the panel on the top)
W = 914 mm
(plus the dimensions of overlapping of the panel on both sides)

Thickness of the front: min. 16 mm* / max. 30 mm
Weight of front and handle: max. 40 kg

Installations behind the appliance are not possible.

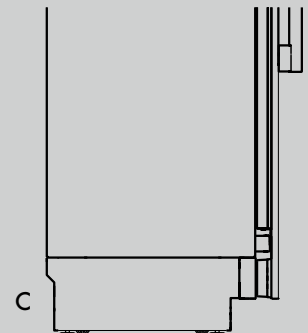

* If a five-piece shaker style front is used, which is thinner than the minimum front thickness, shorter screws than those supplied in the accessory pack must be used.

For further relevant planning and safety requirements see pages 24-31.



EGN 9171

FREEZING



45.7cm Monolith freezer



◀45.7▶

EGN 9171

No Frost	Infinity Swipe	Infinity Light	Ice Maker	Soft System	Soft Telescopic
----------	----------------	----------------	-----------	-------------	-----------------

Energy consumption (kWh/y) Star rating	355 3.0
Sound rating dB(A) *	39
Net capacity of freezer in litres	218
Number of storage shelves, of which height-adjustable	4/3
Number of door racks	3
Number of FrostSafe drawers	3
Electronic control	InfinitySwipe
Temperature range of freezer °C	-14°C to -27°C
Defrosting method	Automatic
Interior lighting	InfinityLight
IceMaker	Fixed water connection 20 mm (3/4")
Water filter	Yes
Ice cube production in 24 h/kg	1.6
Ice cube storage capacity in kg	1.8
Storage time in event of a fault in hours	14
Freezing capacity in 24 h/kg	12
Door hinge	Left, reversible **
Product Dimensions	
in cm (H/W/D)	212.6/45/61
Cut Out Dimensions	
in cm (H/W/D)	13.4/45.7/min. 63.5
Gross / Net weight in kg	152 / 137
Voltage V / Connected load A / Frequency Hz	220-240 / 2.0 / 50
Warranty	5 Years

* Noise output - according to EN 60704-3.

** Please contact your Liebherr Authorised Dealer for door reversal.

Optional accessories

- Flat brushed aluminium handle
- Square brushed aluminium handle
- Round stainless steel handle
- Stainless steel front
- Toe kick made of stainless steel
- Side-by-Side kit
- Door hinge exchange set

Optional accessories on pages 22-23.

Product Dimensions

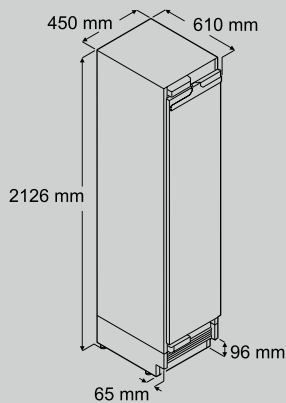

IMPORTANT!

Stated minimum height dimensions include height of the adjustable feet when fully inserted.

Height can be increased by a maximum of 19 mm by turning the adjustable feet. When the appliance is fitted in the recess, the appliance must be raised by turning the adjustable feet so that the appliance top has contact with the anti-tipping bracket. This results in a 102 mm toe kick height.

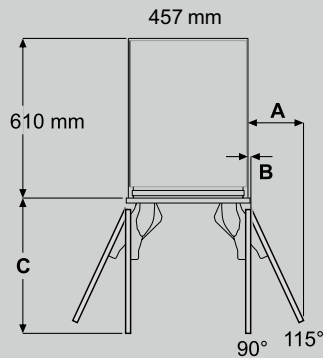

Internal door panel

A = 210 mm
B = 12.5 mm
C = 505 mm

External door panel

A = 216 mm
B = 12.5 mm
C = 517 mm

Dimension A = without fitted door handle

Cut Out Dimensions

Individual toe kick



Continuous toe kick

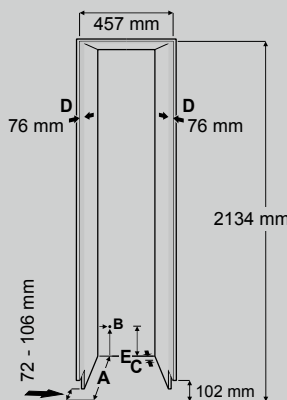

A

Unit depth
with external door panel installation: 635 mm
with internal door panel installation: 635 mm + thickness of custom panel.

B

Point at which the mains cable exits from the rear of the appliance (19 mm from the left and 127 mm from the floor). The free length of the mains cable is 2.5 m.

C

The appliance has a recess in this area for cable and water line routing: Depth is 25 mm, and height 140 mm across the entire appliance width.

D

This surface is visible when the appliance door is opened. Designed finish is therefore recommended.

E

The anti-tipping device positioned at the base of the appliance must be secured to the floor or to the wall.

Door Front Dimensions

and dimensions of free length for power / water

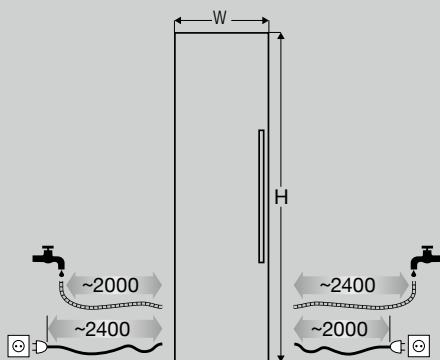

Integrated installation

H = 2029 mm
W = 451 mm

Frameless installation

H = 2032 mm
(plus the dimensions of overlapping of the panel on the top)
W = 457 mm
(plus the dimensions of overlapping of the panel on both sides)

Thickness of the front: min. 16 mm* / max. 30 mm
Weight of front and handle: max. 25 kg

Installations behind the appliance are not possible.

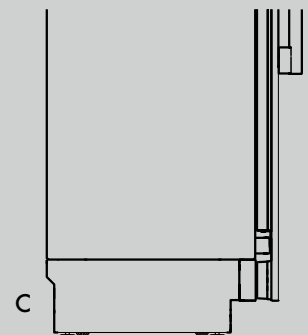

* If a five-piece shaker style front is used, which is thinner than the minimum front thickness, shorter screws than those supplied in the accessory pack must be used.

For further relevant planning and safety requirements see pages 24–31.

61.0cm Monolith freezer



◀61.0▶

EGN 9271

No Frost	Infinity Swipe	Infinity Light	Ice Maker	Soft System	Soft Telescopic
----------	----------------	----------------	-----------	-------------	-----------------

Energy consumption (kWh/y) Star rating	399 3.0
Sound rating dB(A) *	39
Net capacity of freezer in litres	322
Number of storage shelves, of which height-adjustable	4/3
Number of door racks	3
Number of FrostSafe drawers	3
Electronic control	InfinitySwipe
Temperature range of freezer °C	-14°C to -27°C
Defrosting method	Automatic
Interior lighting	InfinityLight
IceMaker	Fixed water connection 20 mm (3/4")
Water filter	Yes
Ice cube production in 24 h/kg	1.6
Ice cube storage capacity in kg	2.4
Storage time in event of a fault in hours	19
Freezing capacity in 24 h/kg	12
Door hinge	Left, reversible **
Product Dimensions	
in cm (H/W/D)	212.6/60.2/61
Cut Out Dimensions	
in cm (H/W/D)	213.4/61 / min. 63.5
Gross / Net weight in kg	170 / 157
Voltage V / Connected load A / Frequency Hz	220-240 / 2.0 / 50
Warranty	5 Years

* Noise output - according to EN 60704-3.

** Please contact your Liebherr Authorised Dealer for door reversal.

Optional accessories

- Flat brushed aluminium handle
- Square brushed aluminium handle
- Round stainless steel handle
- Stainless steel front
- Toe kick made of stainless steel
- Side-by-Side kit
- Door hinge exchange set

Optional accessories on pages 22-23.

Product Dimensions

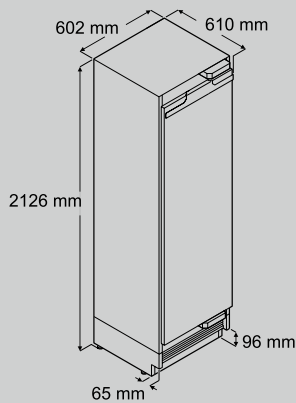

IMPORTANT!

Stated minimum height dimensions include height of the adjustable feet when fully inserted.

Height can be increased by a maximum of 19 mm by turning the adjustable feet. When the appliance is fitted in the recess, the appliance must be raised by turning the adjustable feet so that the appliance top has contact with the anti-tipping bracket. This results in a 102 mm toe kick height.

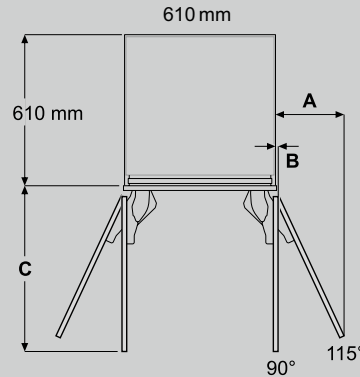

Internal door panel

A = 273 mm
B = 12.5 mm
C = 658 mm

External door panel

A = 279 mm
B = 12.5 mm
C = 670 mm

Dimension A = without fitted door handle

Cut Out Dimensions

Individual toe kick

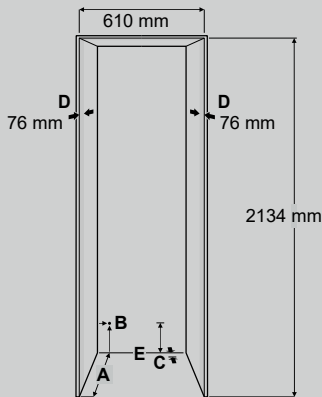

Continuous toe kick

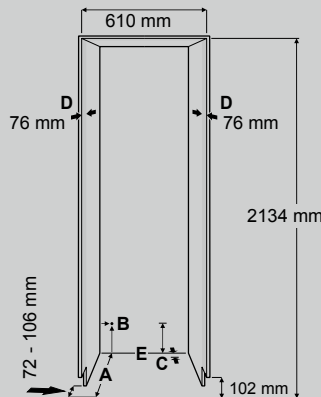

A

Unit depth
with external door panel installation: 635 mm
with internal door panel installation: 635 mm + thickness of custom panel.

B

Point at which the mains cable exits from the rear of the appliance (19 mm from the left and 127 mm from the floor). The free length of the mains cable is 2.5 m.

C

The appliance has a recess in this area for cable and water line routing: Depth is 25 mm, and height 140 mm across the entire appliance width.

D

This surface is visible when the appliance door is opened. Designed finish is therefore recommended.

E

The anti-tipping device positioned at the base of the appliance must be secured to the floor or to the wall.

Door Front Dimensions

and dimensions of free length for power / water

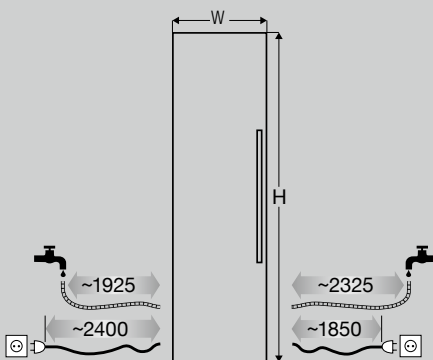

Integrated installation

H = 2029 mm
W = 603 mm

Frameless installation

H = 2032 mm
(plus the dimensions of overlapping of the panel on the top)
W = 610 mm
(plus the dimensions of overlapping of the panel on both sides)

Thickness of the front: min. 16 mm* / max. 30 mm
Weight of front and handle: max. 30 kg

Installations behind the appliance are not possible.

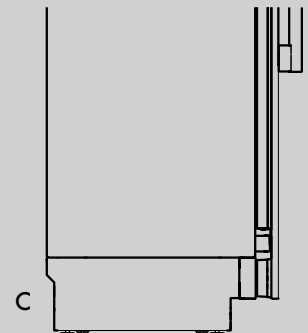

* If a five-piece shaker style front is used, which is thinner than the minimum front thickness, shorter screws than those supplied in the accessory pack must be used.

For further relevant planning and safety requirements see pages 24-31.



EWT 9275

WINE



61.0cm Monolith wine



◀61.0▶

Optional accessories

- Flat brushed aluminium handle
- Square brushed aluminium handle
- Round stainless steel handle
- Stainless steel front
- Toe kick made of stainless steel
- Side-by-Side kit
- Door hinge exchange set

Optional accessories on pages 22-23.

EWT 9275

Infinity Swipe	Infinity Light	Wine	Soft System	Soft Telescopic
----------------	----------------	------	-------------	-----------------

Sound rating dB(A) *	42
Net capacity in litres	320
Max. No. of Bordeaux bottles (0.75 litre)	100
Energy consumption in 365 days/24 h°	155
Number of storage shelves	9
Running on telescopic rails	9
InfinityBoard	Yes
Shelf material	Aluminium & beech
Electronic control	InfinitySwipe
Temperature range °C	+5°C to +20°C
Temperature zones	3
Temperature alarm	Visual and audible
Interior lighting	InfinityLight
Door alarm	Audible
Safety thermostat	Yes
FreshAir activated charcoal filter	Yes
Door type	Insulated glass door
Door hinge	Right, reversible **
Product Dimensions	
in cm (H/W/D)	212.6 / 60.2 / 61
Cut Out Dimensions	
in cm (H/W/D)	213.4/61/min. 63.5
Gross / Net weight in kg	174 / 162
Voltage V / Connected load A / Frequency Hz	220-240 / 1.5 / 50
Warranty	5 Years

* Noise output - according to EN 60704-3.

** Please contact your Liebherr Authorised Dealer for door reversal.

° Measurements taken at +25°C ambient and +12°C interior temperature tested by Liebherr Germany (not to Australian standards).

Product Dimensions

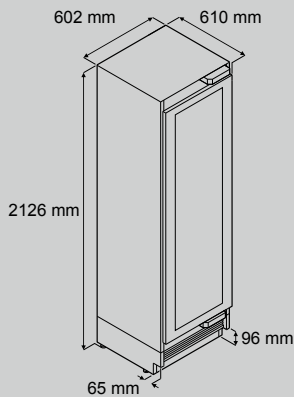

IMPORTANT!

Stated minimum height dimensions include height of the adjustable feet when fully inserted.

Height can be increased by a maximum of 19 mm by turning the adjustable feet. When the appliance is fitted in the recess, the appliance must be raised by turning the adjustable feet so that the appliance top has contact with the anti-tipping bracket. This results in a 102 mm toe kick height.

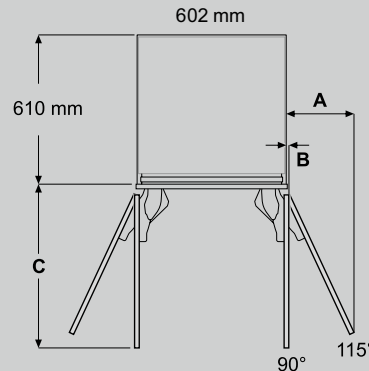

Internal door panel

A = 273 mm
B = 12.5 mm
C = 658 mm

External door panel

A = 279 mm
B = 12.5 mm
C = 670 mm

Dimension A = without mounted door handle

Cut Out Dimensions

Individual toe kick

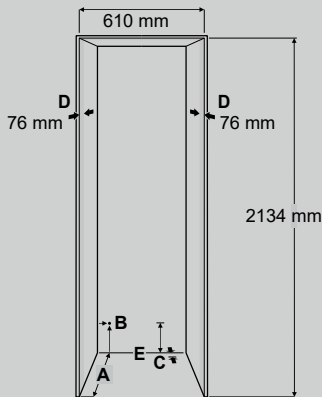

Continuous toe kick

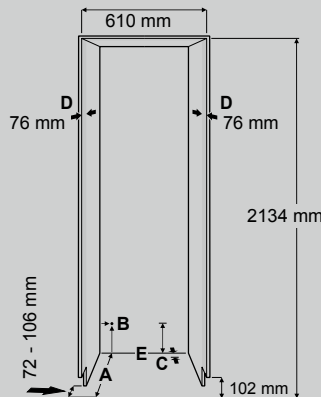

A

Unit depth
with external door panel installation: 635 mm
with internal door panel installation: 635 mm + thickness of custom panel.

B

Point at which the mains cable exits from the rear of the appliance (19 mm from the left and 127 mm from the floor). The free length of the mains cable is 2.5 m.

C

The appliance has a recess in this area for cable and water line routing: Depth is 25 mm, and height 140 mm across the entire appliance width.

D

This surface is visible when the appliance door is opened. Designed finish is therefore recommended.

E

The anti-tipping device positioned at the base of the appliance must be secured to the floor or to the wall.

Door Front Dimensions

and dimensions of free length for power

Integrated installation

H = 2029 mm / h = 1495 mm
W = 603 mm / w = 432 mm

Framless installation

H = 2032 mm
(plus the dimensions of overlapping of the panel on the top)
W = 610 mm
(plus the dimensions of overlapping of the panel on both sides)

Thickness of the front: min. 16 mm* / max. 30 mm
Weight of front: max. 24 kg

Installations behind the appliance are not possible.

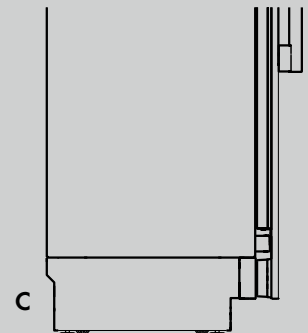
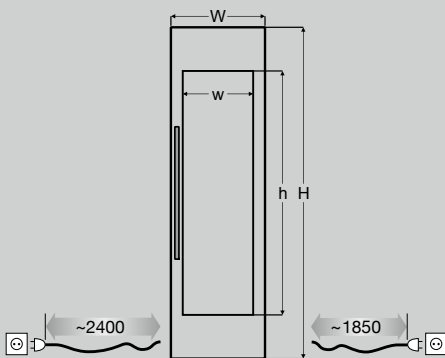

* If a five-piece shaker style front is used, which is thinner than the minimum front thickness, shorter screws than those supplied in the accessory pack must be used.

For further relevant planning and safety requirements see pages 24–31.

Optional accessories

Stainless steel fronts

The holes for fitting the handle have been drilled centrally with a spacing of 770 mm in order that the stainless steel panel can be turned by 180° in the event that a door hinge is changed.

Stainless steel fronts (for refrigerators & freezers)

45.7 cm (dimensions: 2029 mm x 451 mm x 19 mm, weight: 18.4 kg)	39901916
61.0 cm (dimensions: 2029 mm x 603 mm x 19 mm, weight: 24 kg)	39901883
76.2 cm (dimensions: 2029 mm x 756 mm x 19 mm, weight: 28 kg)	39901872
91.4 cm (dimensions: 2029 mm x 908 mm x 19 mm, weight: 32 kg)	39901458

Stainless steel fronts (for wine cabinets)

61.0 cm (dimensions: 2029 mm x 603 mm x 19 mm, weight: 11.3 kg)	39901533
--	----------

Stainless steel fronts (for refrigerators & freezers)

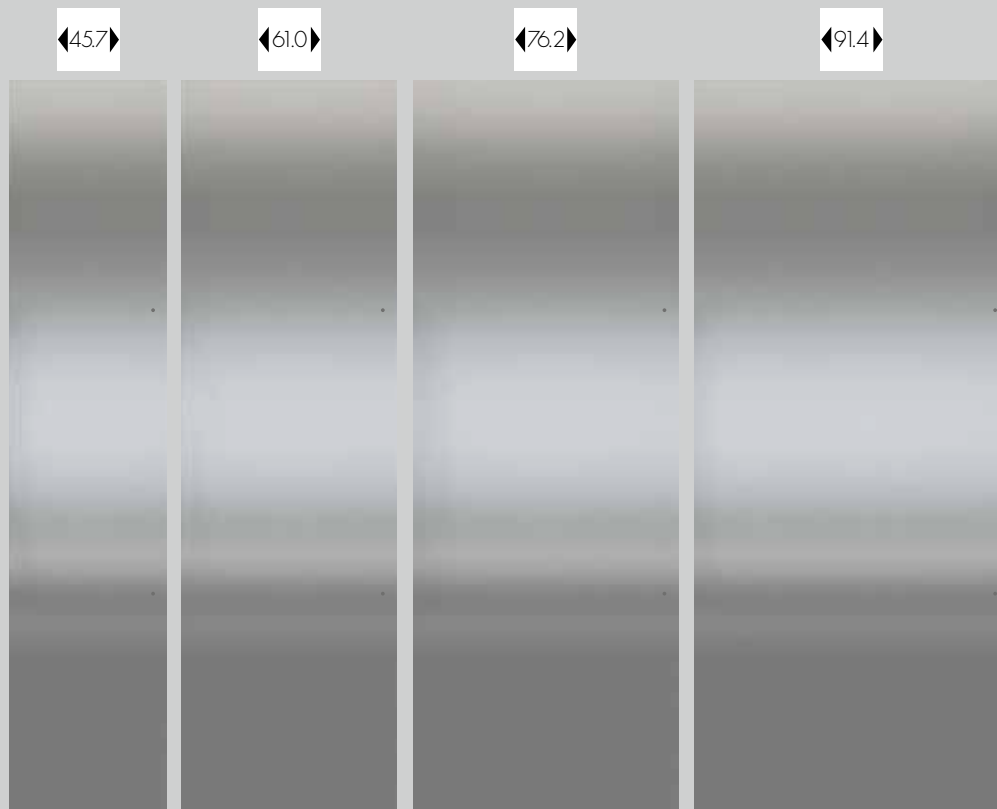

Stainless steel fronts (for wine cabinets)

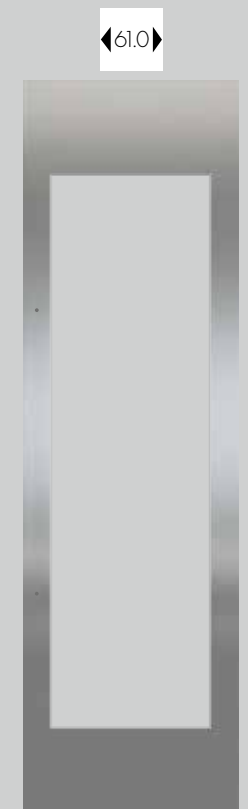

Handles

Fastening screws are included in the scope of delivery. The spacing between the two screw holes is 770 mm and the handle length is 810 mm.

1	Flat brushed aluminium handle (depth: 48 mm, weight: 0.8 kg)	39901461
2	Square brushed aluminium handle (depth: 55 mm, weight: 1.2 kg)	39901492
3	Round stainless steel handle (depth: 62 mm, weight: 2.3 kg)	39901489



Stainless steel toe kicks

Toe kicks are 102 mm high.

45.7 cm	39901493	121.9 cm	39901765
61.0 cm	39901496	137.1 cm	39901787
76.2 cm	39901530	152.4 cm	39902366
91.4 cm	39902349	167.6 cm	39902819
106.7 cm	39901552	182.8 cm	39902390



Side-by-Side kit

A Side-by-Side kit is required if there is less than 102 mm spacing between appliances. The set includes side wall heating to prevent condensation between appliances as well as metal brackets and screws for connecting the appliances. The set needs to be fitted to the right hand side of the appliance to its left. Decorative trim is also included for covering the gap (approx. 6-8 mm) between the two appliances when installed. No additional mains connection is required for the side wall heating, a slot is provided for this on the rear of the appliance. Use of Side-by-Side kit increases the energy consumption by 0.4 kWh/24hrs for two appliances and 0.8 kWh/24hrs for three appliances.

Can be used with all Monolith model combinations 39901428



Door hinge exchange set

To be used when reversing factory-fitted hinges
To be performed by a Liebherr authorised engineer 39902399

Planning information

Installation space requirements

The space in which the appliance is to be installed must meet the following requirements:

- The floor must be capable of bearing the weight of the appliance plus - depending on the net capacity of the model - approx. min. 218 kg to max. 544 kg of food.
- The floor should be level. The fridge must be supported or levelled at floor level to ensure that the ventilation openings are clear.
- The cut out dimensions in the installation location have been correctly measured.
- The power socket is located in the correct position.

In order to transport the Monolith to the installation location, the door heights must also be considered on the route taken for transportation with the appliance packed and tilted.

Model	Max. ht (mm)
EGN 9171, EGN 9271	2396
EKB 9471, EWT 9275	2414
EKB 9671	2469

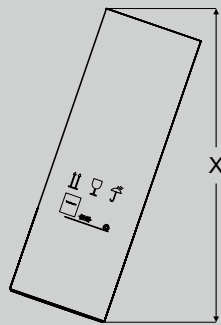

The appliance should only be installed next to Liebherr fridges and freezers. The Liebherr models are designed to be set up Side-by-Side. A Side-by-Side kit is necessary for this (for separate accessories, see page 23). If a Monolith appliance is installed next to another fridge or freezer, this may result in condensation or damage the Liebherr appliance.

Cut out requirements

When planning the recess and the safe installation it is important to make sure that the top and carcass walls line up flush with the appliance at a depth of at least 102 mm from the outside edge and are comprised of appropriately thick material (at least 16 mm).

Because the unit recess is partially visible when the appliance door is opened, it should be ensured that the inside matches the unit surface at the top and at the side and also has a minimum depth of 102 mm.

The scope of supply of the Monolith appliances includes a decorative trim for covering the gap between the appliance and side walls of the fitted unit.

Monolith appliances are designed for flush installation in units with a depth of 635 mm with stainless steel fronts or customer-specific panels, according to the design of the kitchen, available as an accessory.

Wooden fronts generally have a thickness of 19 mm, however thicker fronts and other materials may also be used. Because the carcass sides are visible, designed carcass finishes from the kitchen manufacturer are recommended.

In the case of customer-specific models, it must also be ensured that, for the door hinge, the maximum permitted front weight of the respective model is not exceeded.

IMPORTANT

In order to prevent potential damage to the fridge, the appliance should be left to stand for one hour in the installation location before switching on in order that the fluids in the coolant and lubrication system can distribute evenly.

Door front dimensions and weights

Model	H Internal door panel installation	W Internal door panel installation	H External door panel installation	W External door panel installation	Max. front weight
EKB 9471	2029 mm	756 mm	2032 mm ¹	762 mm ²	35 kg
EKB 9671	2029 mm	908 mm	2032 mm ¹	914 mm ²	40 kg
EGN 9171	2029 mm	451 mm	2032 mm ¹	457 mm ²	25 kg
EGN 9271	2029 mm	603 mm	2032 mm ¹	610 mm ²	30 kg
EWT 9275	2029 mm	603 mm	2032 mm ¹	610 mm ²	24 kg

¹ Overlap of the front at the top not taken into account.

² Overlap of the front on right and left not taken into account.

The depth of the Monolith appliances is 610 mm which means that they may be installed without difficulty in a fitted unit of standard European depth (610 mm) but also in deeper cut-outs of 635 mm in order to provide flexible installation options.

In the case of flush installation, the door front dimensions for installation with an internal door panel must be used.

For all other installation options, the door spacing requirements must be observed (page 29) in order to determine the door front dimensions.

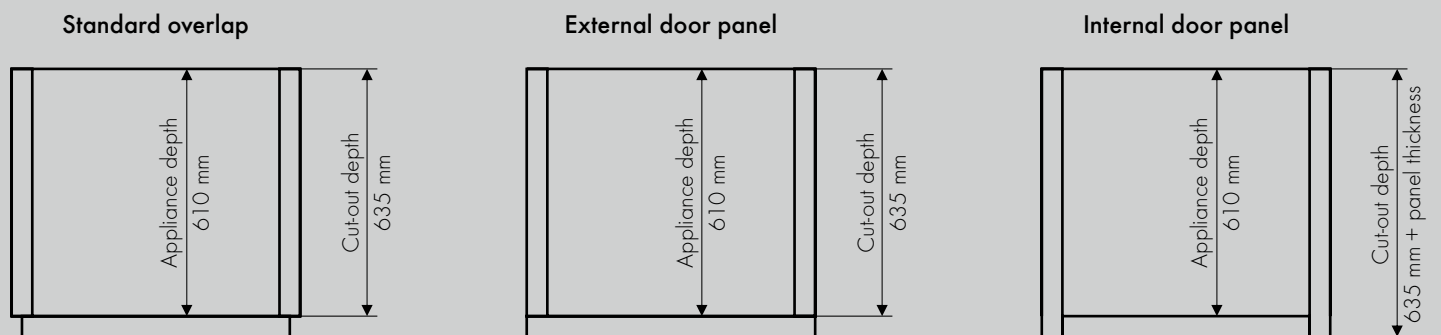

Installation recommendation

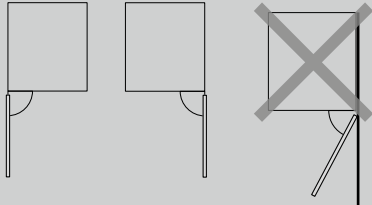
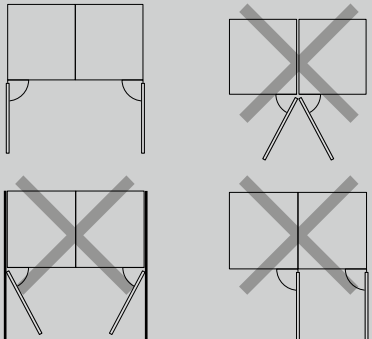
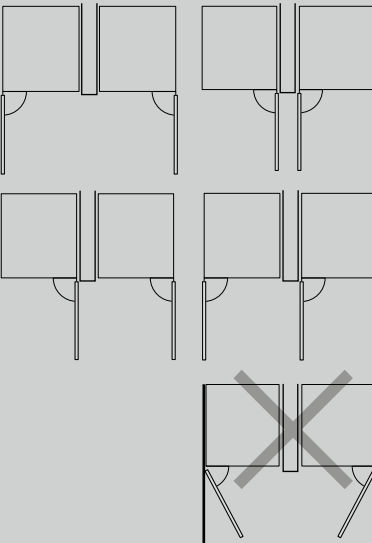
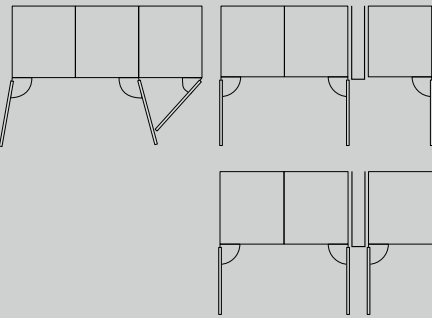
<p>Individual positioning</p>		<p>All Monolith appliances can be installed as stand-alone appliances with the hinge on the left or the right. When sizing the fitted unit take into account the thickness of the door panel and the handle.</p> <p>In order to prevent the appliance door including the handle from colliding with adjoining walls or elements of the kitchen, a minimum spacing of 76 mm must be included for a door opening limited to 90°.</p> <p>See also "Door spacing requirements" on page 29.</p>
<p>Side-by-Side in a fitted unit</p>		<p>Monolith appliances may be installed Side-by-Side in a fitted unit. For this, a Side-by-Side kit which is separately available is required if the spacing between the installed appliances is less than 102 mm. When sizing the fitted unit take into account the thickness of the door panel and the handle.</p> <p>In order to prevent the appliance doors including the handles from colliding with adjoining walls or elements of the kitchen, a minimum spacing of 76 mm must be included for a door opening limited to 90°.</p> <p>See also "Door spacing requirements" on page 29.</p>
<p>Side-by-Side in separate units</p>		<p>Monolith appliances may be installed Side-by-Side in different units. If the dividing wall between the units has a thickness of less than 102 mm, a separately available Side-by-Side kit is required.</p> <p>In order to prevent the appliance doors including the handles from colliding with adjoining walls or elements of the kitchen, a minimum spacing of 76 mm must be included for a door opening limited to 90°.</p> <p>In the case of back-to-back door positioning (as shown in adjacent drawing, top right) a minimum spacing of 154 mm must be included.</p> <p>See also "Door spacing requirements" on page 29.</p>
<p>Triple Side-by-Side</p>		<p>When combining more than two Monoliths together there are different installation options:</p> <p>A: Three units can be installed using two Side-by-Side kits. Note there will be door interference with this set up. When using stainless steel panel, this will offer a true Side-by-Side integrated look.</p> <p>B: A panel with a minimum thickness of 16 mm can be used between the third appliance and the kitted together pair. For this option two Side-by-Side kits are required. Note there will be door interference with this set up.</p> <p>C: A minimum partition of 102 mm width is required to ensure that handles do not collide when doors are opened in the same direction or 154 mm width is required to ensure that handles do not collide when doors are opened centered towards each other.</p> <p>See also "Door spacing requirements" on page 29.</p>

Side-by-Side installation

In order to determine the cut-out width for the Side-by-Side combinations, add together the individual widths of the appliances used in the combination. Below are the cut-out niches of combining two or three appliances. Width of four or more appliances are available upon request. The Side-by-Side kit on page 23 is required if there is less than 102 mm spacing between appliances.

individual

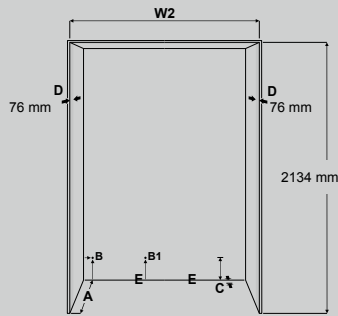

W1 (mm)	W2 (mm)	W3 (mm)
457	914	1372
610	1067	1524
762	1219	1676
914	1372	1829
	1524	1982
	1676	2134
	1829	2286
		2438
		2591
		2743

continuous

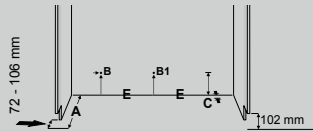

individual

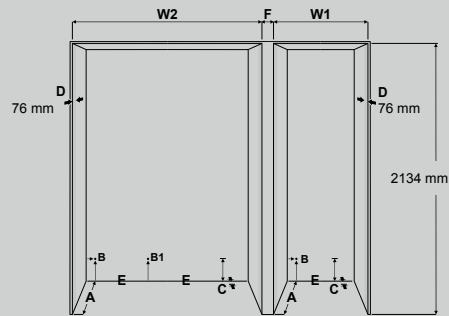
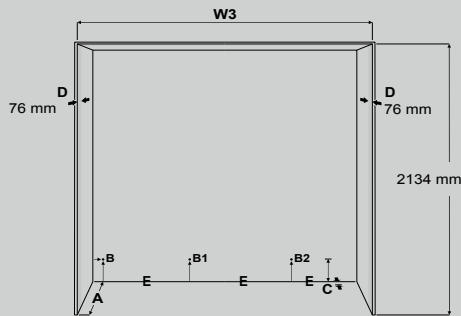

continuous

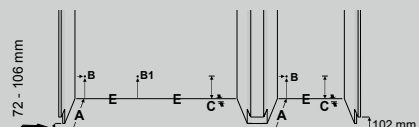
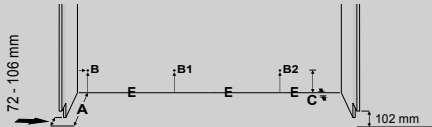

- A** Unit depth for overlay installation: 635 mm; for inset installation: 635 mm + thickness of the custom panel.
- B** Mains cable exit on rear of the device (19 mm from the left side and 127 mm from the floor). Free length of the mains cable: 2.5 m.
- B1, B2** Please refer to descriptions of the individual appliances for the precise position of these points for the combination.
- C** The appliance has a recess in this area for cable and water line routing: Depth is 25 mm, and height 140 mm across the entire appliance width.
- D** This surface is visible when the appliance door is opened. Designed finish is therefore recommended.
- E** The anti-tipping device positioned at the base of the appliance must be secured to the floor or to the wall.
- F** A minimum partition of 16 mm width is required when the installation type with a separate recess for additional appliance is applied. Note, there will be door interference with this set up. A minimum partition of 102 mm width is required to ensure that handles do not collide when doors are opened in the same direction. A minimum partition of 154 mm width is required to ensure that handles do not collide when doors are opened centered towards each other and 90° door opening stop (included in scope of supply) is applied at the same time.

W1, W2, W3 Width of one, two or three appliances.
Width of four or more appliances are available upon request.

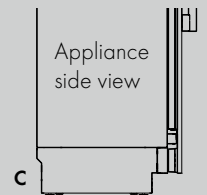

Ventilation requirements

Monolith appliances are ventilated entirely via the toe kick. The door fronts must close at least 102 mm above the floor. The grille in the toe kick must not be obstructed.

In the scope of supply of the Monolith appliances, spacers are included which must be fitted to the appliance and to the door in order to separate the warm outgoing air from the fresh air flowing in.

Liebherr provides a 102 mm high toe kick made of stainless steel as an optional accessory. This is available in the relevant width of the Monolith model and in possible Side-by-Side combinations (from 45.7 cm to 182.8 cm).

The toe kick, the position depth of which can be varied, is assembled by means of an adhesive joint (pre-assembled on the appliance).

See optional accessories on page 23.



Door spacing requirements

It is essential that Monolith appliances are set up or installed such that the doors (including handles) do not bump into adjoining cupboards, work surfaces, walls or other kitchen elements when they are opened.

If the door bumps into the wall or other units, a 90° door limiter can be installed (included in scope of supply).

Other possible solutions:

- Reduction in the thickness of the door front if this is greater than 19 mm.
- Repositioning of the element that collides with the appliance.
- Use of a stopper in order to prevent the door damaging the adjoining wall or the adjoining unit.

Internal door panel installation

View from above

Illustrated panel thickness: 30 mm

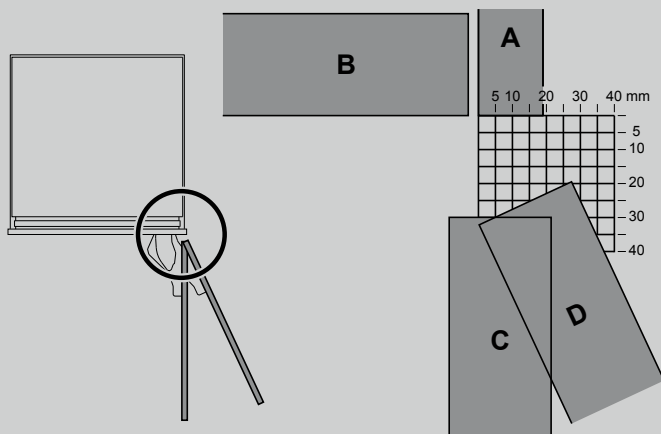

A = 19 mm unit carcass

B = Door front - door closed

C = Door front with door opened 90°

D = Door front with maximum door opening angle of 115°

External door panel installation

View from above

Illustrated panel thickness: 30 mm

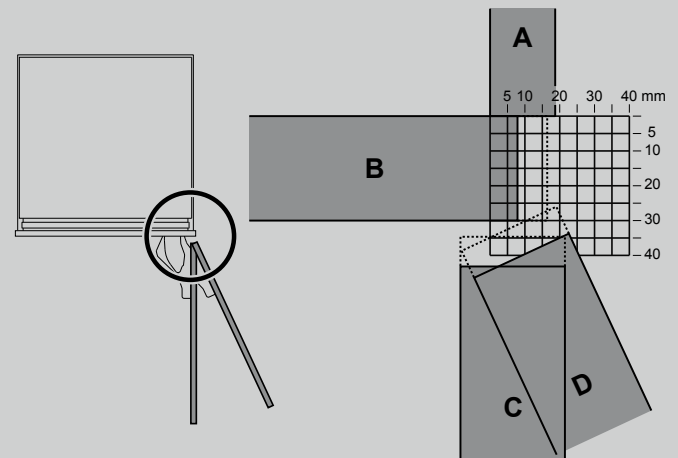

A = 19 mm unit carcass

B = Door front - door closed. Overlap on the front frame of the unit carcass is 8 mm. The dashed line shows an overlap of 17 mm over the front frame. This overlap only applies if the appliance is at the end of the kitchen units.

C = Door front with door opened 90°

D = Door front with maximum door opening angle of 115°

IMPORTANT

The minimum permitted size of the gap between the panels is 3 mm.

Safety requirements

Ambient temperatures

- The appliances are intended for refrigerating, freezing and storing food and for making ice (if equipped accordingly).
- All refrigerators and freezers are in climate class SN-T where as the wine cabinets are in climate class SN-ST.
- The refrigerant circuits have been checked for tightness.
- The appliances meet the applicable safety regulations.

Secure mounting

In order to prevent the appliance from tipping over following installation, the anti-tipping device must be fitted. Please note in this regard the information in the chapter "Mounting the anti-tipping device" in the installation instruction.

InfinitySpring (integrated water dispenser) and IceMaker (depending on model)

Monolith appliances fitted with an InfinitySpring or IceMaker must be connected to a water supply. The water pressure must be between 0.28-0.62MPa.

The supply hose delivered with the appliance must be used to feed water to the InfinitySpring/IceMaker.

If the degree of hardness of the water at the installation location is high, we recommend installing a water softener. A filter must also be used in case solids such as sand are contained in the water.

All devices and systems used to supply the appliance with water must meet the relevant applicable provisions in your region.

All appliances fitted with InfinitySpring or IceMaker have a water filter which is located in the front section of the appliance base. The water filter must be replaced regularly. An InfinitySwipe alarm reminds you when it is time to replace the water filter.

Warnings

- Water connection work must not be performed if the appliance is connected to an electrical socket.
- A shut-off valve must be installed between the hose line and the mains water supply in order that the water supply can be stopped if necessary. The shut-off valve must not be installed behind the appliance.
- The connection to the water supply must only be undertaken by a trained and licensed plumber.
- The water quality must comply with the drinking water regulations for the region in which the appliance is operated.
- The IceMaker is solely for the purpose of producing ice cubes in normal household quantities and must only be used with water appropriate for this purpose.
- All repairs and work on the InfinitySpring/IceMaker must only be undertaken by customer service employees or other trained individuals.
- The manufacturer assumes no responsibility for damage as a result of devices or water pipes located between the solenoid valve and the water supply.

Electrical safety

- The appliance must only be operated using alternating current.
- The permitted voltage and frequency according to the appliance design must be adhered to for the relevant country.
- Power sockets must be earthed and electrically protected in accordance with regulations.
- Power sockets must not be located behind the appliance and must be easily accessible in order to be able to disconnect the appliance from the mains if necessary.
- A separate circuit is recommended for the appliance in order to prevent defrosting or spoiling food as a result of an electricity failure caused by other appliances.

WARNING!

Risk of fatal electric shock.

Do not connect the appliance to unearthed power sockets.

Failure to observe this instruction may result in severe injuries or death.

WARNING!

Fire hazard

- Do not connect the appliance using an extension cable or multi-socket. There is a risk of overheating or fire due to potentially poor connector contacts.
- Do not connect the appliance using an inverter. There is a risk of overheating and a fire hazard for the control electronics due to imperfect sine wave voltage of various inverters.

Failure to observe these instructions may result in fire, severe injuries or death.

Do you still have questions? If so, please contact your Liebherr sales representative or authorised dealer.

Whilst every effort is made to ensure all specifications and information in this brochure are accurate, Liebherr reserves the right to make changes without notification. Where actual appliance measurements, specifications, and ratings are crucial, we recommend that the actual appliance installation instructions that accompany each appliance be checked. Liebherr will not be liable for any loss.

Subject to changes. For latest available data, see home.liebherr.com/monolith.

home.liebherr.com.au/monolith