



User Guide

Quality, Design and Innovation



home.liebherr.com/fridge-manuals







LIEBHERR



Contents

1	The appliance at a glance.....	3
1.1	Included in delivery.....	3
1.2	Overview of appliance and equipment.....	3
1.3	Special features.....	3
1.4	Range of appliance use.....	4
1.5	Sound emission of the appliance.....	4
1.6	Conformity.....	4
2	General safety instructions.....	4
3	Start-up.....	6
3.1	Setup conditions.....	6
3.2	Appliance dimensions.....	7
3.3	Transporting the appliance.....	7
3.4	Unpacking the appliance.....	7
3.5	Removing the transport lock.....	7
3.6	Installing the door handle.....	7
3.7	Mounting the anti-tipping device.....	7
3.8	Setting up the appliance.....	8
3.9	Leveling out the appliance.....	8
3.10	Setting up multiple appliances.....	9
3.11	After setup.....	9
3.12	Disposal of packaging.....	9
3.13	Reversing the door opening direction.....	9
3.14	Aligning the door.....	16
3.15	Connecting the appliance.....	17
3.16	Switching on the appliance (first use).....	17
4	Storage.....	18
4.1	Information regarding storing items.....	18
5	Use.....	18
5.1	Control and display elements.....	18
5.1.1	Status display.....	18
5.1.2	Display symbols.....	18
5.1.3	Acoustic signals.....	19
5.2	Navigation.....	19
5.2.1	Navigation with the touch display.....	19
5.2.2	Settings menu.....	20
5.2.3	Customer menu.....	20
5.2.4	General rules.....	20
5.3	Appliance functions.....	20
5.3.1	Overview of functions.....	20
5.3.2	Switching appliance on and off	21
5.3.3	Temperature	21
5.3.4	Temperature recording	22
5.3.5	Lighting	22
5.3.6	Settings menu access protection	23
5.3.7	Access codes.....	23
5.3.8	Maintenance interval reminder	24
5.3.9	Language	25
5.3.10	Date and time	25
5.3.11	Temperature unit	25
5.3.12	Display brightness	25
5.3.13	Alarm Sound.....	26
5.3.14	Key Sound.....	26
5.3.15	WiFi connection	26
5.3.16	LAN connection	28
5.3.17	Info.....	29
5.3.18	Operating hours	29
5.3.19	Software.....	29
5.3.20	Defrosting	29
5.3.21	Data download / Datalogging.....	30
5.3.22	Sensor calibration	30
5.3.23	Temperature alarm	31
5.3.24	Door alarm	32
5.3.25	Light alarm	32
5.3.26	Alarm simulation	33
5.3.27	Alarm log	33
5.3.28	Alarm relay	33
5.3.29	Demo mode	34
5.3.30	Factory reset	34
5.4	Messages.....	35

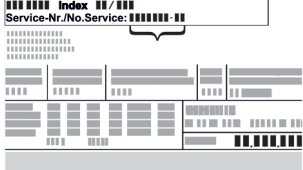
5.4.1	Warnings.....	35
5.4.2	Reminders.....	36
6	Equipment.....	37
6.1	Safety lock.....	37
6.2	Sensors.....	37
6.3	Sensor info	37
6.4	Interfaces.....	38
7	Maintenance.....	38
7.1	Maintenance schedule.....	38
7.2	Defrosting the appliance.....	39
7.3	Cleaning the appliance.....	40
7.4	Replacing appliance battery.....	41
8	Customer support.....	41
8.1	Technical data.....	41
8.2	Technical malfunction.....	42
8.3	Customer Service.....	42
8.4	Type plate.....	42
9	Shutting down.....	43
10	Disposal.....	43
10.1	Preparing appliance for disposal.....	43
10.2	Disposing of the appliance in an environmentally friendly manner.....	43
11	Additional information.....	43
12	Quick Start Guide for everyday use.....	45

The manufacturer is constantly working to improve all types and models. Therefore, please be aware that we reserve the right to make changes to the shape, equipment and technology.

Symbol	Explanation
	<p>Read instructions</p> <p>Please read the information in these instructions carefully to understand all of the benefits of your new appliance.</p>
	<p>Full instructions on the internet</p> <p>You can find detailed instructions on the internet using the QR code on the front of these instruction or by entering the service number at home.liebherr.com/fridge-manuals.</p> <p>The service number can be found on the serial tag:</p>  <p style="text-align: right;"><i>Fig. Example illustration</i></p>
	<p>Check appliance</p> <p>Check all parts for transport damage. If you have any complaints, please contact your agent or customer service.</p>
	<p>Differences</p> <p>These instructions apply to a range of models, so there may be differences. Sections that apply to certain models only are indicated by an asterisk (*).</p>

Symbol	Explanation
	Instructions and results Instructions are marked with a ▶. Results are marked with a ▷.
	Videos Videos about the appliances are available on the YouTube channel of Liebherr-Hausgeräte.

These operating instructions apply to:

- SRFvh 4001
- SRFvh 4011
- SRFvh 5501
- SRFvh 5511

1 The appliance at a glance

1.1 Included in delivery

Check all parts for transport damage. If you have any issues, please contact your dealer or Customer Service. (see 8.3 Customer Service)

The delivery contains the following parts:

- Freestanding appliance
- Equipment *
- Installation materials *
- Operating instructions
- Service brochure
- Quality certificate *
- Power cable
- Handle incl. screws and Torx tool
- Wall fastening kit

1.2 Overview of appliance and equipment

SRFvh 4001
SRFvh 5501

SRFvh 4011
SRFvh 5511

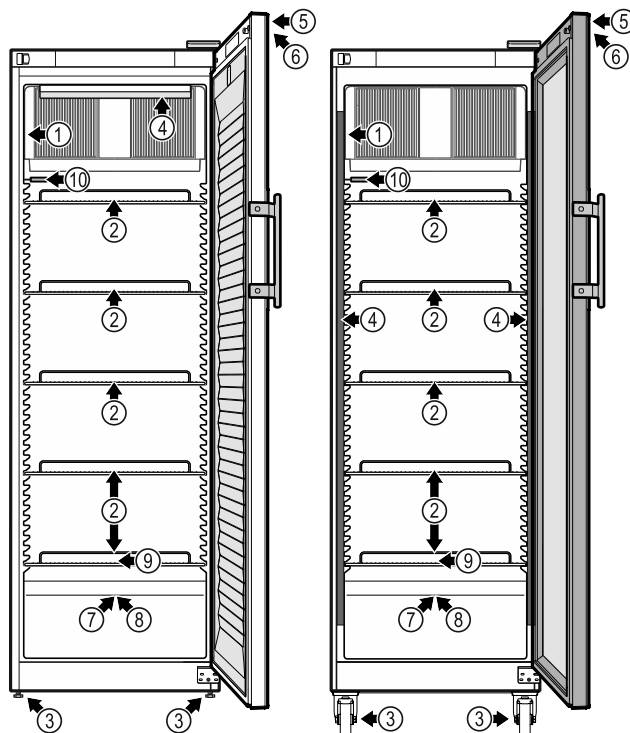

Fig. 1 Example illustration

- | Equipment | |
|------------------------------|--|
| (1) Type plate | (6) Control elements and temperature display |
| (2) Grid shelves | (7) Sensor feedthrough |
| (3) Adjusting feet/castors * | (8) Safety thermostat sensor |
| (4) Interior lighting * | (9) Defrost water drain |
| (5) Lock | (10) P sensor |

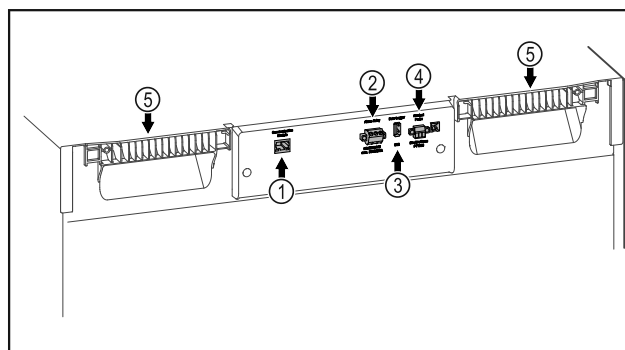

Fig. 2 Example illustration of the rear

- | Equipment | |
|---------------------------------|-----------------------------|
| (1) LAN/WiFi interface* | (4) Connection for P sensor |
| (2) Potential-free alarm output | (5) Carrying aid |
| (3) USB interface | |

1.3 Special features

Note

Accessories are available from Customer Service (see 8.3 Customer Service) and the Liebherr-Hausgeräte store at home.liebherr.com/shop/de/deu/zubehor.html.

General safety instructions

SmartModule

The appliance is equipped with a SmartModule.

This is a WiFi and LAN interface for the connection between the appliance and an external documentation and alarm system such as Liebherr SmartMonitoring.

SmartMonitoring is not available in all countries. Check availability via the QR code (see 5.3.15 WiFi connection) by entering your model.

Retrofitting drawers

Temperature qualification is required when retrofitting drawer systems in Liebherr refrigerators/freezers where these are used for temperature-sensitive materials such as chilled drugs and refrigerated products which are subject to specific standards requirements. Retrofitting drawers in Liebherr refrigerators/freezers can result in the goods stored becoming spoiled or damaged. The retrofitting must therefore be completed exclusively by authorized service providers from the manufacturer of the refrigerator/freezer.

1.4 Range of appliance use

Intended use

This laboratory refrigerator is suitable for professional storage of products at temperatures between 3 °C and 16 °C.

Typical products to be stored include research samples, reagents, laboratory inventory etc.

The appliance meets the requirements of DIN 13277 – Refrigerators and freezers for laboratory and medical applications.

It is necessary to use an independent alarm system with permanent monitoring if storing valuable or temperature-sensitive substances or products. This alarm system must be designed in such a way that every alarm state is immediately registered by a competent person who then takes appropriate measures.

Foreseeable incorrect use

Do not use the appliance for the following applications:

- Storage and cooling of:
 - Chemically unstable, flammable or corrosive substances
 - Blood, plasma or other body fluids for the purpose of infusion, application or introduction in the human body.
- Use in potentially explosive atmospheres.
- Use outdoors or in areas exposed to dampness and splashing water.

Any misuse of the appliance may result in damage to or spoilage of stored goods.

Climate classes

The climate class for your appliance is printed on the identification plate.

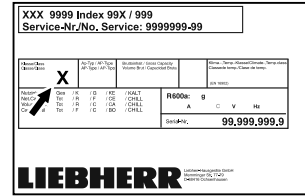

Fig. 3 Type plate

(X) The climate class states the ambient conditions in which the appliance can be operated safely.

Climate class (X)	max. room temperature	max. rel. humidity	rel.
7	35 °C	75%	

Note

The minimum permitted room temperature at the setup location is 10 °C.

Slight condensation may form on the glass door on the side walls if the boundary conditions are exceeded.

1.5 Sound emission of the appliance

The A-weighted emission sound pressure level during operation of the appliance is below 70 dB(A) (sound power rel.1 pW).

1.6 Conformity

The refrigerant circuit has been tested for leaks.

The full text of the EU Declaration of Conformity is available on the following website: www.liebherr.com

2 General safety instructions

Please keep these operating instructions in a safe place so you can refer back to them at any time.

If you pass the appliance on, please hand these operating instructions to the new owner.

Read these operating instructions before use in order to use the appliance safely and correctly. Follow the instructions, safety instructions and warning messages included at all times. They are important for ensuring you can operate and install the appliance safely and without any problems.

Dangers for the user:

- This appliance may only be used by specialist and laboratory personnel who have been trained for this purpose and are

familiar with all the safety measures for work in a laboratory. Children and persons with impaired physical, sensory or mental abilities or with a lack of experience and knowledge may not commission or operate this appliance.

- The socket must be easily accessible so that the appliance can be disconnected quickly from the electricity in an emergency. It must not be located in the area behind the appliance.
- Always hold the plug of the cable when disconnecting the appliance from the power supply. Do not pull on the cable.
- Remove the plug or disconnect via the fuse if there is a malfunction.
- **WARNING:** Do not damage the power cable. Do not operate the appliance with a faulty power cable.
- **WARNING:** Multi-sockets/power distributors and other electronic appliances (such as halogen transformers) may not be placed and operated behind appliances.
- **WARNING:** Do not block the ventilation openings in the appliance housing or in the installation housing.
- Repairs and work on the appliance may only be carried out by Customer Service or other specifically trained qualified personnel.
- Always follow the instructions when assembling, connecting and disposing of the appliance.

Risk of fire:

- The refrigerant contained within the appliance (specifications on the type plate) is environmentally friendly, but flammable. Leaking refrigerant can ignite.
 - **WARNING:** Do not damage the refrigerant circuit.
 - Do not handle ignition sources inside the appliance.
 - **WARNING:** Do not use electrical appliances inside the food storage compartments of the appliance, unless they are of the type recommended by the manufacturer.
 - If refrigerant leaks: Remove naked flames or ignition sources located near the area of the leak. Ventilate the room well. Contact Customer Service.
- Do not operate the appliance near explosive gases.
- Do not store or use gasoline or other flammable gases and liquids near the appliance.

- Do not store explosive substances such as aerosol cans with a flammable propellant in this appliance. You can recognize such spray cans by the printed list of contents or by a flame symbol. Any leaking gases can be ignited by electrical components.
- Keep lit candles, lamps and other objects with naked flames away from the appliance so they do not cause a fire.
- Alcoholic liquids or other containers holding alcohol must always be tightly sealed for storage purposes. Any leaking alcohol can be ignited by electrical components.

Risk of falling or toppling over:

- **WARNING:** To avoid a hazard due to instability of the appliance, it must be fixed in accordance with the instructions.
- Do not stand on the base, drawers, doors etc. or use them as improper supports.

Danger of frostbite, feeling of numbness and pain:

- Avoid prolonged skin contact with cold surfaces or chilled/frozen food or take protective measures, e.g. wear gloves.

Risk of injury and damage:

- **WARNING:** Do not use mechanical devices or other means to accelerate the defrosting process, other than those recommended by the manufacturer.
- **WARNING:** Risk of injury due to electric shock! There are live electrical parts under the cover.
Have the LED interior lighting replaced or repaired only by Customer Service or other suitably trained professionals.
- **NOTICE:** The appliance must only be operated using original manufacturer accessories or accessories from other providers approved by the manufacturer. The user bears the risk of using accessories which are not approved.

Risk of crushing:

- Do not reach into the hinge when opening and closing the door. Fingers may get trapped.

Specialist personnel qualifications:

The appliance may only be installed, tested, maintained, and commissioned by specialist personnel who are familiar with

Start-up

the installation, commissioning, and operation of the appliance.

Specialist personnel are persons who, on account of their specialist training, knowledge and experience as well as their knowledge of the relevant standards, are able to assess and perform the work assigned to them and identify potential hazards. They must have training, instruction, and authorization to work on the appliance.

Symbols on the device:



The symbol may be located on the compressor. It refers to the oil in the compressor and refers to the following danger: **Can be fatal if swallowed or inhaled.** This notice only applies for recycling. There is no danger during normal operation.



WARNING: Risk of fire / flammable materials. The symbol is located on the compressor and indicates the danger from flammable materials. Do not remove the label.

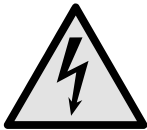

The symbol is located on the back of the appliance near the alarm relay and indicates the following danger: **Electric shock!** Even if an appliance is disconnected from the mains there may still be extraneous voltage. Do not remove the label.



This label or a similar one may be located on the rear of the appliance. This label indicates that there are vacuum insulation panels (VIP) or perlite panels in the door and/or housing. This notice only applies for recycling. Do not remove the label.



This label or a similar one may be located on the rear of the appliance. It refers to the Li-ion battery installed. This notice only applies for recycling. Do not remove the label.

Li-ion

Observe the warning messages and other detailed information in the other sections:

	DANGER	Indicates an immediately hazardous situation, which if not avoided, will result in death or serious injury.
	WARNING	Indicates a hazardous situation, which if not avoided, could result in death or serious injury.
	CAUTION	Indicates a hazardous situation, which if not avoided, could result in minor or moderate injury.
	NOTICE	Indicates a hazardous situation, which if not avoided, could result in damage to property.
	Note	Indicates useful advice and tips.

3 Start-up

3.1 Setup conditions



WARNING

Risk of fire due to moisture!

If live parts or the power cord get wet, this can cause a short circuit.

- ▶ The appliance is designed for use in enclosed spaces. Do not operate the appliance in open space or in damp areas or where there is spray.

3.1.1 Setup location



WARNING

Leaking refrigerant and oil!

Fire. The refrigerant contained within the appliance is environmentally friendly, but flammable. The oil contained within the appliance is flammable. Escaping refrigerant and oil can ignite if they are of high enough concentration and are exposed to an external heat source.

- ▶ Do not damage the pipelines of the coolant circuit and the compressor.

- Do not setup the appliance in direct sunlight, next to an oven, radiator or similar.
- The best place to set up the appliance is a dry and well ventilated room.
- If the appliance is set up in a very humid environment, condensation can form on the outside of the appliance. Always ensure sufficient airflow and ventilation in the setup location.
- The more refrigerant there is in the appliance, the larger the space it is installed in must be. If the space is too small, any leak may create a flammable mixture of gas and air. For every 8 g of refrigerant, the installation space must be at least 1 m³. Specifications on the refrigerant in the appliance can be found on the serial tag plate inside the appliance.
- The floor of the setup location must be horizontal and even.
- The setup location must be able to withstand the weight of the appliance plus the weight when stocked to maximum capacity. (see 8.1 Technical data)
- Use in hazardous areas is not permitted.

3.1.2 Electrical connection



WARNING

Danger of fire due to incorrect positioning!

If the power supply cable or plug touches the back of the appliance, the vibration can damage the power supply cable or the plug resulting in a short circuit.

- ▶ Make sure the power supply cable is not trapped under the appliance when you position the appliance.
- ▶ Install the appliance so that it does not touch any plugs or power cables.
- ▶ Do not connect any appliances to sockets in the area of the back of the appliance.
- ▶ Do **not** place and operate power strips/power distributors and other electronic devices (such as halogen transformers) at the back of the appliances.

3.2 Appliance dimensions

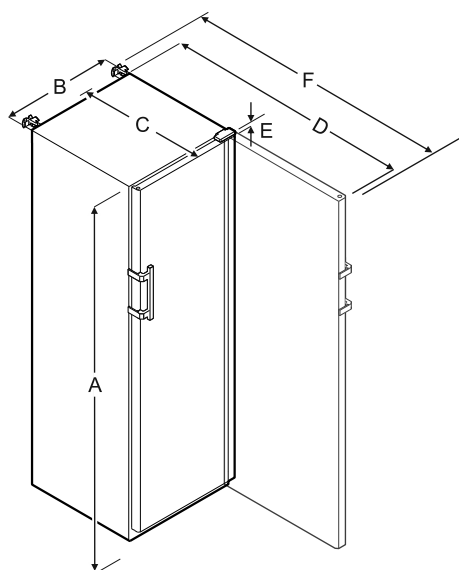

	SRFvh 4001/4011	SRFvh 5501/5511
A	1884 mm	1793 mm
B	597 mm	747 mm
C	664 mm	779 mm
D	1203 mm	1468 mm
E	23 mm	23 mm
F	1241 mm	1506 mm

- A = appliance height including feet/castors
- B = appliance width without handle (handle depth = 45 mm)
- C = appliance depth without handle (handle depth = 45 mm)
- D = appliance depth with door open
- E = hinge height
- F = appliance depth with protruding handle and anti-tipping device

3.3 Transporting the appliance



WARNING

There is a risk of injury from pieces of broken glass.* When transporting at an altitude of more than 1500 m, the glass panes of the door may break. This can result in sharp-edged fragments, which can cause serious injuries.

- ▶ Adopt suitable protective measures.
- ▶ On initial setup: Transport the appliance in its packaging.
- ▶ When transporting after initial setup (e.g. relocation): Transport the appliance unloaded.
- ▶ Transport the appliance upright.
- ▶ Use two people when transporting the appliance.

3.4 Unpacking the appliance

- ▶ Check the appliance and the packaging for transport damage. Contact the supplier immediately if you suspect any damage. Do not connect the appliance to the power supply.
- ▶ Remove all packaging materials from the rear or the side walls of the fridge that may prevent proper installation or prevent air flow and ventilation.

3.5 Removing the transport lock

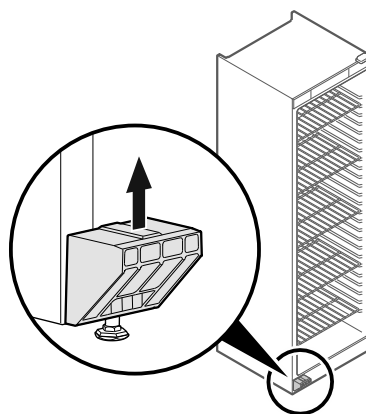

Fig. 4
 ▶ Remove transport lock in upwards direction.
 ▷ Base holder remains on the appliance.

3.6 Installing the door handle

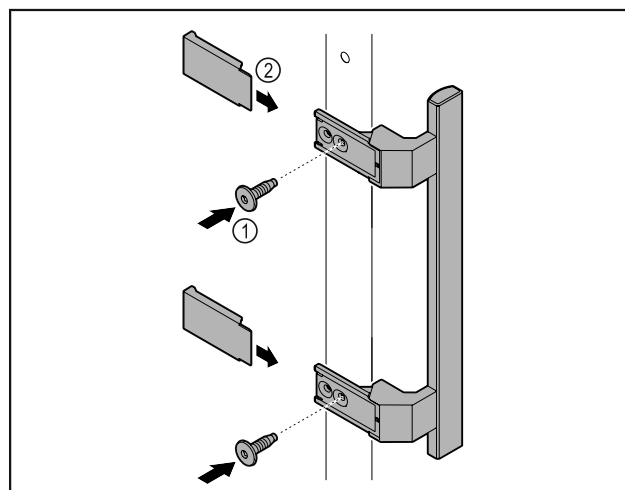

Fig. 5
 ▶ Attach handle from accessory kit to the door using supplied screws Fig. 5 (1).
 ▶ Put on cover Fig. 5 (2).

3.7 Mounting the anti-tipping device

Tools



Fig. 6
 Prevent appliance from tipping over.

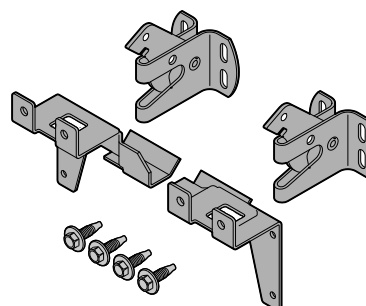

Start-up

Fig. 7

The anti-tipping device, consisting of two retaining parts, two retaining hooks and four screws (4 x 14), is included with the appliance.

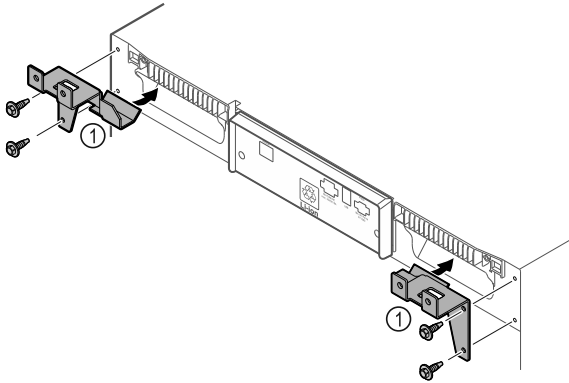

Fig. 8

- ▶ Mount retaining parts Fig. 8 (1) on the appliance using the supplied screws.
- ▶ Push appliance with retaining parts mounted against the wall.

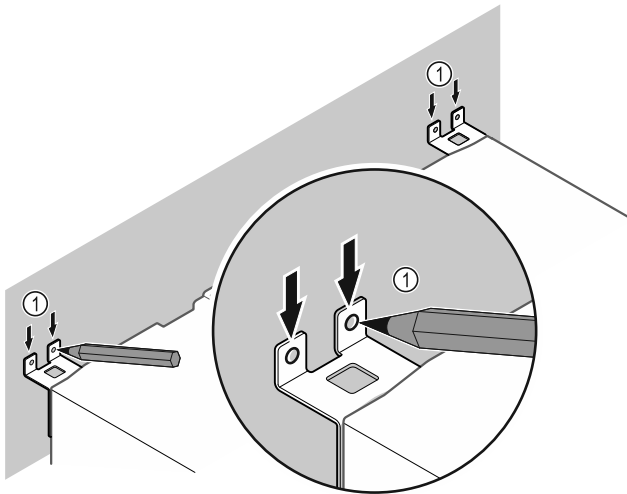

Fig. 9

- ▶ Make markings on the wall Fig. 9 (1).
- ▶ Remove appliance.

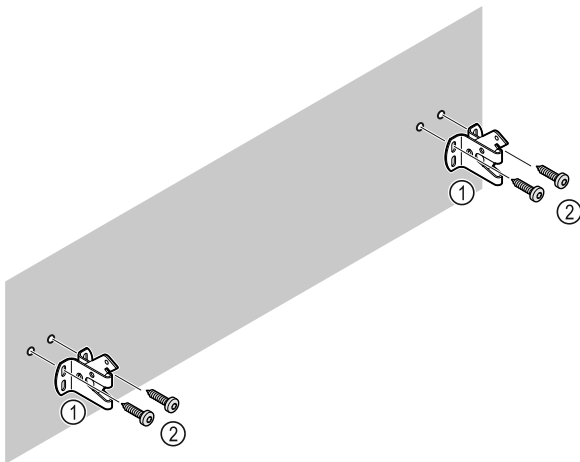

Fig. 10

Use fixing material (e.g. wall anchors) which is appropriate for the nature of the wall (wood, concrete) and sufficient attachment points.

- ▶ Attach retaining hooks.

3.8 Setting up the appliance



CAUTION

Risk of injury and damage.

- ▶ Use 2 people to set up the appliance.



CAUTION

Risk of injury and damage.

The door can strike against the wall and become damaged as a result. In the case of glass doors, the damaged glass can cause injuries.

- ▶ Protect the door from striking against the wall. Attach a door stopper, e.g. felt stopper, to the wall.

- ▶ Connect all necessary components (e.g. power cable) to the back of the appliance and route to the side.

Note

Cables can be damaged.

- ▶ Do not crush the cable when pushing the appliance back.

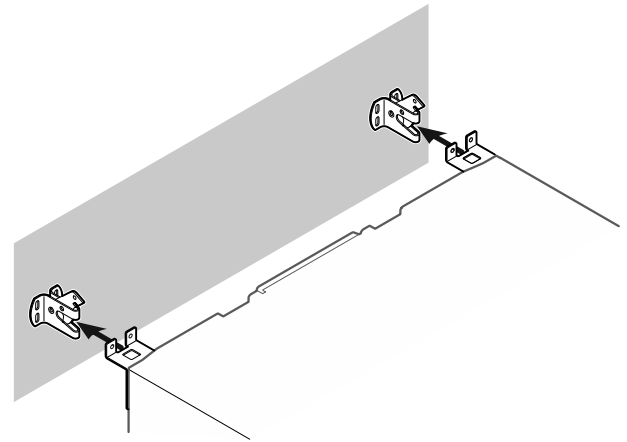

Fig. 11

- ▶ Slide the appliance up against the wall so that the retaining parts latch into the retaining hooks.
- ▷ The appliance is now secured against tipping.
- ▷ It can be released by folding back the retaining hooks.

3.9 Leveling out the appliance

NOTICE

Appliance body can become deformed and door will not close.

- ▶ Align appliance horizontally and vertically.
- ▶ Compensate for uneven floors using adjustable feet.



WARNING

Incorrect height adjustment of the adjustable foot!

Severe or fatal injuries. Incorrect height adjustment can cause the bottom part of the adjustable foot to come loose and the appliance to tip over.

- ▶ Do not unscrew the adjustable foot too far.

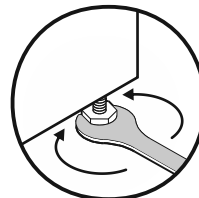

Fig. 12 *

Raising appliance:

- ▶ Turn adjustable foot clockwise.

Lowering appliance:

- ▶ Turn adjustable foot counterclockwise.

3.10 Setting up multiple appliances

NOTICE

Risk of damage due to condensation between the side walls.

- ▶ Do not set up the appliance directly next to another refrigeration appliance.
- ▶ Set up appliances with a space of 3 cm between appliances.
- ▶ Only set up multiple appliances up to temperatures of 35 °C and 65 % humidity next to one another.
- ▶ At higher levels of humidity, increase the space between appliances.

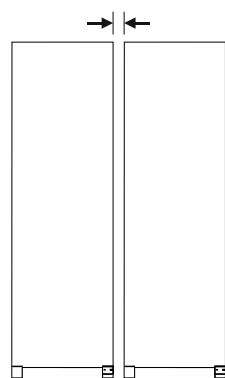

Fig. 13 Side-by-side set up

Note

A side-by-side kit is available as an accessory via Liebherr Customer Service. (see 8.3 Customer Service)

3.11 After setup

- ▶ Peel off the protective films. *
- ▶ Clean the appliance. (see 7.3 Cleaning the appliance)
- ▶ If necessary: Disinfect the appliance.
- ▶ Keep the invoice so you have the appliance and dealer information available if needed.

3.12 Disposal of packaging



WARNING

Danger of suffocation from packaging materials and films!

- ▶ Do not allow children to play with packaging materials.

The packaging is made from recyclable materials:

- Corrugated card/cardboard
- Parts made of foamed polystyrene
- Films and bags from polyethylene
- Packing bands from polypropylene
- Wood frame nailed together with a polyethylene window*

- ▶ Take the packaging material to an official collection point.



3.13 Reversing the door opening direction

Tools

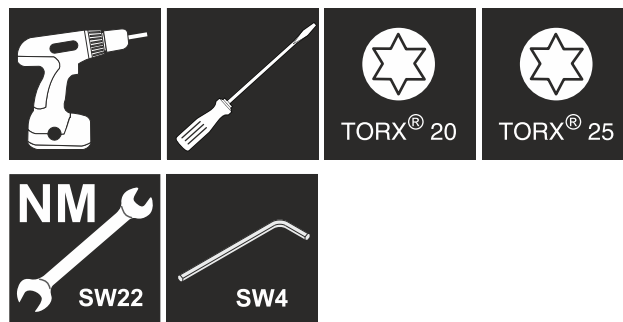

WARNING

Risk of injury if the door is not reversed correctly!

- ▶ The door may only be reversed by qualified personnel.



WARNING

Risk of injury and material damage due to heavy door!

- ▶ Only perform the conversion if you can carry a weight of 25 kg.
- ▶ Always have someone help you carry out the conversion.

NOTICE

Live parts!

Damage to electrical components.

- ▶ Disconnect the power plug before reversing the door.

- ▶ Open the door.

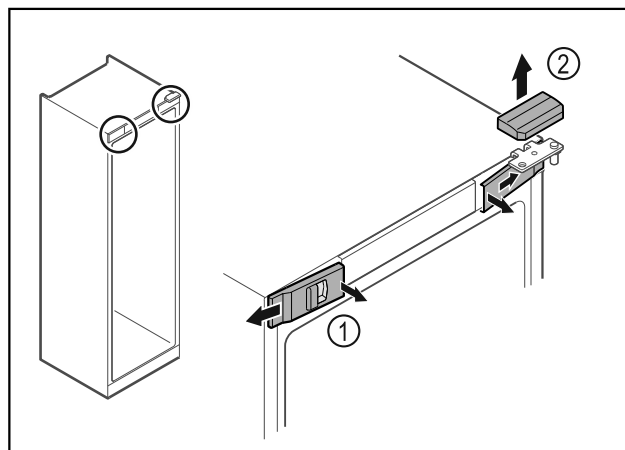

Fig. 14

- ▶ Unlatch the front covers Fig. 14 (1) on the inside and remove them sideways.
- ▶ Lift off the upper cover Fig. 14 (2).

Start-up

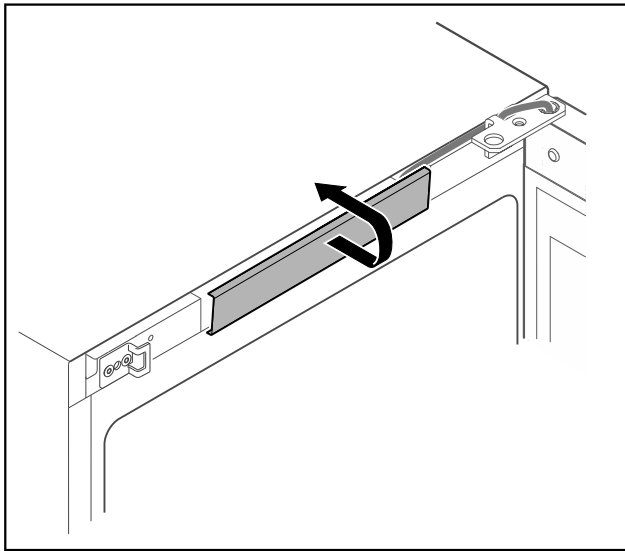

Fig. 15

- ▶ Unlatch the middle cover and remove it.

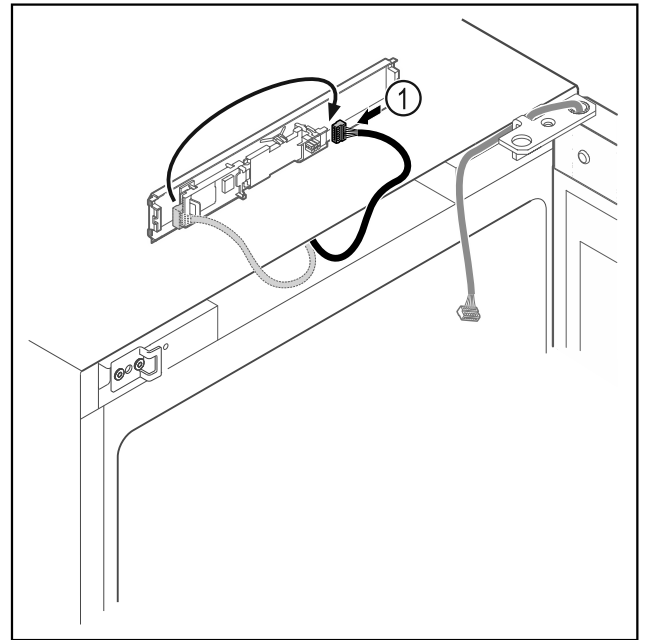

Fig. 17

- ▶ Connect the plug Fig. 17 (1) to the circuit board.

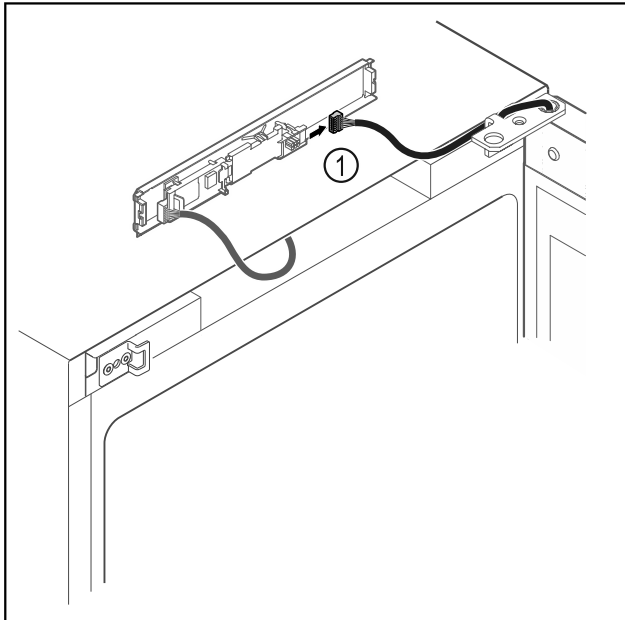

Fig. 16

- ▶ Disconnect the plug Fig. 16 (1) from the circuit board.

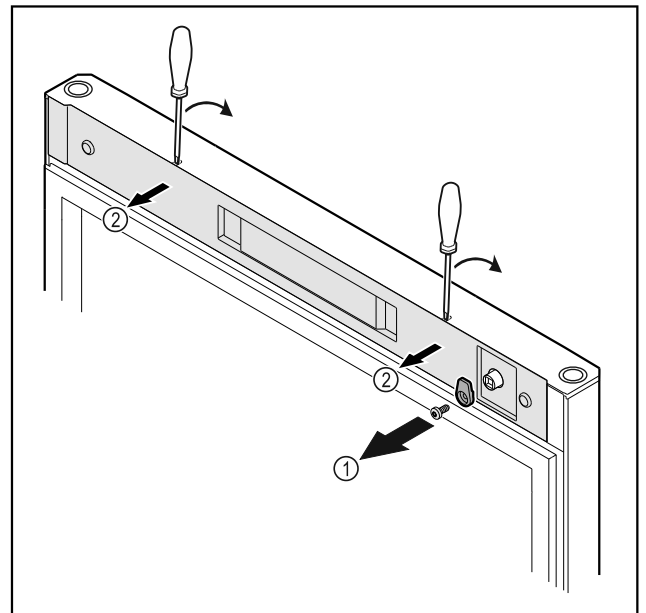

Fig. 18

- ▶ Unscrew the door latch Fig. 18 (1).
- ▶ Unlatch the cover Fig. 18 (1) with a small screwdriver and remove it.

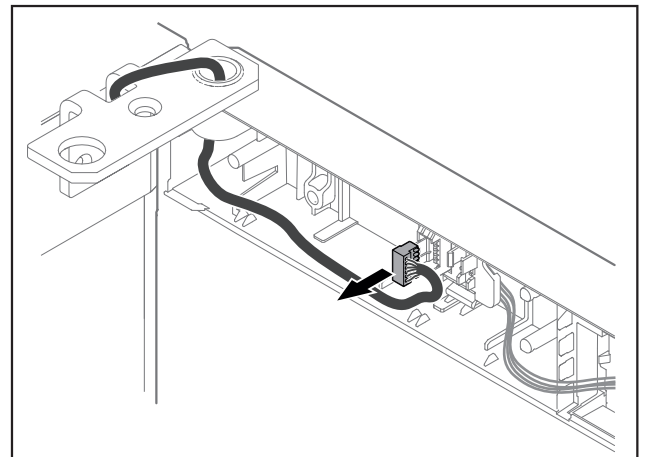

Fig. 19

- ▶ Remove the plug from the plug holder.

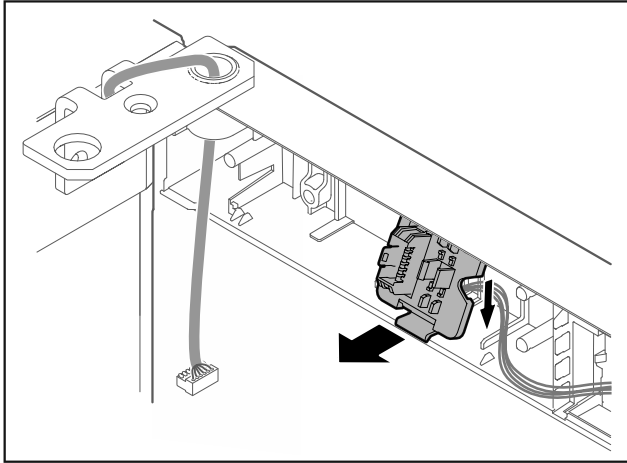

Fig. 20 The installation position of the plug holder can be rotated by 180°.

- ▶ Disengage the plug holder.

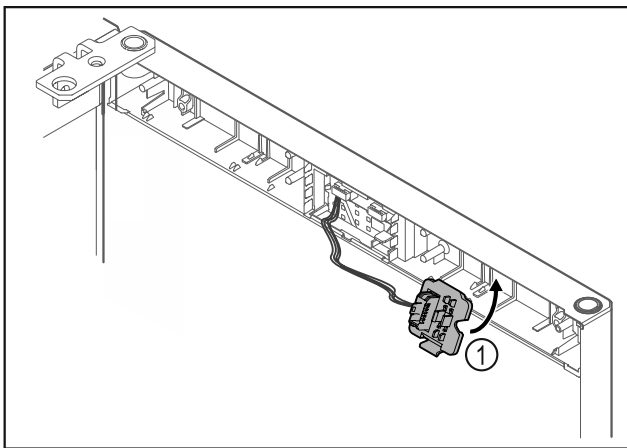

Fig. 21

- ▶ Snap in the plug holder Fig. 21 (1) on the opposite side.

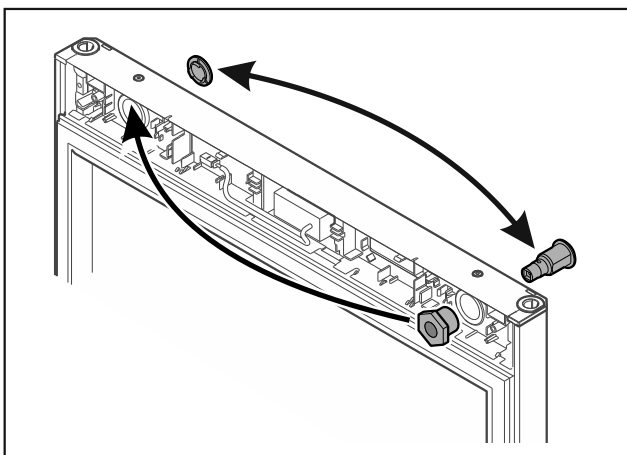

Fig. 22

- ▶ Put the lock and cover on the opposite side.

NOTICE
 Risk of injury if the door tips out!
 ▶ Hold the door.

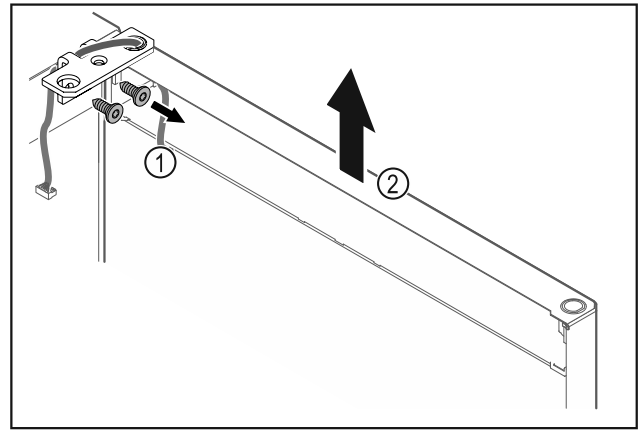

Fig. 23

- ▶ Unscrew the hinge Fig. 23 (1).
- ▶ Lift the door with the hinge straight up by Fig. 23 (2) roughly 200 mm and take it off.
- ▶ Carefully place the door on a soft surface.

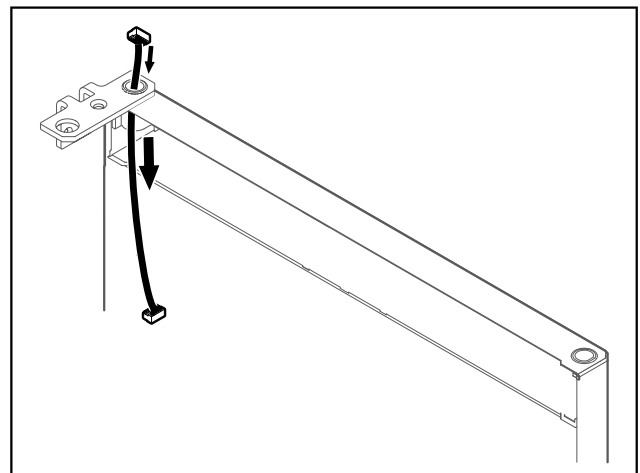

Fig. 24

- ▶ Carefully pull out the cable.

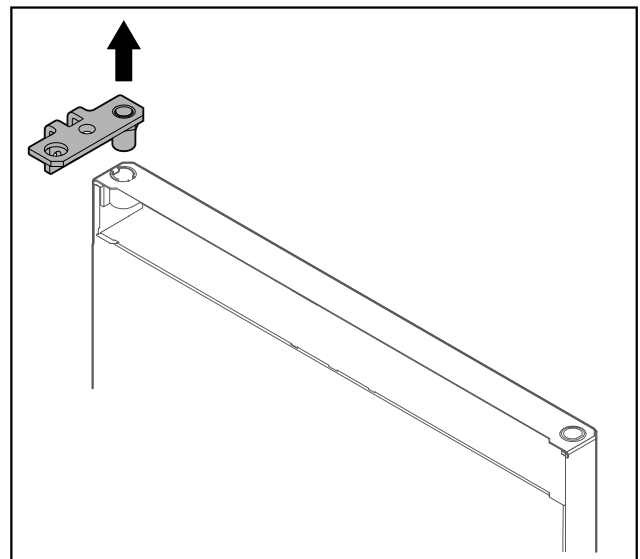

Fig. 25

- ▶ Pull out the hinge.

Start-up

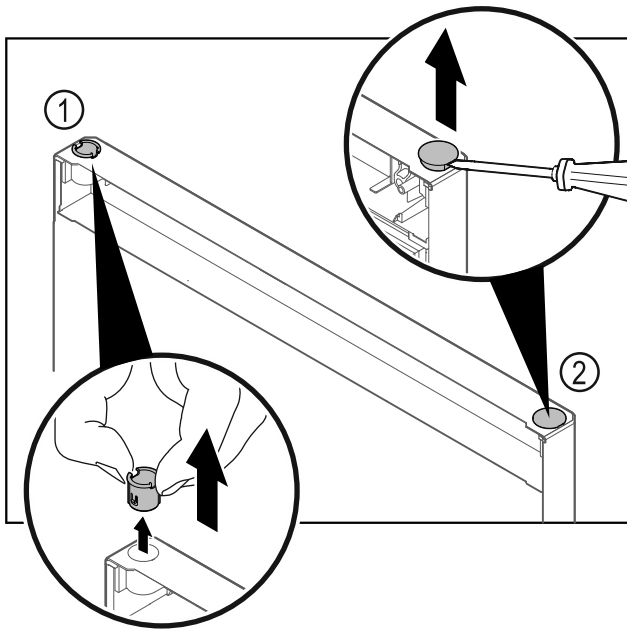

Fig. 26

- ▶ Pull out the hinge bushing Fig. 26 (1) with your fingers.
- ▶ Carefully lift the cover plug Fig. 26 (2) with a slotted screwdriver and pull it out.

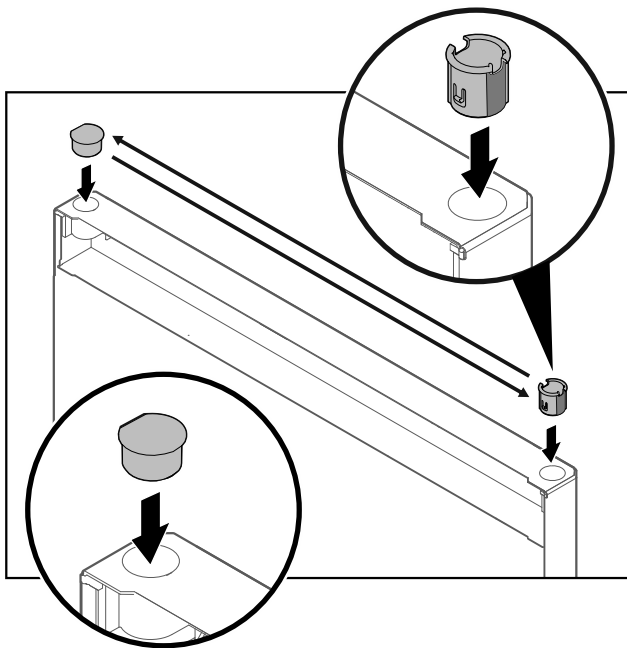

Fig. 27

- ▶ Insert hinge bushing and cover plug on the opposite side (the flattened sides face outwards).

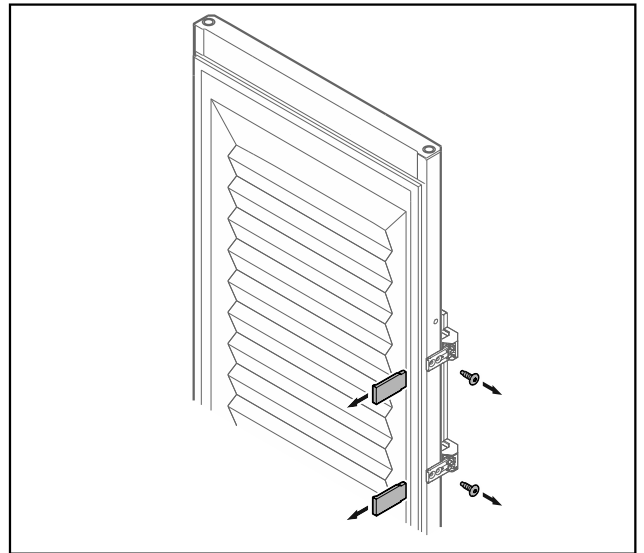

Fig. 28 Insulated door*

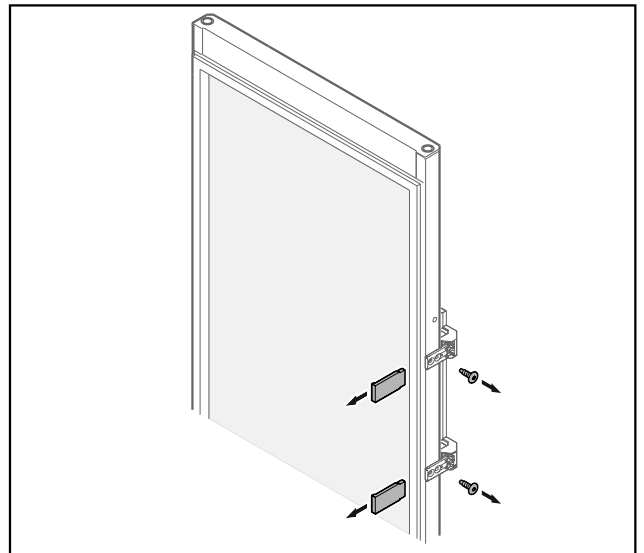

Fig. 29 Glass door*

- ▶ Remove the panels.
- ▶ Unscrew the handle.

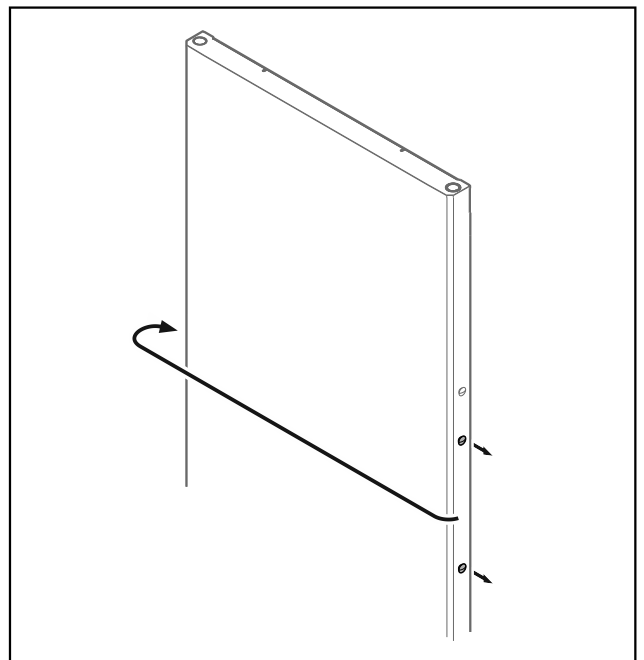

Fig. 30

- ▶ Put the stopper on the opposite side.

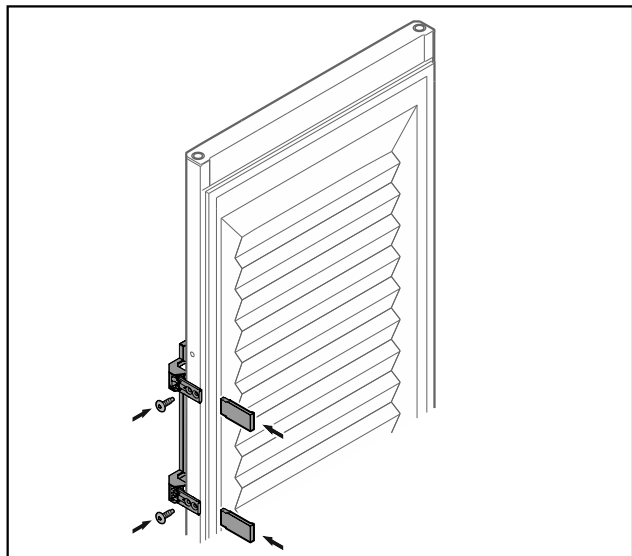

Fig. 31 Insulated door*

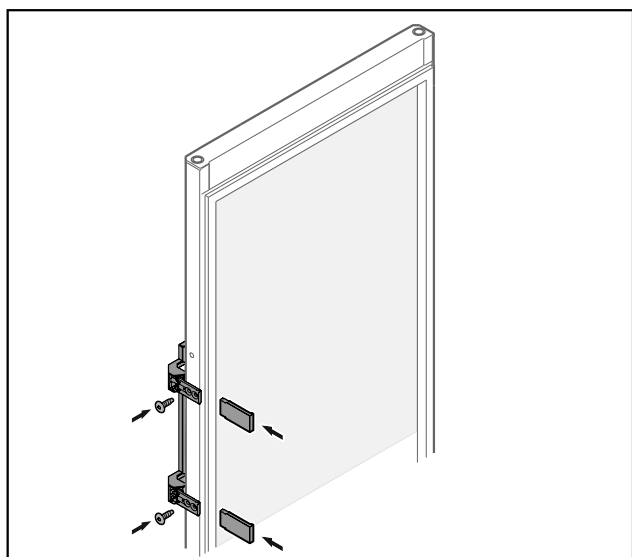

Fig. 32 Glass door*

- ▶ Screw the handle onto the opposite side.
- ▶ Attach the panels.

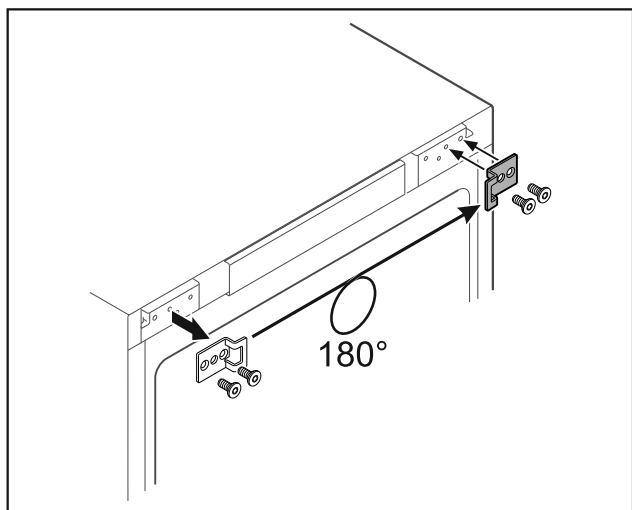

Fig. 33

- ▶ Put the closing bracket on the opposite side.

Note

The holes are pre-marked and must be pierced with the self-tapping screws.

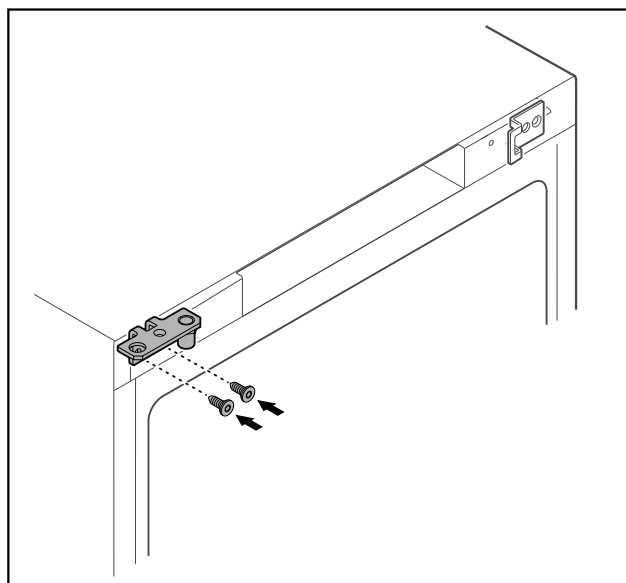

Fig. 34

- ▶ Move the hinge to the opposite side.



WARNING

Risk of injury and material damage if the door tips out!

- ▶ Tighten the bearing pins to the specified torque.

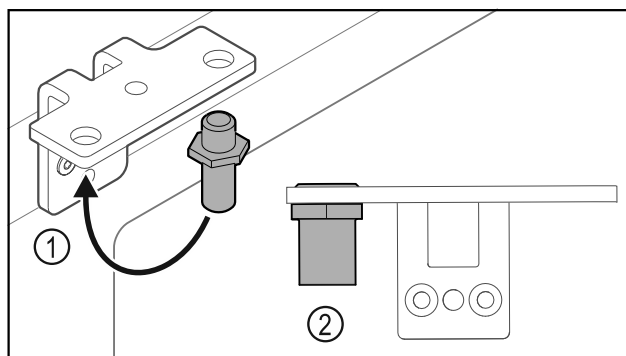

Fig. 35

- ▶ Put the pin back into the hinge Fig. 35 (1).
- ▶ Tighten the pin Fig. 35 (2) to a **torque of 12 Nm**.
- ▶ Unscrew the hinge again.

NOTICE

Risk of injury due to tensioned spring!

- ▶ Do not disassemble the door closing system Fig. 36 (1).

Start-up

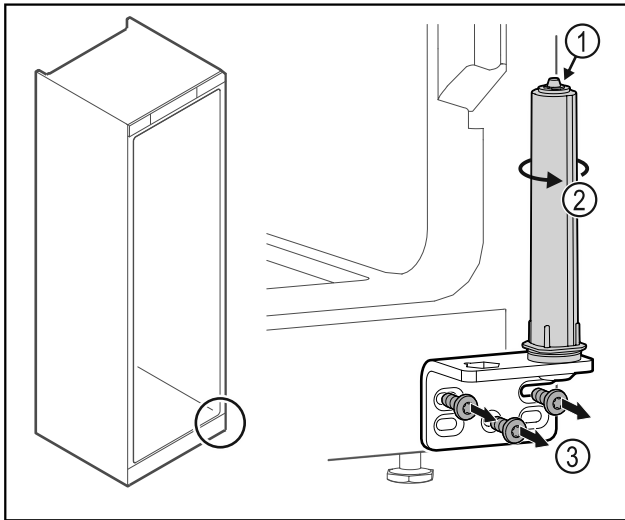

Fig. 36

- ▶ Turn the closing system Fig. 36 (2) until it clicks.
- ▷ The tension of the closing system is released.
- ▶ Unscrew the hinge Fig. 36 (3).

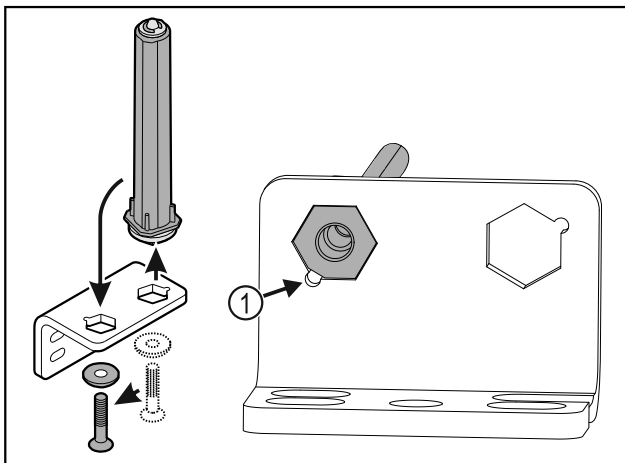

Fig. 37

- ▶ Put the door closing system in the hinge.
- ▶ Make sure the pin chamfer Fig. 37 (1) faces the round hole when you put it in.

-or-

Note

- Incorrect alignment of the height adjustment washers. Nuts no longer have sufficient hold.
- ▶ The washer must lock into the underside of the closing system.

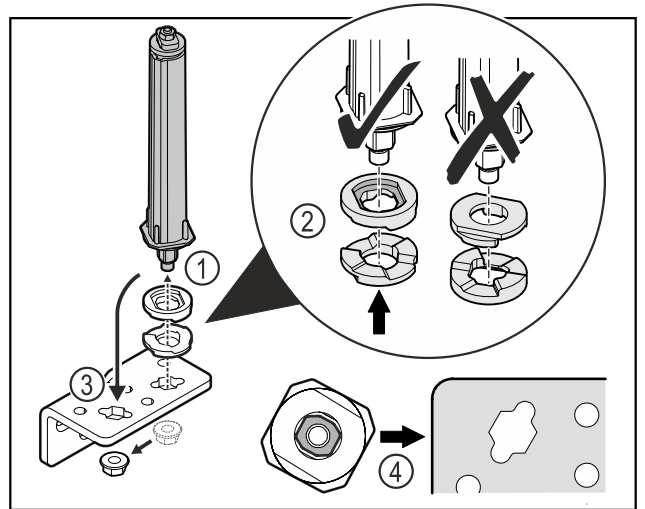

Fig. 38

- ▶ Loosen the nut and remove the door closing system Fig. 38 (1).
- ▶ Observe the correct alignment of the height adjustment washers Fig. 38 (2).
- ▶ Put the door closing system in the hinge fix in place with the nut Fig. 38 (3).
- ▶ Observe the correct alignment of the door closing system when doing so Fig. 38 (4).

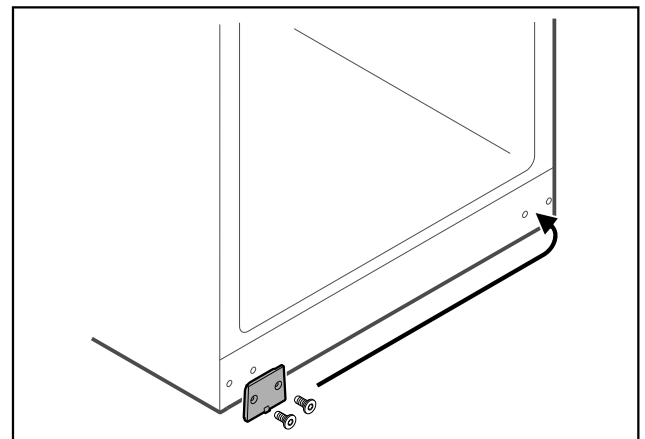

Fig. 39

- ▶ Put the cover plate on the opposite side.

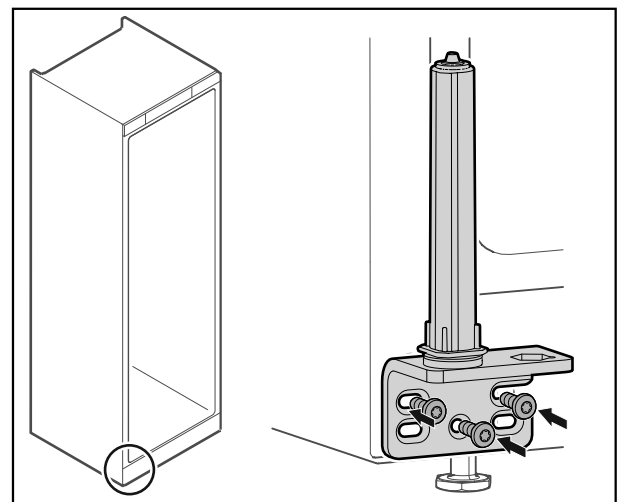

Fig. 40

- ▶ Screw the hinge onto the opposite side.

Note

Correct alignment and tension are important for the closing system to work properly.

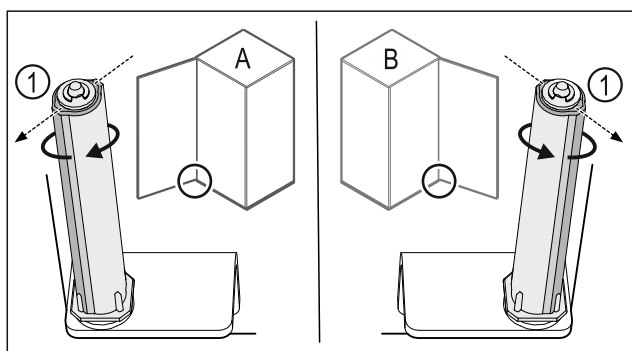

Fig. 41 Left-hinged (A) / Right-hinged (B)

- ▶ Turn the closing system against the resistance until the bar of the closing system Fig. 41 (1) points outwards.
- ▷ The closing system automatically stays in this position.
- ▷ The closing system is now aligned and pretensioned.

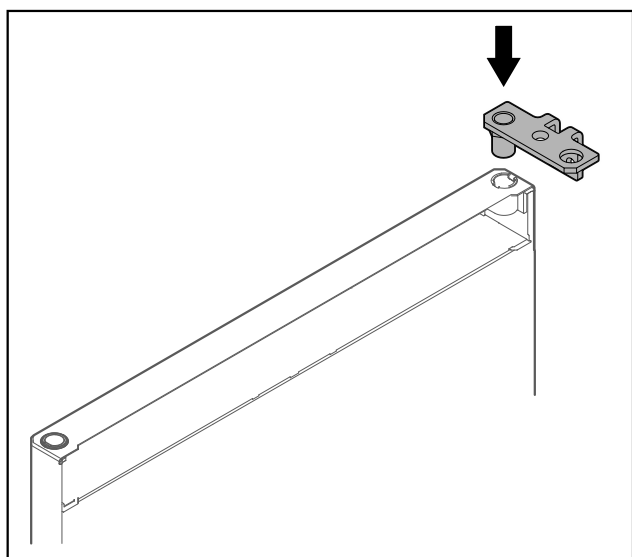

Fig. 42

- ▶ Put the hinge into the door.

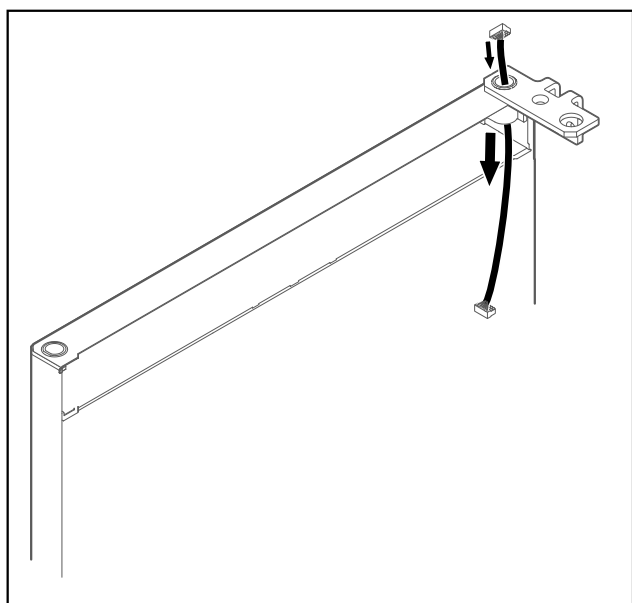

Fig. 43

- ▶ Carefully push the cable through.

NOTICE

Risk of injury if the door tips out!

- ▶ Hold the door.

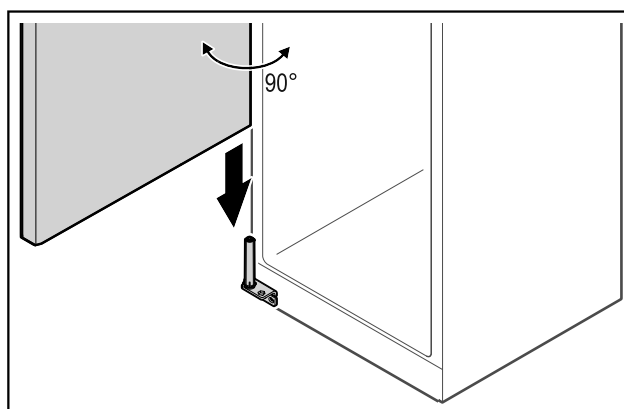

Fig. 44

- ▶ Together with a second person, lift the door from the ground.
- ▶ Carefully put the door on the closing system with the door opened at a 90° angle.

NOTICE

Material damage due to incorrect mounting!

- ▶ Do not pinch the cable when mounting the hinge.

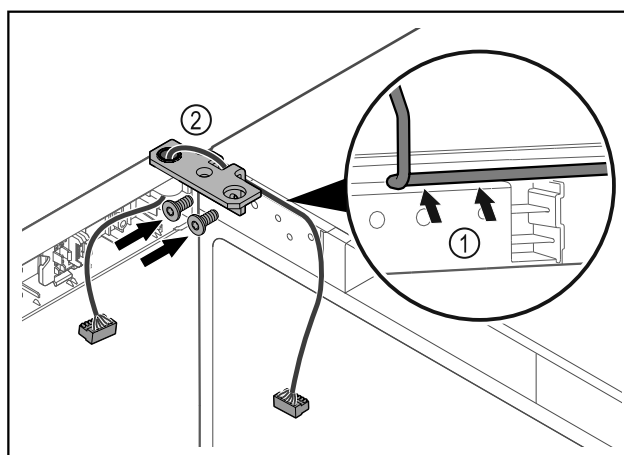

Fig. 45

- ▶ Feed the cable through the recess in the hinge and lay it carefully Fig. 45 (1).
- ▶ Screw on the hinge Fig. 45 (2).

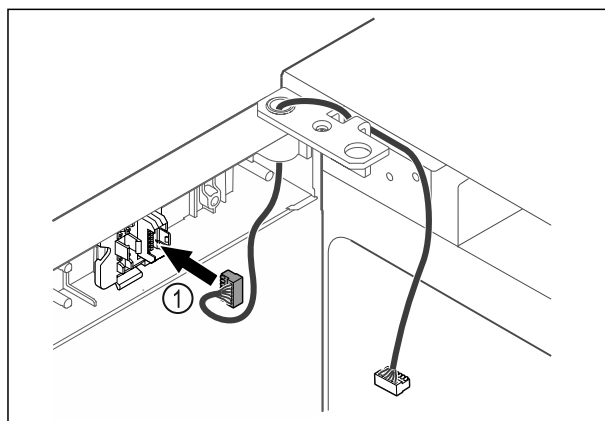

Fig. 46

- ▶ Put the plug Fig. 46 (1) in the plug holder.

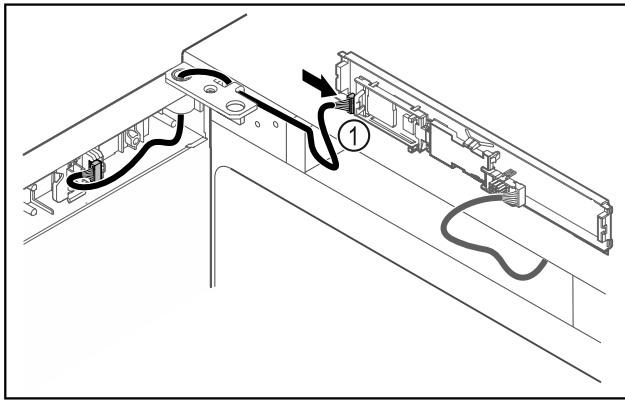

Fig. 47

- ▶ Connect the plug Fig. 47 (1) to the circuit board.

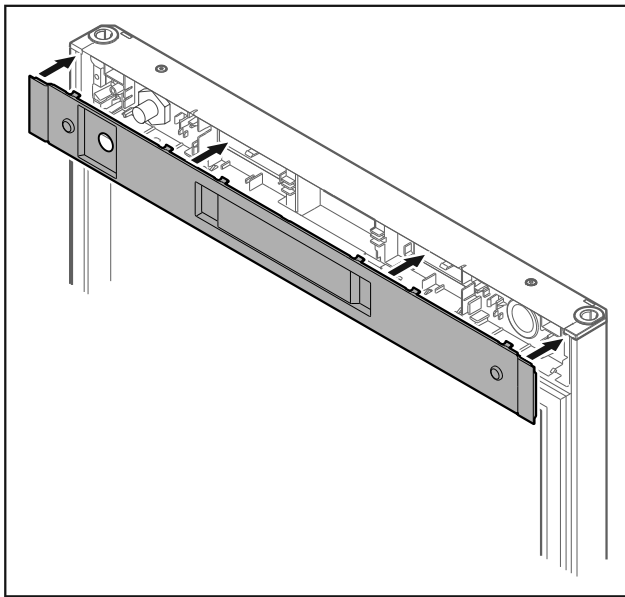

Fig. 48

- ▶ Set the cover back in place.

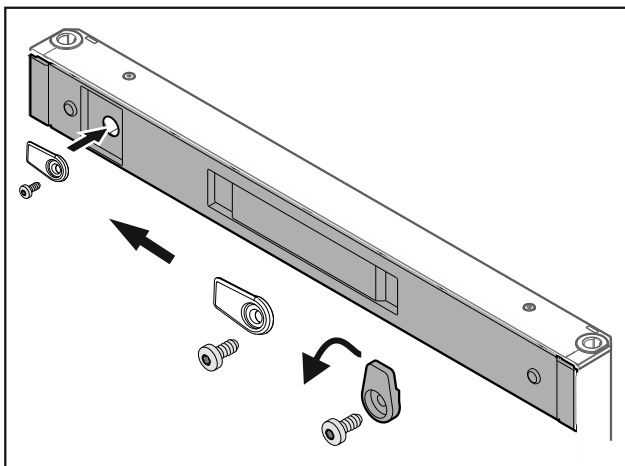

Fig. 49

- ▶ Screw on the door latch.

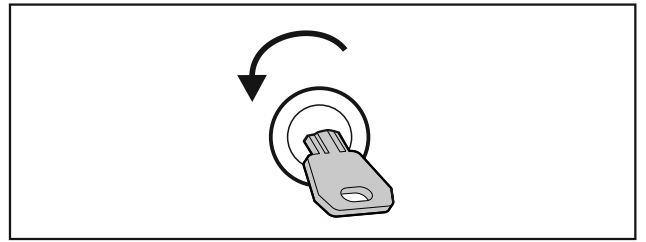

Fig. 50

- ▶ Open the door.

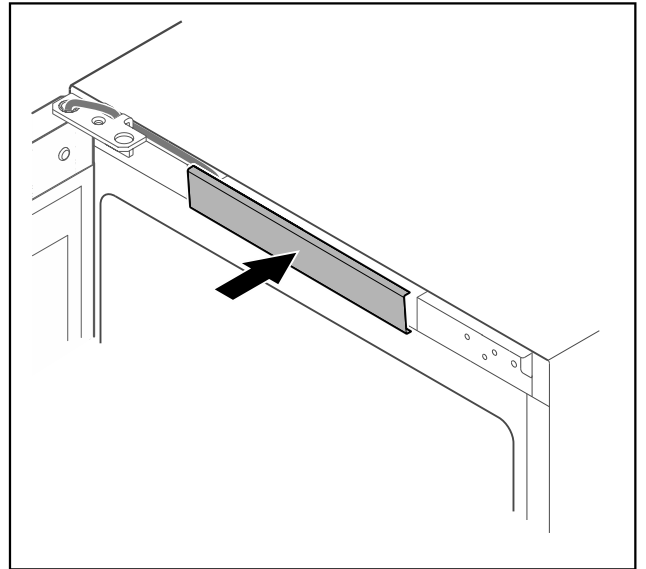

Fig. 51

- ▶ Snap in the middle cover.

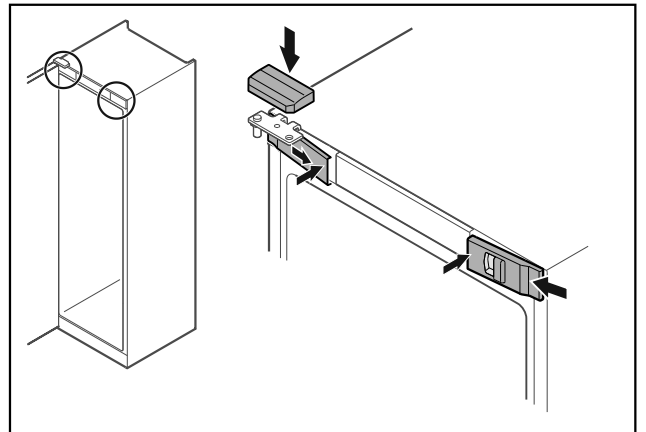

Fig. 52

- ▶ Hook in the front covers Fig. 52 (1) on the side and snap them into place on the inside.
- ▶ Snap on the top cover Fig. 52 (2) from above.
- ▶ Close the door.
- ▷ The door has now been reversed.

3.14 Aligning the door

If the door is not straight, you can adjust it on the lower hinge.

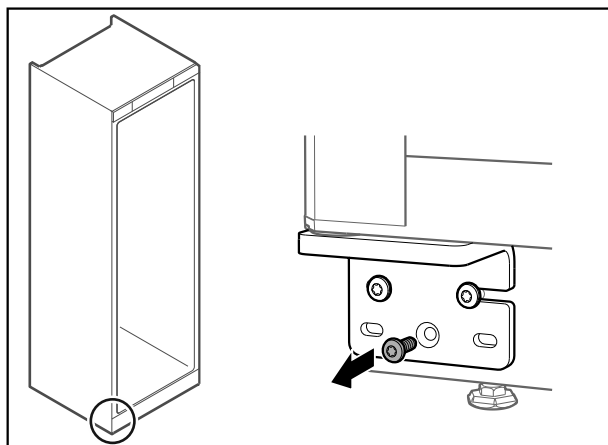

Fig. 53

- ▶ Remove the middle screw on the lower hinge.

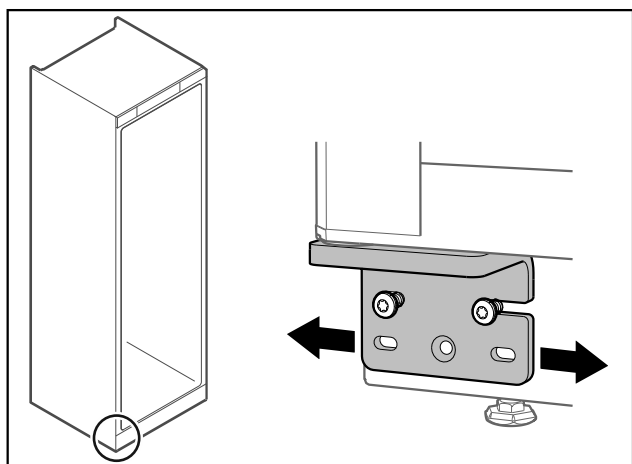

Fig. 54

- ▶ Slightly undo both screws and move the door with the hinge to the left or right.
- ▶ Fully tighten the screws (the middle screw is no longer needed).
- ▷ The door is now straight.

3.15 Connecting the appliance

! WARNING

Danger of fire due to incorrect connection!
Burns.

Damage to the appliance.

- ▶ Do not use an extension cord.
- ▶ Do not use a multipoint connector strip.

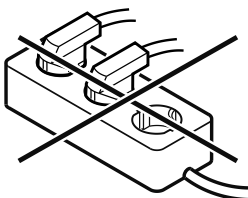

NOTICE

Danger of damage to incorrect connection!
Damage to the appliance.

- ▶ Do not connect the appliance to a stand-alone inverter, e.g. solar power systems and petrol generators.

Note

Only use the supplied power cable.

Make sure that the following requirements are fulfilled:

- The appliance is operated using **alternating current** only.
- The permitted voltage and frequency are printed on the type plate. The type plate position can be seen in the appliance overview chapter. (see 1.2 Overview of appliance and equipment)
- The socket is grounded and fused in accordance with regulations.
- The tripping current for the fuse is between 10 A and 16 A.
- The socket is easily accessible.
- ▶ Check the electrical connection.
- ▶ Insert the appliance plug on the rear side of the appliance. Ensure that it engages correctly.
- ▶ Connect the power plug to the power supply.
- ▷ The display switches to the standby symbol.

3.16 Switching on the appliance (first use)

Make sure that the following requirements are fulfilled:

- Appliance is set up and connected.
- All adhesive strips, adhesive and protective films and transport locks are removed from inside and outside the appliance.

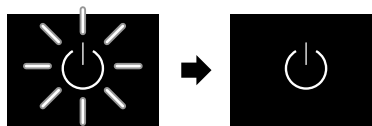

Fig. 55 Example illustration

The standby symbol flashes until the startup process is complete.

The standby symbol is shown in the display.

If the appliance has been supplied with factory settings, the screen language and the date/time first need to be set when using the appliance for the first time.

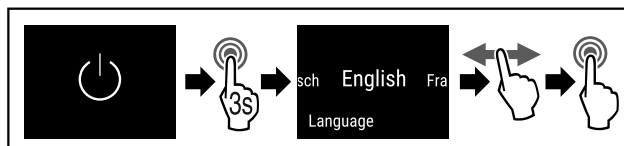

Fig. 56

- ▶ Carry out action steps according to the illustration.
- ▷ Language is set.

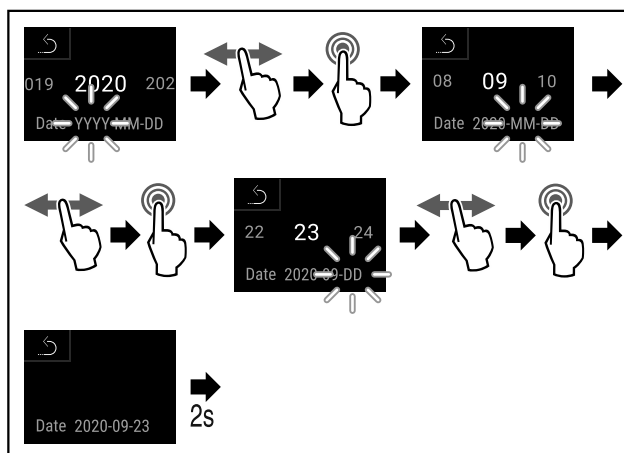

Fig. 57

- ▶ Carry out action steps according to the illustration.
- ▷ Date is set.

Storage

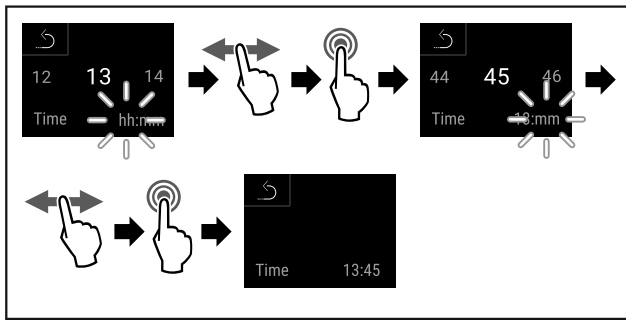

Fig. 58

- ▶ Carry out action steps according to the illustration.
- ▷ Time is set.

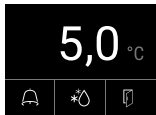

Fig. 59 Status display

- ▷ The appliance is ready for use once the temperature appears in the display.
- ▷ The temperature display flashes until the set temperature is reached.

4 Storage

4.1 Information regarding storing items

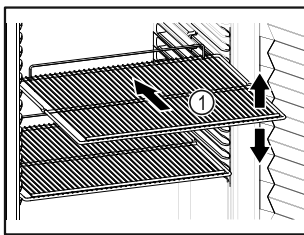

Fig. 60 Example illustration

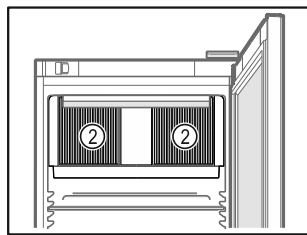



Fig. 61

When stocking items, observe the following:

- If there are adjustable shelves Fig. 60 (1), position them as required.
 - Observe maximum load weight. (see 8.1 Technical data)
 - Do not stock appliance until the storage temperature has been reached (maintain cold chain).
 - Ventilation slots Fig. 61 (2) for recirculation fan in the interior must be kept clear.
 - Refrigerated goods must not touch the rear wall.
 - Do not store refrigerated goods beyond the rear stop of the support grates.
 - Keep liquids in closed containers.
 - Leave space when storing items for refrigeration to ensure adequate air circulation.
 - Do not stack refrigerated products above the indicated height. 
- This is important for free air circulation and even temperature distribution in the interior.

5 Use

5.1 Control and display elements

The display provides a quick overview of the current appliance status, the temperature setting, the status of functions and settings as well as alarm and error messages.

It is operated by swiping or pressing the color touch display directly.

Functions can be activated or deactivated and settings values can be changed.

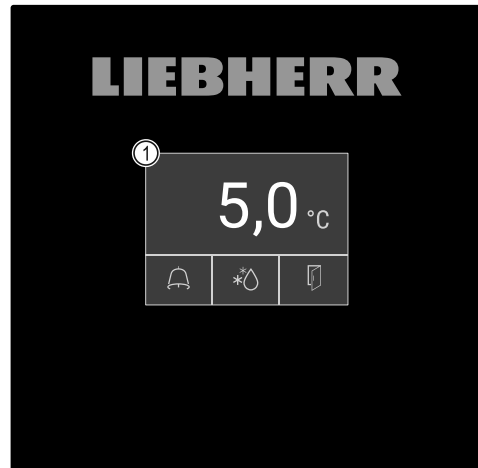

Fig. 62 Color touch display

(1) Status display

5.1.1 Status display



Fig. 63 Status display

(1) Actual temperature
(2) Alarm status

(3) Defrosting status
(4) Door opening status



The status display is the home display.

It displays the temperature in the center and three symbols in the lower area. The status display may show a further range of display symbols.

You navigate from the status display to the functions and settings. (see 5.2 Navigation)

5.1.2 Display symbols

The display symbols provide information about the current status of the appliance.

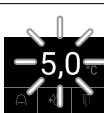
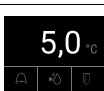
Symbol	Appliance status
	Standby symbol Appliance is switched off.
	Standby (flashing) symbol Appliance is starting up.
	Temperature (flashing) Target temperature not yet reached. Appliance cooling to set temperature.
	Temperature display Displays the current interior temperature

Symbol	Appliance status
	D in the display Appliance is in Demo-Mode.
	Maintenance display (yellow) The set time interval has expired.
	Full data memory (yellow) The data memory (999 hours) is full. From now, the oldest data will be overwritten.
	Full alarm memory (yellow) The alarm memory is full. Delete individual alarms or entire memory.
	Error symbol (red) Appliance is in error state.
	Back arrow Leads to higher-level menu.
	Background (blue) Active setting or active function
	Bar (increasing) Press for 3 seconds to activate setting.
	Bar (decreasing) Press for 3 seconds to deactivate setting.

Status display symbols

The additional symbols at the bottom edge of the status display enable quick access to alarm information and details of the appliance state.

Symbol	Appliance status
	Alarm symbol (gray) Alarm archive is empty. A brief tap opens the alarm archive.
	Alarm symbol (white) There are confirmed alarms in the alarm archive. A brief tap opens the alarm archive.
	Alarm symbol (red) There are still unconfirmed alarms in the alarm archive. A brief tap opens the alarm archive.
	Alarm symbol (red, flashing) There is an active alarm in the archive. A brief tap opens the alarm archive.
	Defrosting symbol (gray) No active defrosting process.

Symbol	Appliance status
	Defrosting symbol (white, flashing) Manual defrosting process active. A brief tap opens the manual defrosting. (see 5.3.20 Defrosting)
	Defrosting symbol (white) Automatic defrosting process active. Function cannot be aborted.
	Door symbol (gray) The door is closed.
	Door symbol (white) The door is open.
	Door symbol (red, flashing) The door has been open for a prolonged period of time; the relevant warning message has been acknowledged. The symbol flashes until the door is closed.

Additional status display symbols

5.1.3 Acoustic signals

A signal sounds in the following cases:

- If a function or a value is confirmed.
- If a function or a value can neither be activated nor deactivated.
- As soon as a fault occurs.
- If there is an alarm message.

The alarms can be switched on and off in the customer menu.

5.2 Navigation

Navigate in the menu to access the individual functions. Operation using the touch display via swiping and tapping.

5.2.1 Navigation with the touch display

Navigation	Description
	Press briefly Activates / deactivates function. Confirms selection. Opens submenu.
	Long press (3 seconds) Activates / deactivates function. Confirms selection. Resets appliance / values. Switches appliance on / off.
	Swipe right or left Navigates within the menu.
	Brief tap "Back" symbol Goes back one level.

Use

Navigation	Description
	Long press (3 seconds) "Back" symbol Returns to the status display.

5.2.2 Settings menu

You can access additional appliance functions via the Service menu.

Opening the Settings menu

- ▶ Swipe left or right until corresponding function is displayed.



Fig. 64

- ▶ Carry out steps according to the illustration.

-or-

- ▶ Enter access protection PIN code for the Settings menu. (see 5.3.6 Settings menu access protection)

- ▷ The Settings menu opens.

Settings menu access protection

(see 5.3.6 Settings menu access protection)

5.2.3 Customer menu

The Customer menu is protected by the code **151**. You can access additional appliance functions.

Opening the Customer menu

- ▶ Swipe left or right until corresponding function is displayed.

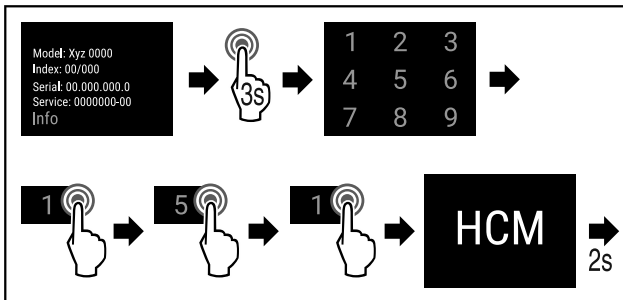

Fig. 65

- ▶ Carry out steps according to the illustration.

- ▷ The customer menu is opened.

5.2.4 General rules

















The following general rules apply in addition to the gestures available:





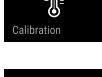







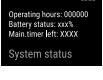

- Once a value has been selected, the selection is displayed for 2 seconds. The display then jumps back one level.
- After 10 seconds without interaction, return to the status display (excluding the customer menu).
- If a selection is confirmed in a submenu, the display switches back to the menu.
- Activated functions and selected values are highlighted **blue**.
- Error/alarm/warning messages are highlighted **red**.
- Instructions/reminders are highlighted **yellow**.

- Long press to activate functions: increasing bar is displayed on the screen.
- Long press to deactivate functions: decreasing bar is displayed on the screen.

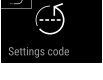
5.3 Appliance functions

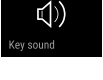
5.3.1 Overview of functions

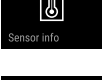
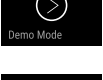
	Switch appliance on and off
	Reset logging
	Manually starts automatic defrosting
	Settings Access to this function can be blocked using a PIN code. (see 5.3.6 Settings menu access protection)
	Info
	Temperature setting
	Temperature alarm
	Door alarm
	Light alarm*
	Alarm simulation
	Alarm relay
	Alarm log
	Sensor calibration
	Maintenance interval reminder
	Lighting
	Language

	Date/time
	Temperature unit
	Screen brightness
	Data download
	LAN *
	WiFi *
	System status*
	Software
	Settings lock PIN code change
	Activate/deactivate settings lock
	Alarm sounds
	Button sounds
	Door lighting
	Defrost information
	Sensor Info
	DemoMode
	Factory reset

Switching on appliance

Without activated DemoMode:

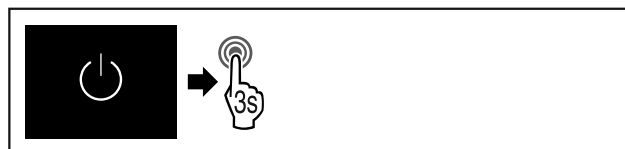

Fig. 66

- ▶ Complete the steps.

With activated DemoMode:

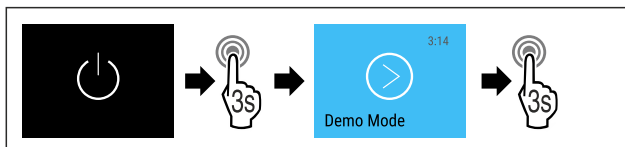

Fig. 67

- ▶ Complete the steps.

Note

Deactivate DemoMode before countdown finishes.

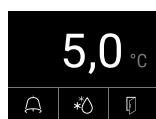

Fig. 68 Status display

- ▷ The temperature appears in the display.

Switching off appliance

- ▶ Call up the settings menu. (see 5.2 Navigation)
- ▶ Swipe left or right on the display until the corresponding function is displayed.

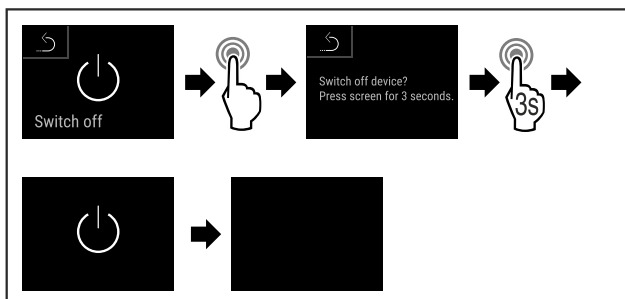

Fig. 69

- ▶ Complete the steps.
- ▷ Standby symbol is shown in the display.
- ▷ Display switches off after approximately 10 minutes.

5.3.3 Temperature



The temperature depends on the following factors:

- How often the door is opened
- How long the door is open for
- The room temperature of the installation site
- The type, temperature and amount of refrigerated items

Note

The temperature may differ from the temperature displayed in some areas of the interior.

At the correct temperature, refrigerated items will keep for longer. This avoids disposing of food unnecessarily.

5.3.2 Switching appliance on and off



This function makes it possible to switch the entire appliance on and off.

Setting the temperature

The following steps describe how to increase the temperature, e.g. from 12.1 °C to 15.5 °C.

- ▶ Call up settings menu. (see 5.2 Navigation)
- ▶ Swipe left or right until corresponding function is displayed.

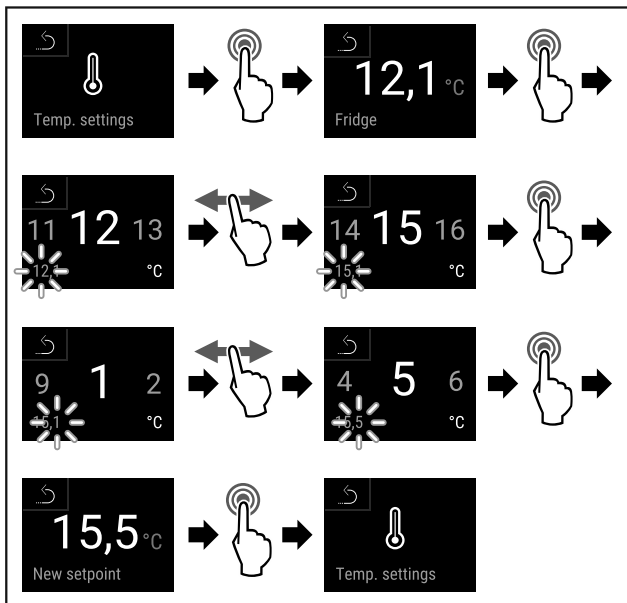

Fig. 70

- ▶ Complete steps (see Fig. 70).
- ▷ Temperature is set.



5.3.4 Temperature recording

The appliance displays the minimum and maximum temperatures of the interior via this function. The recording of these temperatures starts automatically after the appliance is switched on; they are recorded at one minute intervals. A note indicating that the data memory is full is displayed after 999 hours (approx. 40 days). The temperature recording should then be reset.

Note

The entire temperature history as well as alarm and service messages are also recorded independently of this function. This data can be exported and backed up on a USB storage medium. (see 5.3.21 Data download / Datalogging)

If there is an additional product sensor installed on the appliance, there is the option of selecting this sensor to display the minimum and maximum temperatures. (see 5.3.22 Sensor calibration)

Note

The temperature recording should be reset once **after reaching the set temperature** when the appliance is commissioned. (see Resetting temperature recording) This ensures that the value for the maximum temperature is a meaningful value.

Displaying temperature recording

The temperature recording displays the length of the recording and the minimum and maximum temperatures measured during this period of time.

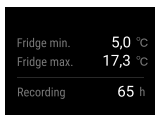

Fig. 71

- ▶ Swipe left or right until corresponding function is displayed.
- ▷ Status screen with the temperature recordings is displayed.

Resetting temperature recording

The displayed minimum and maximum temperatures can be reset at any time. This deletes the displayed values and the recording interval starts again.

- ▶ Swipe left or right until corresponding function is displayed.

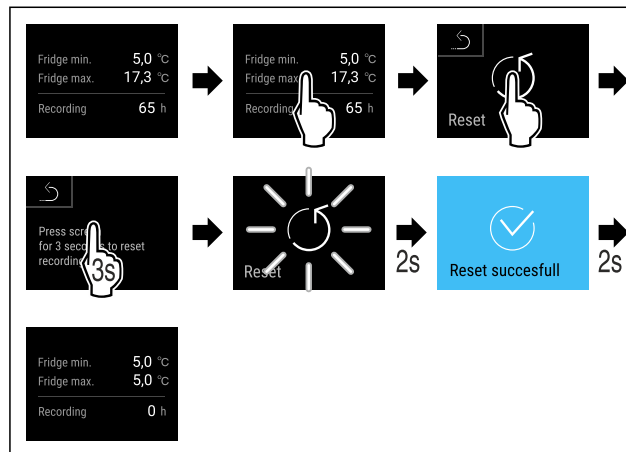

Fig. 72

- ▶ Complete the steps.
- ▷ Temperature recording is reset.



5.3.5 Lighting

The appliance is equipped with interior lighting.

You can keep the interior lighting on continuously. (see Switching on lighting*)

When you open the appliance door, the interior lighting switches on. You can also deactivate this function. (see Switching off the lighting when opening the door)

Switching on lighting*

- ▶ Call up settings menu. (see 5.2 Navigation)
- ▶ Swipe left or right until corresponding function is displayed.

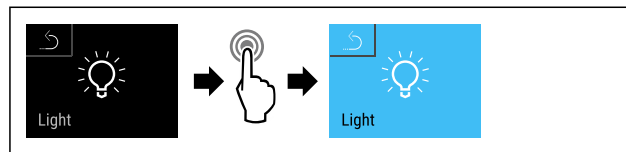

Fig. 73

- ▶ Complete steps (see Fig. 73).
- ▷ Lighting is switched on.

Switching off lighting*

- ▶ Call up settings menu. (see 5.2 Navigation)
- ▶ Swipe left or right until corresponding function is displayed.

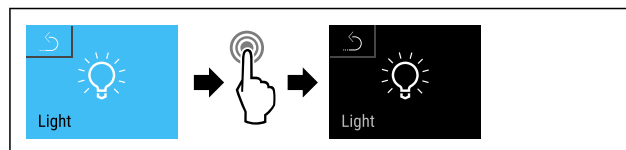

Fig. 74

- ▶ Complete steps (see Fig. 74).
- ▷ Lighting is switched off.

Switching off the lighting when opening the door

- ▶ Open the customer menu. (see 5.2 Navigation)
- ▶ Swipe left or right until corresponding function is displayed.

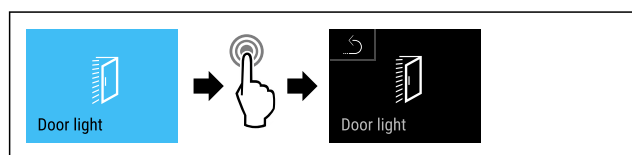

Fig. 75

- ▶ Complete the steps (see Fig. 75).
- ▷ The lighting is switched off when the door is opened.

Switching on the lighting when opening the door

- ▶ Open the customer menu. (see 5.2 Navigation)
- ▶ Swipe left or right until corresponding function is displayed.

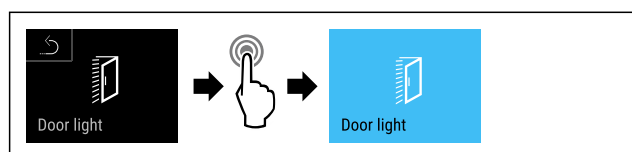

Fig. 76

- ▶ Complete the steps (see Fig. 76).
- ▷ The lighting is switched on when the door is opened.

5.3.6 Settings menu access protection



This function enables the settings menu access protection via a four-digit PIN code.

Application:

- Prevent settings and functions being changed unintentionally.
- Prevent the appliance from being switched off unintentionally.
- Prevent the temperature from being adjusted unintentionally.

Activating the settings menu access protection

Note

- ▶ In the following example, the factory-set PIN code: **1 1 1 1** is used.

- ▶ Open the customer menu. (see 5.2 Navigation)
- ▶ Swipe left or right until corresponding function is displayed.

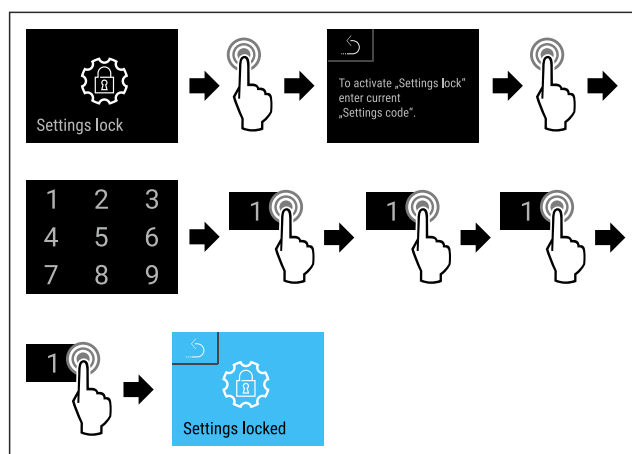

Fig. 77

- ▶ Complete steps (see Fig. 77).
- ▷ Settings menu access protection is activated.

Changing the access protection PIN code for the settings menu

(see 5.3.7 Access codes)

Deactivating the settings menu access protection

Note

- ▶ In the following example, the factory-set PIN code: **1 1 1 1** is used.

- ▶ Open the customer menu. (see 5.2 Navigation)
- ▶ Swipe left or right until corresponding function is displayed.

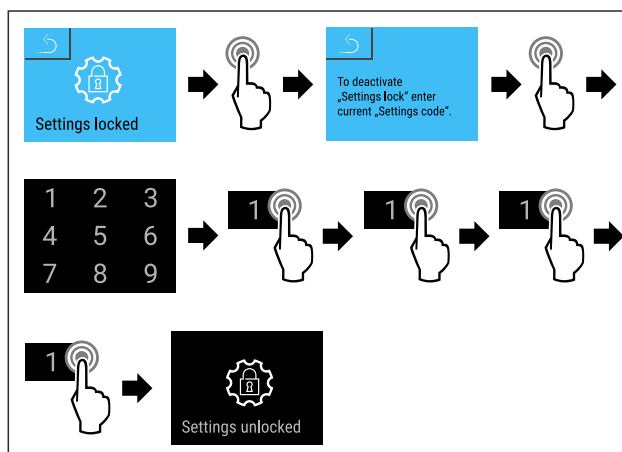

Fig. 78

- ▶ Complete steps (see Fig. 78).
- ▷ Settings menu access protection is deactivated.

Opening protected settings menu

If the settings menu access protection is active, it is necessary to enter the PIN code to open the settings menu.

The settings menu remains unlocked for 20 minutes after entering the correct PIN code.

Note

- ▶ In the following example, the factory-set PIN code: **1 1 1 1** is used.

Access protection for the settings menu must be active.

- ▶ Swipe left or right until corresponding function is displayed.

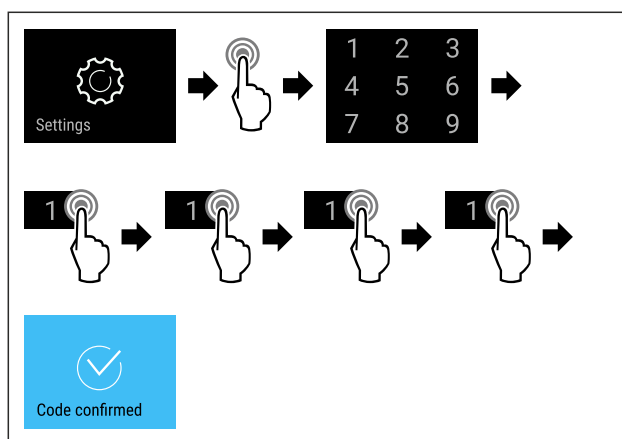

Fig. 79

- ▶ Complete the steps (see Fig. 79).
- ▷ PIN code is correct: settings menu opens.

5.3.7 Access codes

Various settings are possible.

Use

Application:

- Changing the settings code.
- Resetting the settings code.



Settings menu access protection

Changing the settings code

This setting allows the settings code for settings menu access protection to be changed.

The setting is made in 3 stages:

- Entering the old settings code
- Entering the new settings code
- Confirming the new settings code

Note

- ▶ In the following example, the default factory-set settings code **1 1 1 1** is changed.
- ▶ The new settings code is: **2 3 4 5**

- ▶ Open the customer menu. (see 5.2 Navigation)
The settings menu access protection must be active. (see 5.3.6 Settings menu access protection)
- ▶ Swipe left or right until corresponding function is displayed.

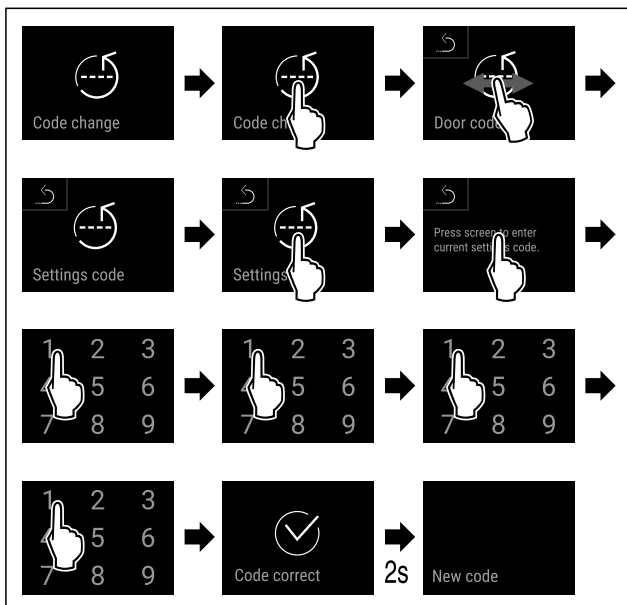

Fig. 80

- ▶ Carry out action steps according to the illustration.
- ▶ Entry of the old settings code successful.

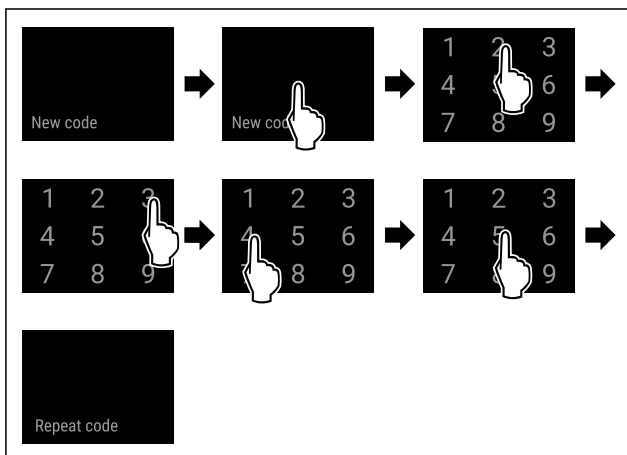

Fig. 81

- ▶ Carry out action steps according to the illustration.
- ▶ Entry of the new settings code successful.

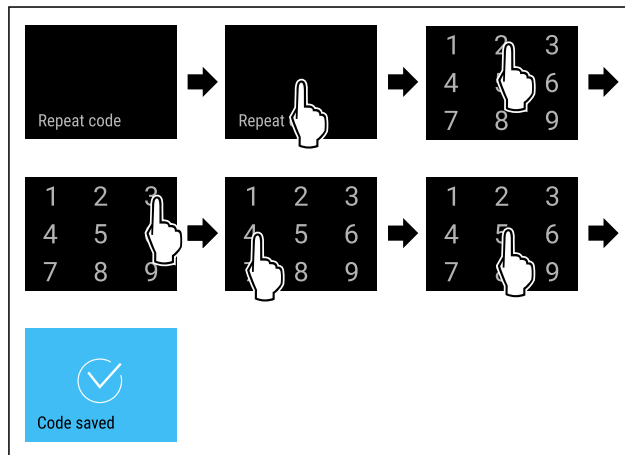

Fig. 82

- ▶ Carry out action steps according to the illustration.
- ▶ Confirmation of the new settings code successful.
- ▶ The settings code has been changed.

Resetting the settings code

The settings code for the settings menu access protection has been forgotten or is not known.

- ▶ Reset the appliance to factory settings (see 5.3.30 Factory reset).
- ▶ The appliance is reset to the original settings.
- ▶ The factory-set settings code is: **1 1 1 1**

5.3.8 Maintenance interval reminder



Setting for the time interval after which a maintenance reminder is issued.

The following values can be set:

- 7 days
- 14 days
- 30 days
- 60 days
- 90 days
- 180 days
- 360 days
- 720 days
- 1080 days
- Off

Setting maintenance interval reminder

The following steps describe how the maintenance interval is set.

- ▶ Call up settings menu. (see 5.2 Navigation)
- ▶ Swipe left or right until corresponding function is displayed.

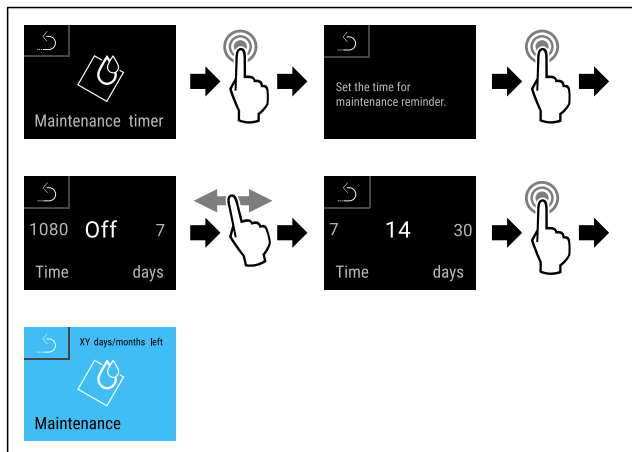

Fig. 83

- ▶ Complete steps (see Fig. 83).
- ▷ The time interval, after which the maintenance reminder is issued, is set.
- ▷ The remaining time is displayed.

5.3.9 Language



This setting allows the display language to be set.

Setting the language

- ▶ Call up settings menu. (see 5.2 Navigation)
- ▶ Swipe left or right until corresponding function is displayed.

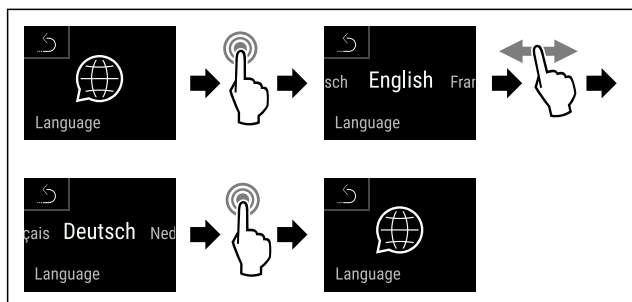

Fig. 84

- ▶ Complete steps (see Fig. 84).
- ▷ The selected language is set.

5.3.10 Date and time



This setting makes it possible to set the date and time.

Setting date and time

- ▶ Call up settings menu. (see 5.2 Navigation)
- ▶ Swipe left or right until corresponding function is displayed.

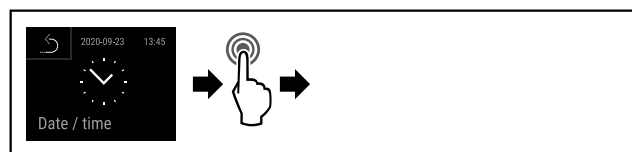

Fig. 85

- ▶ Complete steps (see Fig. 85).

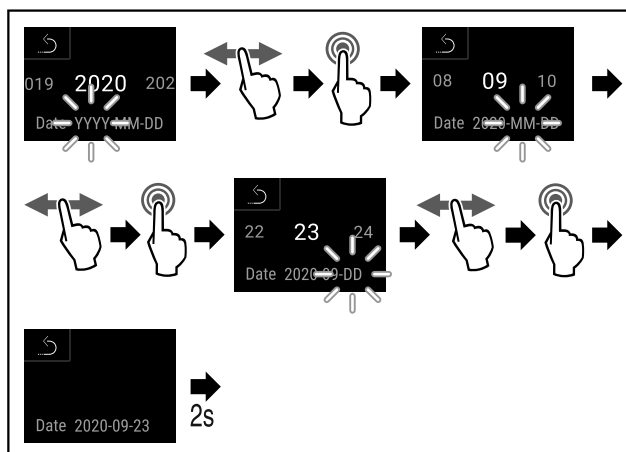

Fig. 86

- ▶ Complete steps (see Fig. 86).
- ▷ Date has been set.

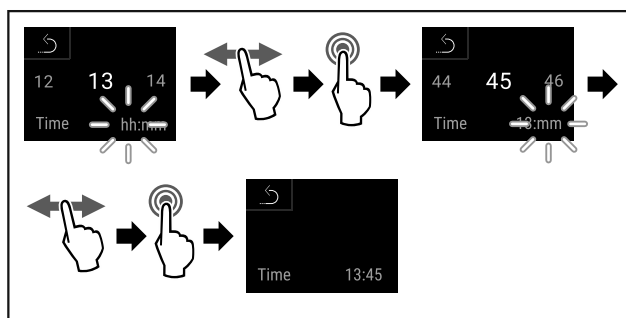

Fig. 87

- ▶ Complete steps (see Fig. 87).
- ▷ Time has been set.

5.3.11 Temperature unit



This setting allows the temperature unit to be changed between degrees Celsius and Fahrenheit.

Setting the temperature unit

The example shows how to change the temperature unit from degrees Celsius to Fahrenheit.

- ▶ Call up settings menu. (see 5.2 Navigation)
- ▶ Swipe left or right until corresponding function is displayed.

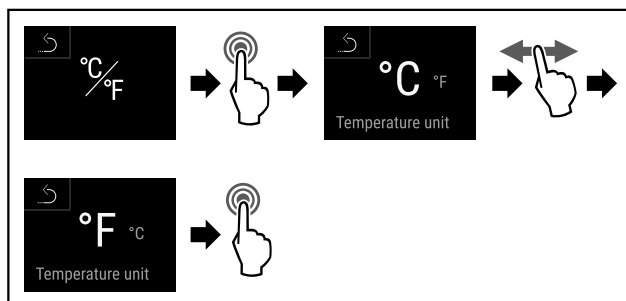

Fig. 88

- ▶ Complete steps (see Fig. 88).
- ▷ The temperature unit is set as Fahrenheit.

5.3.12 Display brightness



This setting allows the display brightness to be adjusted incrementally.

Use

The following brightness values can be set:

- 40%
- 60%
- 80%
- 100% (default)

Setting the display brightness

The following steps describe how to reduce the display brightness, e.g. from 100 % to 40 %.

- ▶ Call up settings menu. (see 5.2 Navigation)
- ▶ Tap navigation arrow repeatedly until corresponding function is displayed.

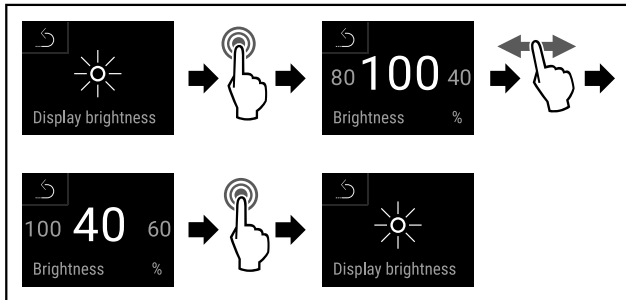

Fig. 89

- ▶ Carry out steps according to the illustration.
- ▷ Display brightness changes accordingly.



5.3.13 Alarm Sound

This function enables all alarm sounds, such as the door alarm, to be switched on and off.

Activating Alarm Sound

- ▶ Open the customer menu. (see 5.2 Navigation)
- ▶ Swipe left or right until corresponding function is displayed.

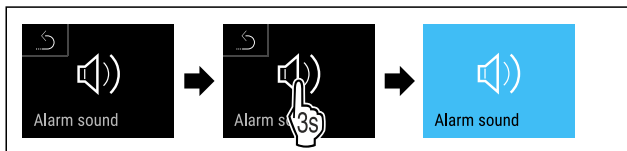

Fig. 90

- ▶ Complete steps (see Fig. 90).
- ▷ Alarm Sound is activated.

Deactivating Alarm Sound

- ▶ Open the customer menu. (see 5.2 Navigation)
- ▶ Swipe left or right until corresponding function is displayed.

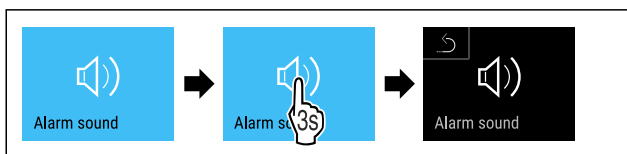

Fig. 91

- ▶ Complete steps (see Fig. 91).
- ▷ Alarm Sound is deactivated.



5.3.14 Key Sound

This function makes it possible to switch all button sounds, confirmation sounds, and the startup sound on and off.

Activating Key Sound

- ▶ Open the customer menu. (see 5.2 Navigation)
- ▶ Swipe left or right on the display until the corresponding function is displayed.

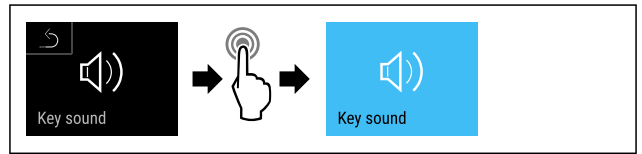

Fig. 92

- ▶ Carry out action steps according to the illustration.
- ▷ Key Sound is activated.

Deactivating Key Sound

- ▶ Open the customer menu. (see 5.2 Navigation)

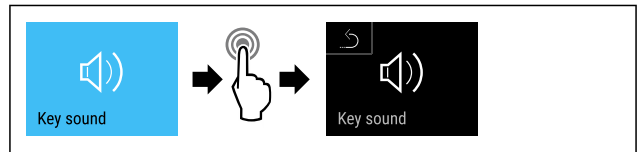

Fig. 93

- ▶ Carry out action steps according to the illustration.
- ▷ Key Sound is deactivated.



5.3.15 WiFi connection

Note

Liebherr SmartMonitoring Dashboard is not available in all countries. Check availability via the QR code by entering your model.

Note

Use of the Liebherr SmartMonitoring Dashboard at <https://smartmonitoring.liebherr.com> requires installation of a SmartModule and a commercial MyLiebherr account. When commissioning online you can register using your login data, or register again and create a company account.

This setting establishes a wireless connection between the appliance and the internet. The connection is controlled via the SmartModule. The appliance can be integrated via the browser-based Liebherr SmartMonitoring Dashboard and advanced options and customized methods relating to control, administration and monitoring can be used.

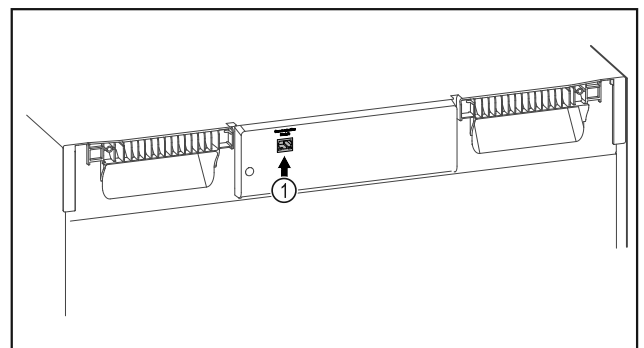

Fig. 94

Make sure that the following requirements are fulfilled:

- SmartModule Fig. 94 (1) is in use.

Establishing a connection

You commission and set up your SmartModule online via the [Liebherr SmartMonitoring Dashboard](#) on your web-enabled device.



Fig. 95

- ▶ Open [Liebherr SmartMonitoring Dashboard](#). (see Fig. 95)

On the fridge or freezer:

- ▶ Swipe left or right until corresponding function is displayed.

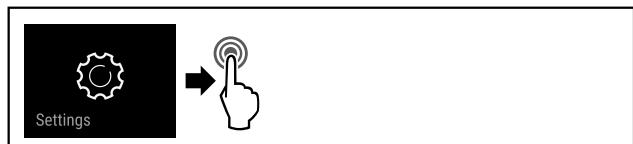

Fig. 96

- ▶ Carry out action steps according to the illustration.

Note

The settings menu access protection is activated. (see 5.3.6 Settings menu access protection)

- ▶ Enter the chosen PIN code. The settings menu opens.

- ▶ Swipe left or right until corresponding function is displayed.

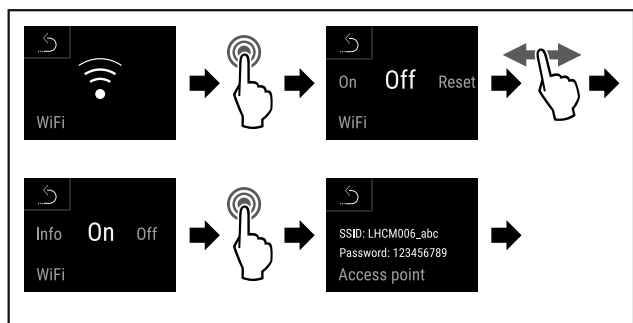

Fig. 97

- ▶ Carry out action steps according to the illustration.
- ▶ Continue the set-up procedure on your web-enabled device: [Liebherr SmartMonitoring Dashboard](#)

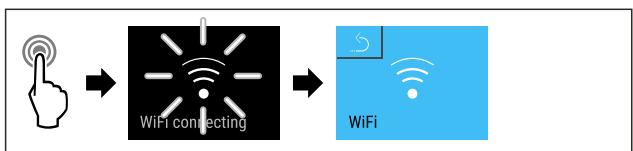

Fig. 98

- ▶ Carry out action steps according to the illustration.
- ▷ Connection is established: WiFi connecting appears. The symbol flashes.
- ▶ Follow the [Liebherr SmartMonitoring Dashboard](#) instructions.
- ▷ Connection is established.

Disconnecting

- ▶ Swipe left or right until corresponding function is displayed.



Fig. 99

- ▶ Carry out action steps according to the illustration.

Note

The settings menu access protection is activated. (see 5.3.6 Settings menu access protection)

- ▶ Enter the chosen PIN code. The settings menu opens.

- ▶ Swipe left or right until corresponding function is displayed.

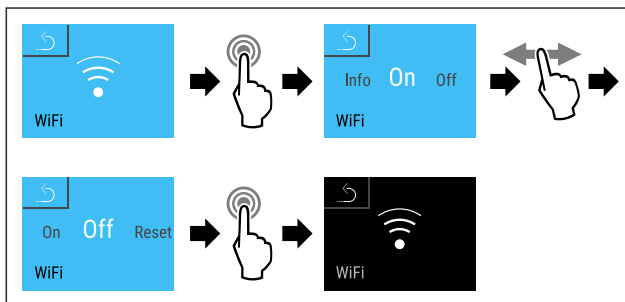

Fig. 100

- ▶ Carry out action steps according to the illustration.
- ▷ There is no connection.

Resetting connection

- ▶ Swipe left or right until corresponding function is displayed.



Fig. 101

- ▶ Carry out action steps according to the illustration.

Note

The settings menu access protection is activated. (see 5.3.6 Settings menu access protection)

- ▶ Enter the chosen PIN code. The settings menu opens.

- ▶ Swipe left or right until corresponding function is displayed.

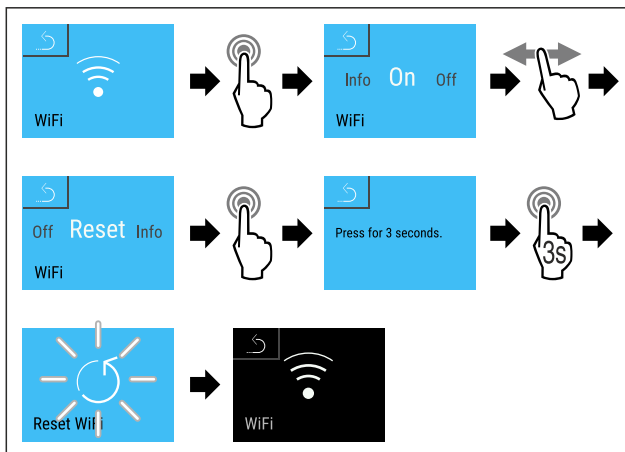

Fig. 102

- ▶ Carry out action steps according to the illustration.
- ▷ The WiFi settings are restored to the factory settings.



5.3.16 LAN connection

Note

Liebherr SmartMonitoring Dashboard is not available in all countries. Check availability via the QR code by entering your model.

Note

Use of the Liebherr SmartMonitoring Dashboard at <https://smartmonitoring.liebherr.com> requires installation of a SmartModule and a commercial MyLiebherr account. When commissioning online you can register using your login data, or register again and create a company account.

This setting establishes a wired connection between the appliance and the internet. The connection is controlled via the SmartModule. The appliance can be integrated via the browser-based [Liebherr SmartMonitoring Dashboard](#) and advanced options and customized methods relating to control, administration and monitoring can be used.

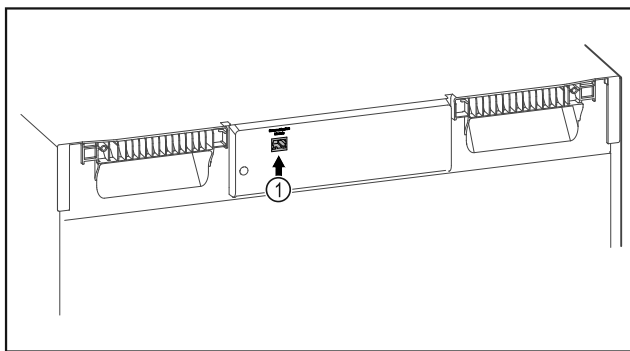

Fig. 103

Make sure that the following requirements are fulfilled:

- SmartModule Fig. 103 (1) is in use.
- A network cable is connected.

Establishing a connection

You commission and set up your SmartModule online via the [Liebherr SmartMonitoring Dashboard](#) on your web-enabled device.



Fig. 104

- ▶ Open [Liebherr SmartMonitoring Dashboard](#). (see Fig. 104)
- On the fridge or freezer:
- ▶ Swipe left or right until corresponding function is displayed.



Fig. 105

- ▶ Carry out action steps according to the illustration.

Note

The settings menu access protection is activated. (see 5.3.6 Settings menu access protection)

- ▶ Enter the chosen PIN code. The settings menu opens.

- ▶ Swipe left or right until corresponding function is displayed.

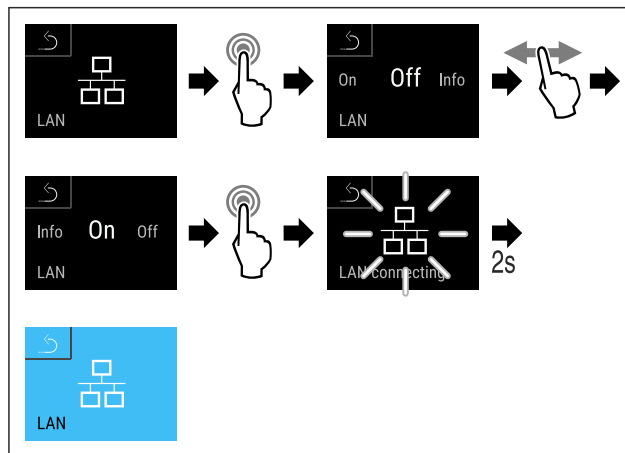

Fig. 106

- ▶ Carry out action steps according to the illustration.
- ▷ Connection is established: LAN connecting appears. The symbol flashes.
- ▶ Follow the [Liebherr SmartMonitoring Dashboard](#) instructions.
- ▷ Connection is established.

Disconnecting

- ▶ Swipe left or right until corresponding function is displayed.

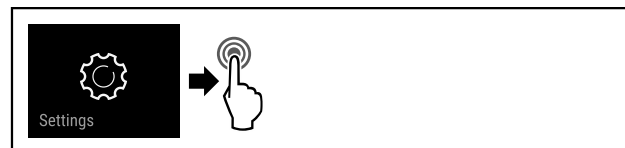

Fig. 107

- ▶ Carry out action steps according to the illustration.

Note

The settings menu access protection is activated. (see 5.3.6 Settings menu access protection)

- ▶ Enter the chosen PIN code. The settings menu opens.

- ▶ Swipe left or right until corresponding function is displayed.

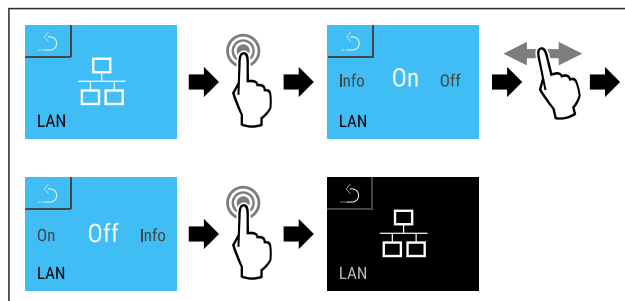

Fig. 108

- ▶ Carry out action steps according to the illustration.
- ▷ There is no connection.

5.3.17 Info



This display shows the model, serial number and service number of the appliance.

Displaying Info

- ▶ Swipe left or right until the corresponding function is displayed.

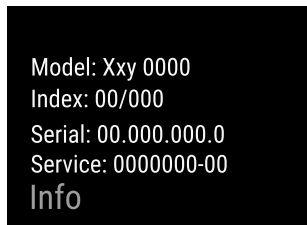
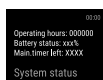

Fig. 109

- ▷ The appliance information appears.

5.3.18 Operating hours



The display shows the appliance operating hours.

Displaying operating hours

- ▶ Open the customer menu .

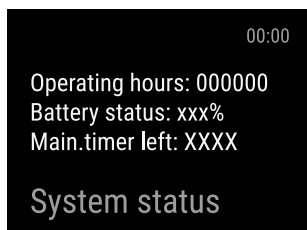

Fig. 110

- ▷ The operating hours appear.

5.3.19 Software



The display shows the software version of the appliance.

Displaying the software version

- ▶ Open the customer menu .
- ▶ Swipe left or right until the corresponding function is displayed.

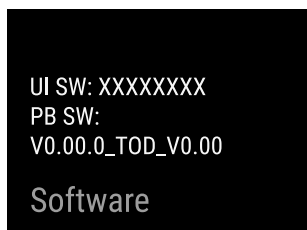

Fig. 111

- ▷ The software version is shown.

5.3.20 Defrosting



The appliance defrosts automatically in normal mode.

Application:

- If there is excessive ice in the interior, the defrosting function can be started manually.

Manually starting automatic defrosting

- ▶ Swipe left or right until corresponding function is displayed.

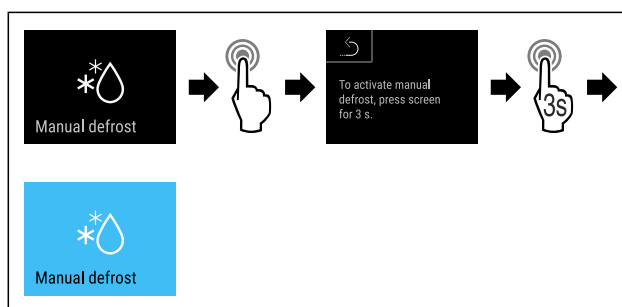

Fig. 112

- ▶ Carry out action steps according to the illustration.
- ▷ Automatic defrosting has been started. The appliance automatically switches back to normal mode once defrosting has finished.

Note

If there is still ice in the interior after starting automatic defrosting several times, defrost the appliance manually. (see 7.2 Defrosting the appliance)

Canceling manually started defrosting

- ▶ Swipe left or right until corresponding function is displayed.

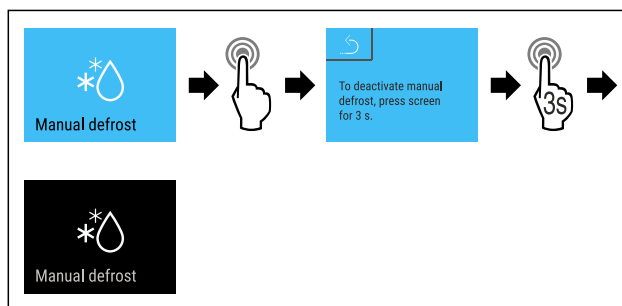

Fig. 113

- ▶ Carry out action steps according to the illustration.
- ▷ Manually started defrosting is canceled. The appliance automatically switches back to normal mode.

Defrosting info



This setting adjusts the display during an automatic defrosting process.

The following display variants are available:

- **Def 1:** “Automatic defrosting process” symbol is displayed in the status screen. The temperature display is not updated and shows the last temperature before the automatic defrosting process was started.
- **Def 2:** “Automatic defrosting process” symbol is displayed in the status screen. The temperature display is updated continuously and shows the actual temperature.
- **Def 3:** The temperature display is not updated and shows the last temperature before the automatic defrosting process was started.
- **Def 4:** The temperature display is updated continuously and shows the actual temperature.



Fig. 114 “Automatic defrosting process” symbol

- ▶ Open the customer menu. (see 5.2 Navigation)

Use

- ▶ Swipe left or right until corresponding function is displayed.

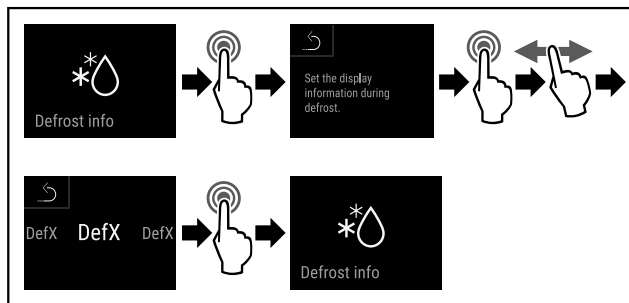

Fig. 115

- ▶ Carry out action steps according to the illustration.
- ▷ The desired display variant has been selected.

5.3.21 Data download / Datalogging



The appliance automatically records the entire temperature history of various sensors as well as alarm and service messages. The recording starts automatically after the appliance is switched on and records at one minute intervals. The data for the past 5 years is stored and can be downloaded onto a USB stick at any time.

The following data sets can be selected for download:

- Temperatures
- Alarms
- Service messages
- All

The selected data sets are stored in unencrypted format as text files over the entire recording period; these files have the extension „.log“.

Data download on USB stick

Note

Only USB memory sticks may be connected to the USB interface. USB hard drives are not detected.

Note

Do not remove the USB storage stick during the download procedure.

Make sure that the following requirements are fulfilled:

- USB 2.0 storage stick, FAT32 formatted.
- USB stick is connected.
- ▶ Call up settings menu. (see 5.2 Navigation)
- ▶ Swipe left or right until corresponding function is displayed.

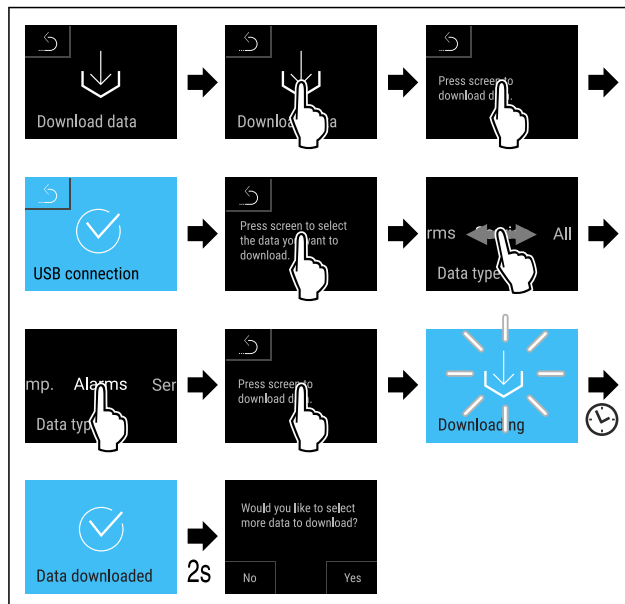

Fig. 116

- ▶ Carry out action steps according to the illustration.
- ▷ Successful data download on USB stick.
- ▷ It is possible to select and download further data sets.

5.3.22 Sensor calibration



The sensor calibration is used to realign differences between the temperature displayed and the actual temperature in the appliance.

Setting range for C sensor (control sensor): +/- 3 Kelvin in 0.1 Kelvin increments.

Setting range for P sensor (product sensor): +/- 9.9 Kelvin in 0.1 Kelvin increments

Calibrating sensor

- ▶ Call up settings menu. (see 5.2 Navigation)
- ▶ Swipe left or right until corresponding function is displayed.

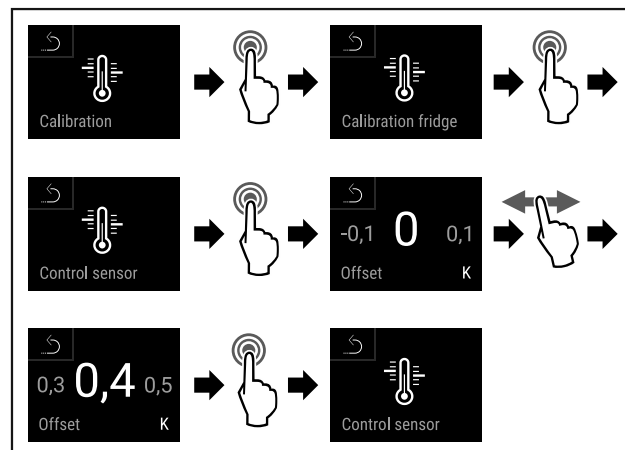

Fig. 117

- ▶ Complete steps (see Fig. 117) .
- ▷ C sensor has been calibrated.

5.3.24 Door alarm



Set the time interval after which the door alarm sounds when the door is opened.

The following values can be set:

- 15 seconds
- 30 seconds
- 60 seconds
- 90 seconds
- 120 seconds
- 150 seconds
- 180 seconds
- Off

Setting the door alarm

The following steps describe how to set the time interval before the door alarm sounds.

- ▶ Call up settings menu. (see 5.2 Navigation)
- ▶ Swipe left or right until corresponding function is displayed.



Fig. 126

- ▶ Carry out steps according to the illustration.
- ▶ Swipe left or right until corresponding function is displayed.

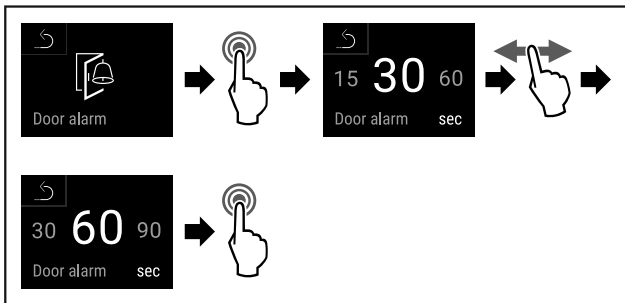

Fig. 127

- ▶ Carry out steps according to the illustration.
- ▷ The door alarm is set.

Deactivating the door alarm

The following steps describe how to deactivate the door alarm.

- ▶ Call up settings menu. (see 5.2 Navigation)
- ▶ Swipe left or right until corresponding function is displayed.



Fig. 128

- ▶ Carry out steps according to the illustration.
- ▶ Swipe left or right until corresponding function is displayed.

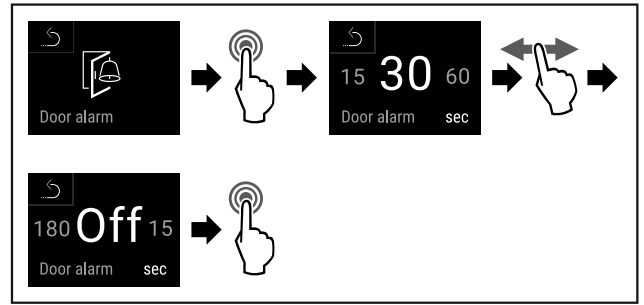
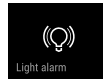

Fig. 129

- ▶ Carry out steps according to the illustration.
- ▷ The door alarm is deactivated.

5.3.25 Light alarm



This setting allows the visual alarm messages in the display to also be emphasized by flashing appliance lighting.

Activating the light alarm

- ▶ Call up settings menu. (see 5.2 Navigation)
- ▶ Swipe left or right until corresponding function is displayed.



Fig. 130

- ▶ Carry out action steps according to the illustration.
- ▶ Swipe left or right until corresponding function is displayed.

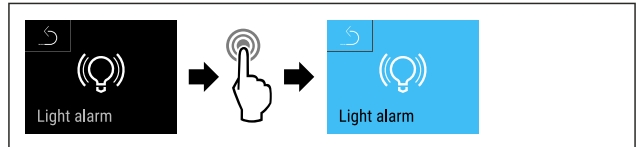

Fig. 131

- ▶ Carry out action steps according to the illustration.
- ▷ The light alarm is activated.

Deactivating the light alarm

- ▶ Call up settings menu. (see 5.2 Navigation)
- ▶ Swipe left or right until corresponding function is displayed.



Fig. 132

- ▶ Carry out action steps according to the illustration.
- ▶ Swipe left or right until corresponding function is displayed.

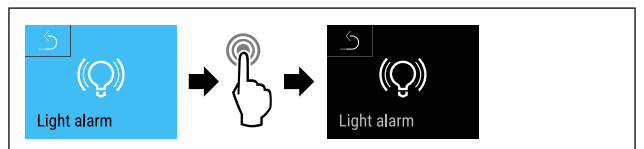

Fig. 133

- ▶ Carry out action steps according to the illustration.
- ▷ The light alarm is deactivated.

5.3.26 Alarm simulation



This setting makes it possible to simulate a change in the appliance temperature to check the function of any safety devices that may be connected.

Starting alarm simulation

- ▶ Call up settings menu. (see 5.2 Navigation)
- ▶ Swipe left or right until corresponding function is displayed.



Fig. 134

- ▶ Carry out action steps according to the illustration.
- ▶ Swipe left or right until corresponding function is displayed.

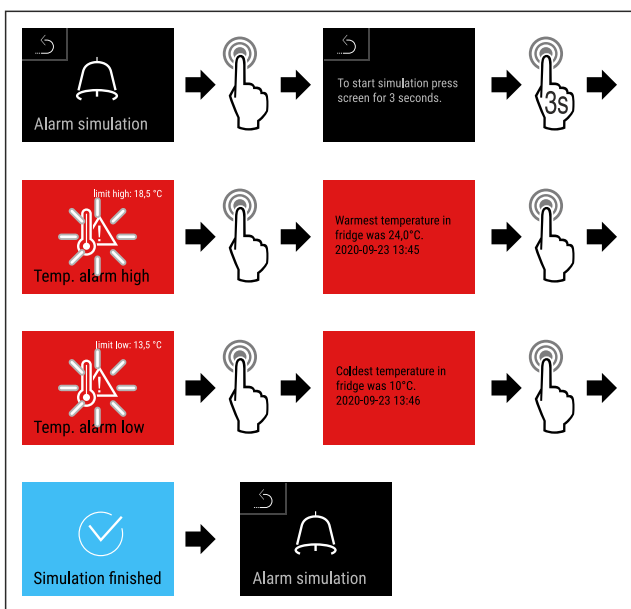
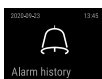

Fig. 135

- ▶ Carry out action steps according to the illustration.
- ▷ The simulation has been performed.
- ▷ Connected safety devices should have triggered.

5.3.27 Alarm log



This setting makes it possible to query and delete the last 10 alarms that have occurred on the device.

The following is displayed:

- Current date and time
- Active alarms (red).
- Past alarms, which have not yet been queried, are shown as **unconfirmed (red)**. Confirmation is given by swiping to the next error.
- Alarms, which have been queried, are shown as **confirmed**.
- Deletion of all alarms (including active and unconfirmed alarms).

Displaying alarm log and deleting an alarm

- ▶ Swipe left or right until corresponding function is displayed.

-or-

- ▶ Via the display symbol at the bottom edge of the status display.

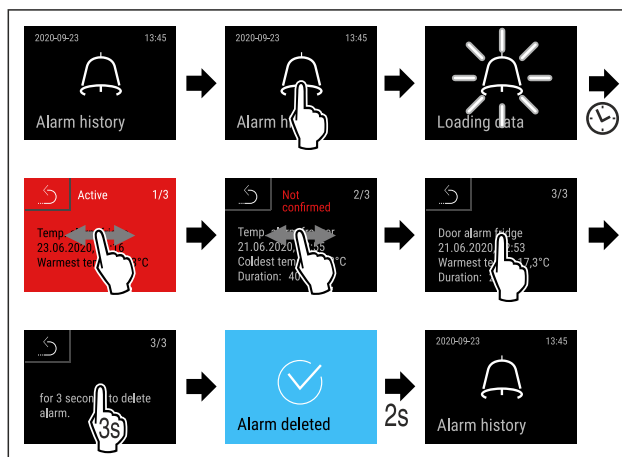

Fig. 136

- ▶ Complete steps (see Fig. 136).
- ▷ The querying and deletion of an alarm has been performed.

Displaying alarm log and deleting all alarms

- ▶ Swipe left or right until corresponding function is displayed.

-or-

- ▶ Via the display symbol at the bottom edge of the status display.

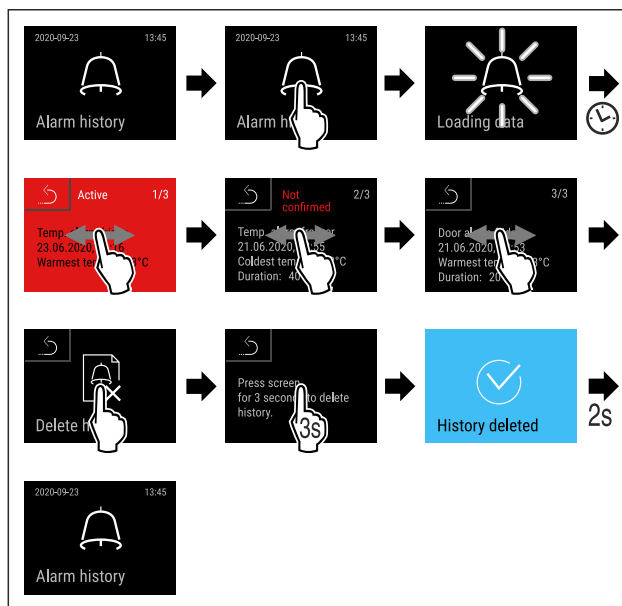

Fig. 137

- ▶ Complete steps (see Fig. 137).
- ▷ The querying and deletion of all alarms has been performed.

5.3.28 Alarm relay



This setting makes it possible to relay one or more alarms to an external alarm receiver connected to the appliance.

The following settings can be selected:

- Alarm type:
 - Door alarm
 - Temperature alarm
 - Door alarm and temperature alarm
 - All

Use

- Confirm:
 - **Yes:** The alarm is terminated at the appliance and the externally connected receiver.
 - **No:** The alarm is acknowledged at the appliance and remains active at the receiver until the error is rectified.
- Update (only visible if "Yes" is selected when confirming):
 - **Yes:** Alarm repeats.
 - Temperature alarm** depending on the set time (see 5.3.23 Temperature alarm) (If the alarm delay time is set to "0", the alarm relay will not repeat the alarm.)
 - Door alarm** after 1 or 4 minutes * (see 5.3.24 Door alarm)
 - **No:** Alarm is continuously acknowledged.

Activating alarm relay

- ▶ Call up settings menu. (see 5.2 Navigation)
- ▶ Swipe left or right until corresponding function is displayed.

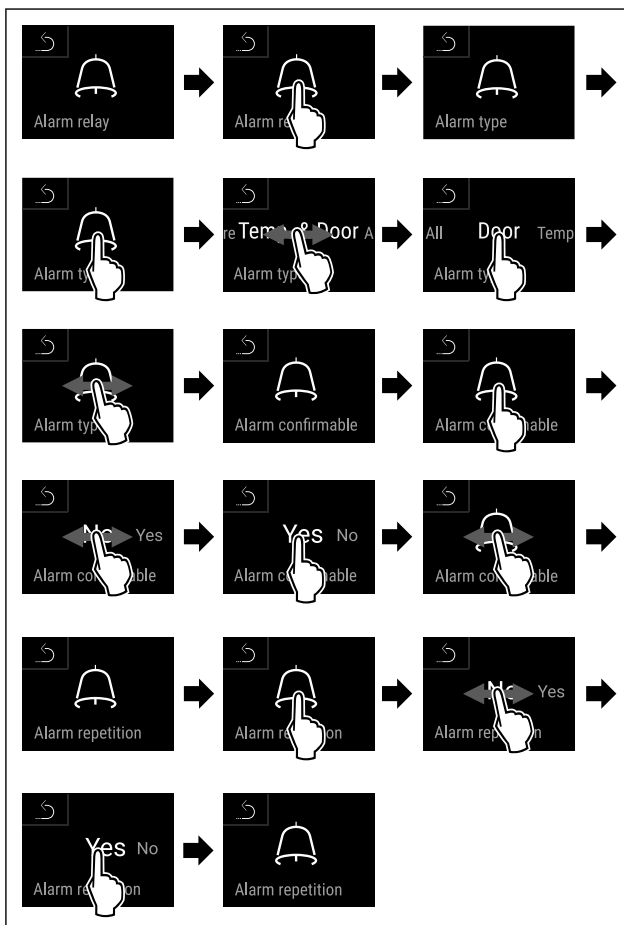
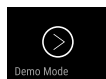

Fig. 138

- ▶ Carry out action steps according to the illustration.
- ▷ The alarm relay has been set.



5.3.29 Demo mode

Demo mode is a special feature for dealers who want to demonstrate appliance features. If you activate demo mode, all refrigeration functions are deactivated.

If you switch on your appliance and a "D" appears on the status display, demo mode is already activated.

If you activate and then deactivate demo mode, the appliance will be reset to factory defaults. (see 5.3.30 Factory reset)

Activating demo mode

- ▶ Open the customer menu. (see 5.2 Navigation)
- ▶ Swipe left or right until corresponding function is displayed.

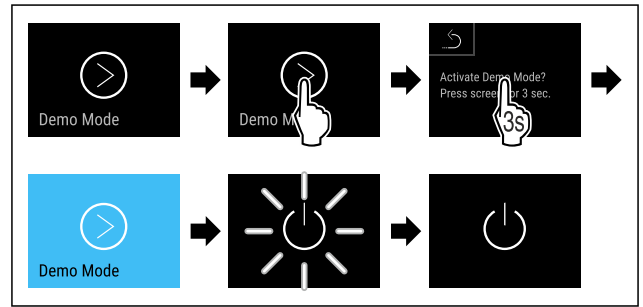

Fig. 139

- ▶ Carry out action steps according to the illustration.
- ▷ Demo mode is activated.
- ▷ Appliance is switched off.
- ▶ Restart the appliance. (see 3.16 Switching on the appliance (first use))

Deactivating demo mode

- ▶ Open the customer menu. (see 5.2 Navigation)
- ▶ Swipe left or right until corresponding function is displayed.

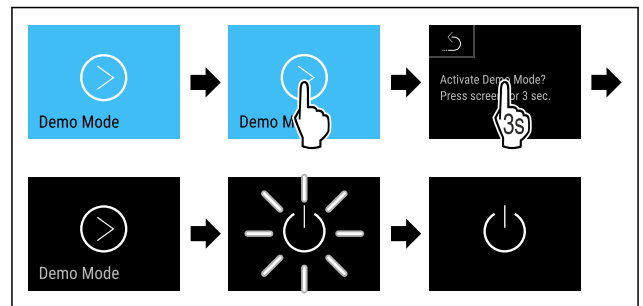

Fig. 140

- ▶ Carry out action steps according to the illustration.
- ▷ Demo mode is deactivated.
- ▷ Appliance is switched off.
- ▶ Restart the appliance. (see 3.16 Switching on the appliance (first use))

5.3.30 Factory reset



This function resets the appliance to the factory settings. All settings made up to this point are reset to their original values.

Performing factory reset

- ▶ Open the customer menu.
- ▶ Swipe left or right until corresponding function is displayed.

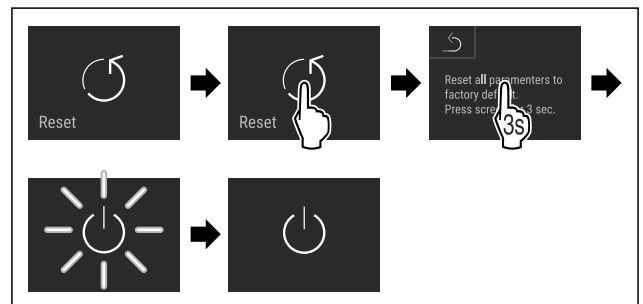

Fig. 141







- ▶ Carry out action steps according to the illustration.



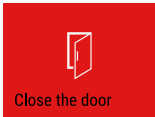

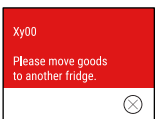
- ▷ Factory reset has been carried out.
- ▷ Appliance is switched off.
- ▶ Restart the appliance. (see 3.16 Switching on the appliance (first use))

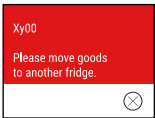
5.4 Messages

5.4.1 Warnings

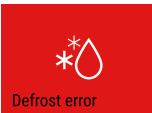
Warnings are issued by means of an audio signal and visually via a symbol on the display. The signal gets louder until the warning is acknowledged.

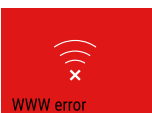
Message (red)	Cause	Remedy
 <p>Door open</p>	<p>The message appears if the door is open for too long.</p>	<p>Close the door.</p> <p>Press briefly</p> <p>Alarm is stopped.</p> <p>Note</p> <p>You can set how long it takes for this message to appear (see 5.3.24 Door alarm).</p>
 <p>Temperature alarm</p>	<p>This message appears if the temperature does not match the set temperature. Reasons for differences in temperature can be:</p> <p>Warm produce for cooling has been placed inside.</p> <p>Too much warm room air flowed in when rearranging and removing food.</p> <p>The power was cut off for a prolonged period.</p>	<p>Press briefly</p> <p>Information about errors and appliance status are displayed.</p> <p>Press briefly</p> <p>Warmest/coldest temperature, date and time are displayed.</p> <p>Press briefly</p> <p>The status screen is displayed.</p> <p>The current temperature and the alarm symbol flash red until the set temperature is reached.</p> <p>Check the quality of the refrigerated goods.</p>
 <p>Error</p>	<p>The appliance is malfunctioning, there is an appliance error or a component of the appliance has a fault.</p>	<p>Store refrigerated items elsewhere.</p> <p>Press briefly</p> <p>The error code (e.g. BT021) is displayed.</p> <p>Press briefly</p> <p>A further error code is displayed if there is one</p> <p>or</p> <p>Status screen is displayed with flashing error symbol.</p> <p>Swiping or tapping the display will show the error code(s) again.</p> <p>Make a note of error code(s) and contact Customer Service. (see 8.3 Customer Service)</p>  
	<p>The message indicates that freeze protection mode is active (e.g. due to frequent door openings or loading with goods).</p>	<p>Press briefly</p> <p>FRZ.PROT is displayed.</p> <p>Press briefly</p> <p>Status screen is displayed with flashing error symbol.</p>   <p>Swiping or tapping the display will show the message again.</p> <p>After a few hours, the appliance goes back to normal operating mode automatically and the message disappears. Alternatively, prolonged pressing will exit the mode and close the message. If it appears again, contact Customer Service. (see 8.3 Customer Service)</p>

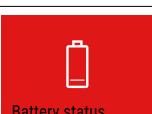
Message (red)	Cause	Remedy
 <p>Power failure</p> <p>Power failure</p>	<p>The message appears following an interruption to the electricity supply.</p> <p>The operating panel continues running in battery mode. All functions remain active except for refrigeration and lighting.</p>	<p>Press briefly</p> <p>Battery's state of charge, information about errors and appliance status are displayed</p> <p>Press briefly</p> <p>Highest temperature, time period and number of electricity supply interruptions are displayed.</p> <p>Press briefly</p> <p>The status screen is displayed.</p> <p>The current temperature and the alarm symbol flash red until the set temperature is reached.</p> <p>Check the quality of the refrigerated goods.</p>
 <p>Defrost error</p> <p>Defrost error</p>	<p>The automatic defrosting is not working properly. The previous 5 defrost cycles were not successful.</p>	<p>Press briefly.</p> <p>Alarm is stopped.</p> <p>Contact Customer Service (see 8.3 Customer Service).</p>
 <p>WiFi error</p> <p>WiFi error</p>	<p>WiFi connection is interrupted.</p>	<p>Check connection.</p> <p>Press briefly.</p> <p>Alarm is stopped.</p>
 <p>WWW error</p> <p>WWW error, WiFi</p>	<p>This message appears if there is no internet connection via WiFi.</p>	<p>Check connection.</p> <p>Press briefly.</p> <p>Alarm is stopped.</p>
 <p>LAN error</p> <p>LAN error</p>	<p>LAN connection is interrupted.</p>	<p>Check connection and network cable.</p> <p>Press briefly.</p> <p>Alarm is stopped.</p>
 <p>WWW error</p> <p>WWW error, LAN</p>	<p>This message appears if there is no internet connection via LAN.</p>	<p>Check connection.</p> <p>Press briefly.</p> <p>Alarm is stopped.</p>
 <p>Battery status</p> <p>Battery error</p>	<p>Low appliance battery level (max. 20% remaining).</p>	<p>Reconnect the appliance to a power supply and check whether the battery charge level has increased after 12 hours. Otherwise contact Customer Service (see 8.3 Customer Service) or replace the battery. (see 7.4 Replacing appliance battery)</p> <p>Press briefly.</p> <p>Alarm is stopped.</p>

5.4.2 Reminders

Reminders appear when you are prompted to take action. They are issued by means of an audio signal and visually via a symbol on the display. Acknowledge the message by pressing the confirmation button.

Message (yellow)	Cause	Remedy
 <p>Maintenance</p> <p>Maintenance reminder</p>	<p>The message appears when the timer for the set maintenance interval has expired.</p>	<p>Press briefly.</p> <p>Reminder is closed.</p> <p>Note</p> <p>The maintenance interval can be set (see 5.3.8 Maintenance interval reminder).</p>

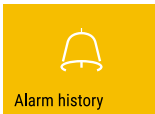
Message (yellow)	Cause	Remedy
 <p>Logging reminder</p>	This message appears when the temperature logging memory (999 hours) is full.	Press briefly. Reminder is closed. The oldest data is overwritten. Note The temperature logging can be reset (see 5.3.4 Temperature recording).
 <p>Alarm log</p>	The message appears if there are more than 10 unconfirmed alarm messages.	Press briefly. Check messages. Reminder is closed.

6 Equipment

6.1 Safety lock

The lock in the appliance door is equipped with a safety mechanism.

6.1.1 Locking appliance

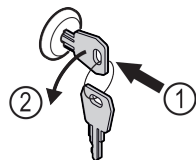

Fig. 142

- ▶ Insert key.
- ▶ Turn key anticlockwise by 90°.
- ▷ The appliance is locked.

6.1.2 Unlocking appliance

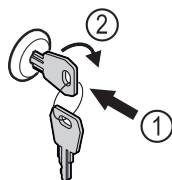

Fig. 143

- ▶ Insert key Fig. 143 (1).
- ▶ Turn key clockwise by 90° Fig. 143 (2).
- ▷ The appliance is unlocked.

6.2 Sensors

The appliance can be equipped with the following sensors for temperature monitoring:

- Safety thermostat sensor
- C sensor
- P sensor

6.2.1 Safety thermostat sensor

The safety thermostat sensor monitors the temperature drop and thus protects against excessively low temperatures (Freeze Protect). If the temperature drops below the threshold value, the appliance regulates the temperature automatically. The error message FRZ. PROT (Freeze Protect) (see 5.4 Messages) appears.

Note

Do not cover the safety thermostat sensor.

6.2.2 C sensor (control sensor)

The C sensor is permanently installed and regulates the interior temperature of the appliance. You can calibrate the C sensor if necessary. (see 5.3.22 Sensor calibration)

6.2.3 P sensor (reference sensor)

The P sensor is permanently installed in the interior, in order to record and monitor the temperature in this location specifically. If the set temperature is exceeded in this location, the sensor triggers an alarm. You can calibrate the P sensor if necessary. (see 5.3.22 Sensor calibration)

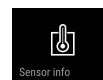

6.3 Sensor info

This function makes it possible to choose between C sensor or P sensor.

Make sure that the following requirement is met:

- P sensor is connected to the appliance. (see 6.4 Interfaces)

6.3.1 Selecting C sensor

- ▶ Open the customer menu.
- ▶ Swipe left or right until corresponding function is displayed.

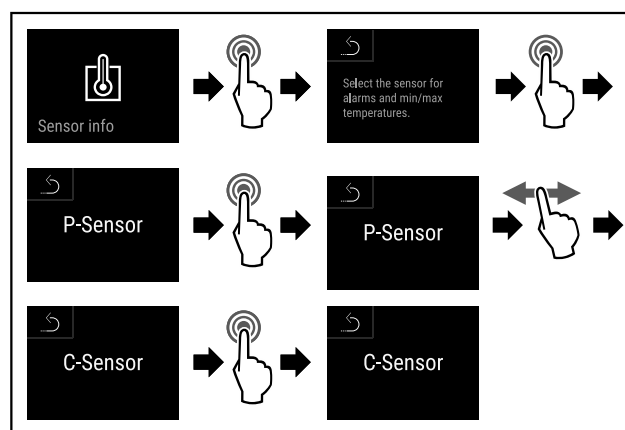

Fig. 144

- ▶ Complete steps (see Fig. 144).
- ▷ C sensor has been selected.

6.3.2 Selecting P sensor

- ▶ Open the customer menu.
- ▶ Swipe left or right until corresponding function is displayed.

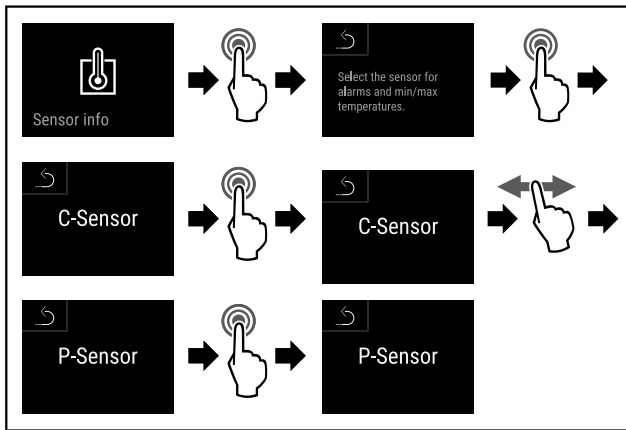

Fig. 145

- ▶ Complete steps (see Fig. 145).
- ▷ P sensor has been selected.

6.4 Interfaces

There are various connection options on the back of the appliance.

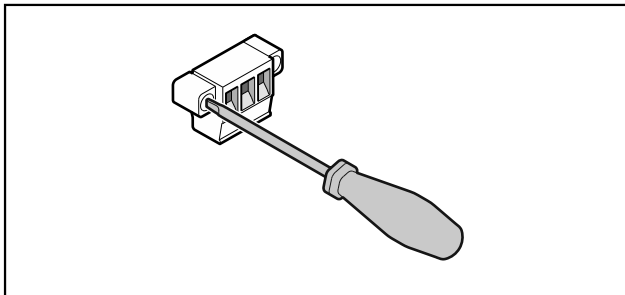

Fig. 146

Note

Screws secure the plugs. To enable disconnection of the plugs, loosen the screws on the left and right.

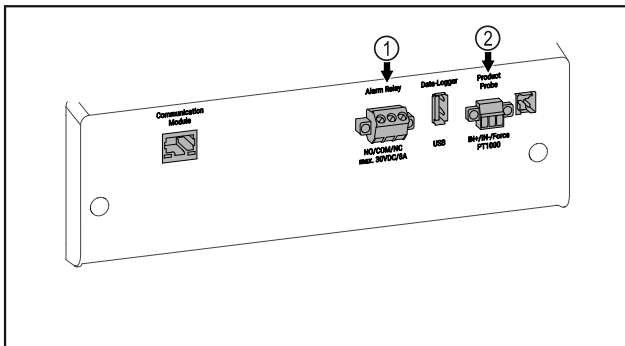

Fig. 147

- (1) Potential-free alarm output
- (2) Connection for P sensor output

6.4.1 Potential-free alarm output



WARNING

Risk of injury due to electric shock!

- ▶ The appliance may only be connected to an external alarm device by trained specialist personnel.

These three contacts can be used to connect a visual or an acoustic alarm device. The connection is designed for a maximum of **30 V (DC) - 8 A** from a safety low voltage source SELV (**minimum current 150 mA**).

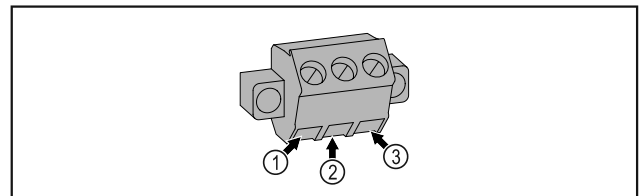

Fig. 148

- (1) NO (normally open)
Connection for indicator lamp, which is active in normal operation or when the appliance is switched off.
- (2) COM (common)
External voltage source
- (3) NC (normally closed)
Connection for alarm lamp or audible alarms, which is active when an alarm is triggered or lack of power supply.

6.4.2 Connection for P sensor

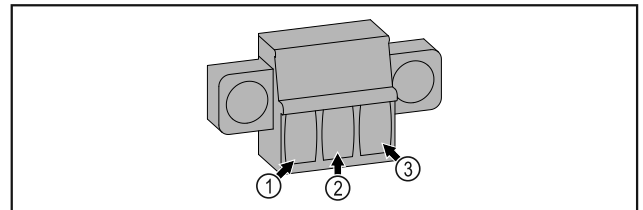

Fig. 149

- (1) IN+ (measuring line +)
- (2) IN- (common return line -)
- (3) FORCE (supply +)

7 Maintenance

7.1 Maintenance schedule

Maintenance work is to be performed at regular intervals to ensure proper appliance function.



CAUTION

Danger of injury and damage due to unprofessional maintenance work!

Personal injury and material damage.

- ▶ Maintenance work may only be performed by trained specialist personnel.



WARNING

Short-circuit hazard due to live parts!

Electric shock or damage to the electronics.

- ▶ **Switch off the appliance.**
- ▶ Pull out mains plug or switch off fuse.

Note

A maintenance reminder function can be activated. (see 5.3.8 Maintenance interval reminder)

Note

We recommend creating a maintenance log in which all work (repairs, checks) performed is documented.

Note

Liebherr recommends yearly maintenance. For an individual offer, please contact Customer Service (see 8.3 Customer Service).

Component	Activity	Maintenance interval
Sheet metal parts	Check for damage and corrosion. Replace damaged parts: (see 8.3 Customer Service)	Yearly
Door, hinges	Check alignment (see 3.14 Aligning the door) , ease of movement, and tight fit.	Yearly
Lock, door handle *	Check for ease of movement and tight fit.	Yearly
Door seal	Check for damage, wear, and tight fit. A replacement door gasket is available via Customer Service (see 8.3 Customer Service) .	Yearly
Sensor	Calibrate sensor. (see 5.3.22 Sensor calibration)	Yearly
Sensor feedthrough	Check that the sealing compound is intact.	Yearly
Battery	Replace appliance battery. A replacement battery is available from customer service. (see 7.4 Replacing appliance battery)	5 to 10 years
Surfaces	Cleaning (see 7.3 Cleaning the appliance)	Recommendation: monthly or as required/specified at installation location
Surfaces	Disinfection	Recommendation: monthly or as required/specified at installation location
Installation location, appliance	Decontamination The appliance is suitable for room decontamination with hydrogen peroxide H ₂ O ₂ . In this context, the values of the following application specifications must not be exceeded: Concentration: maximum 250 ppm. Humidity: maximum 85%. Maximum permissible room temperature as per climate class. (see 1.4 Range of appliance use)	Recommendation: as required/specified at installation location, maximum 2x per year
Fan air slots	Cleaning (see 7.3.3 Cleaning fan cover)	Yearly
Alarm relay Sensor	Check plug connections for tight fit.	Yearly
Power cable	Check for damage.	Yearly or if there is a change of location
Tilt angle	Check for proper function and tight fit.	Yearly or if there is a change of location
Adjusting feet/castors	Check for proper function, damage, and tight fit. Replace damaged parts. (see 8.3 Customer Service)	Yearly

7.2 Defrosting the appliance



WARNING

Appliance incorrectly defrosted!
Injuries and damage.

- ▶ Do not use mechanical devices or other means to accelerate the defrosting process, other than those recommended by the manufacturer.
- ▶ Do not use any electrical heating or steam cleaning equipment, naked flames or defrosting sprays.
- ▶ Do not remove ice with sharp objects.

Defrosting is performed automatically. The water from the defrosting process runs out via the drain opening and is evaporated.

To maintain the functionality of the appliance, we recommend defrosting it when there is a high buildup of ice. Icing in the interior is determined by the location (e.g. high humidity), settings on the appliance and incorrect user behavior.

Manual defrosting:

- ▶ Switch off appliance. (see 5.3.2 Switching appliance on and off)
- ▶ Disconnect power plug.
- ▶ Store refrigerated items elsewhere.
- ▶ Leave the appliance door open during defrosting process.
- ▶ Soak up remaining defrost water with a cloth, clean the drain opening and the appliance.

Maintenance

7.3 Cleaning the appliance

7.3.1 Preparing



WARNING

Short-circuit hazard due to live parts!
Electric shock or damage to the electronics.

- ▶ **Switch off the appliance.**
- ▶ Pull out mains plug or switch off fuse.



WARNING

Danger of fire

- ▶ Do not damage the refrigerant circuit.

- ▶ Empty the appliance.
- ▶ Pull out the power plug.

7.3.2 Cleaning the housing

NOTICE

Improper cleaning!
Damage to the appliance.

- ▶ Only use soft cleaning cloths and ph-neutral all-purpose cleaners.
- ▶ Do not use steel wool or sponges that scour or scratch.
- ▶ Do not use caustic or abrasive cleaning materials or those containing sand, chloride, or acids.



WARNING

Risk of injury or damage due to hot steam.
Hot steam can cause scalding/burns and damage to surfaces.

- ▶ Do not use steam cleaners.

NOTICE

Risk of damage due to short circuit.

- ▶ When cleaning the appliance, make sure no water gets into the electrical components.

- ▶ Wipe the housing down with soft, clean cloth. If very dirty, use lukewarm water with a neutral cleaner. Glass surfaces can also be cleaned with glass cleaner.
- ▶ Clean the condenser coil every year. If the condenser coil is not cleaned, this significantly reduces the efficiency of the appliance.

7.3.3 Cleaning fan cover

NOTICE

Risk of damage due to short circuit.

- ▶ When cleaning the appliance, make sure no water gets into the electrical components.

NOTICE

Improper cleaning!
Damage to the appliance.

- ▶ Only use soft cleaning cloths and ph-neutral all-purpose cleaners.
- ▶ Do not use steel wool or sponges that scour or scratch.
- ▶ Do not use caustic or abrasive cleaning materials or those containing sand, chloride, or acids.

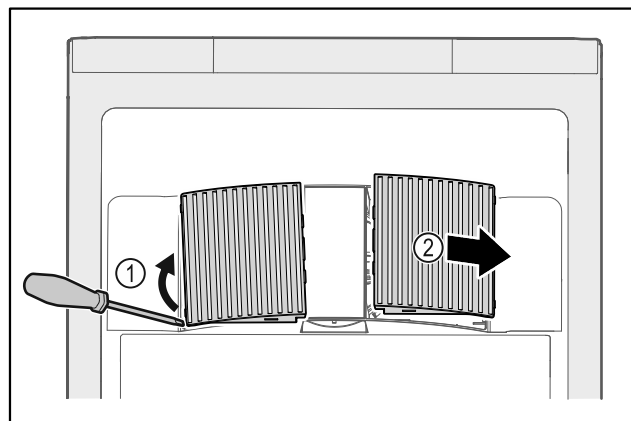

Fig. 150

- ▶ Carefully lever out fan covers from the side Fig. 150 (1) and remove towards the front Fig. 150 (2).
- ▶ Rinse the air slots of the fan covers under running water. If very dirty, use lukewarm water with a neutral cleaner.
- ▶ Leave fan covers to air-dry completely.
- ▶ Reattach fan covers to the appliance.

7.3.4 Cleaning the interior



WARNING

Short-circuit hazard due to live parts!
Electric shock or damage to the electronics.

- ▶ **Switch off the appliance.**
- ▶ Pull out mains plug or switch off fuse.



WARNING

Risk of injury or damage due to hot steam.
Hot steam can cause scalding/burns and damage to surfaces.

- ▶ Do not use steam cleaners.

NOTICE

Improper cleaning!
Damage to the appliance.

- ▶ Only use soft cleaning cloths and ph-neutral all-purpose cleaners.
- ▶ Do not use steel wool or sponges that scour or scratch.
- ▶ Do not use caustic or abrasive cleaning materials or those containing sand, chloride, or acids.

Note

- ▶ Defrost water drain (see 1.2 Overview of appliance and equipment) : Remove deposits using a thin object (e.g. a cotton bud).

Note

Do not damage or remove the type plate on the inside of the appliance. The type plate is important for Customer Service. (see 8.3 Customer Service)

- ▶ Open the door.
- ▶ Empty the appliance.
- ▶ Clean the interior and equipment parts with lukewarm water and a little dish detergent. Do not use any gritty or acidic cleaning agent or any chemical solvent.

7.3.5 After cleaning

- ▶ Wipe the appliance and equipment parts dry.
- ▶ Connect and switch on appliance.
When the temperature is sufficiently cold:
- ▶ Place in items for refrigeration.

- ▶ Clean regularly.
- ▶ Clean and dust appliances with a heat exchanger (metal grill on rear of appliance) once per year.

7.4 Replacing appliance battery

In the event of a power failure, the appliance battery is used to record temperature history, alarm and service messages and to show the alarm messages on the display for approximately 12 hours. During initial commissioning, the battery may take up to 24 hours to charge and be in proper working order.

A replacement battery is available from customer service (see 8.3 Customer Service).

7.4.1 Replacing the battery



WARNING

Short-circuit hazard due to live parts!
Electric shock or damage to the electronics.

- ▶ **Switch off the appliance.**
- ▶ Pull out mains plug or switch off fuse.

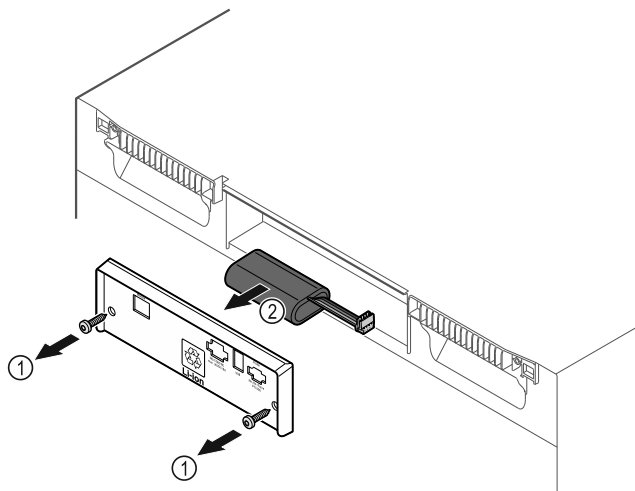

Fig. 151

- ▶ Unscrew screws and remove cover from the back of the appliance Fig. 151 (1).
- ▶ Disconnect and remove battery Fig. 151 (2).
- ▶ Install replacement battery.
- ▶ Close cover and screw in screws.
- ▶ Reconnect mains power cable.

Note

- ▶ The battery must be sent for separate waste treatment and disposed of properly and professionally in accordance with the locally applicable regulations and laws. **Do not damage or short circuit the battery!**

Maximum load per shelf ^{A)}		
Appliance width	600 mm	750 mm
Glass shelf	40 kg	40 kg
Wooden grid shelf	45 kg	60 kg

A) Heavier loads may result in a slight bending of the shelves.

Maximum total load and net weight		
Model (see 3.2 Appliance dimensions)	Maximum total load	Net weight
SRF.. 3501*	180 kg*	60 kg*
SRF.. 3511*	180 kg*	75 kg*
SRF.. 4001*	225 kg*	65 kg*
SRF.. 4011*	225 kg*	82 kg*
SRF.. 5501*	300 kg*	80 kg*
SRFvh 5511*	300 kg*	98 kg*

Maximum net capacity

See net capacity on the type plate. (see 1.2 Overview of appliance and equipment)

Lighting

Energy efficiency class ^{A)}	Light sources
This product contains one or more energy efficiency class F light sources	LED

A) The appliance may contain light sources with different energy efficiency classes. The lowest energy efficiency class is indicated.

WiFi frequency information

Frequency band	2.4 GHz
Maximum radiated power	<100 mW
Purpose of the wireless equipment	Integration in the local WiFi network for data communication

Setup conditions

Degrees of pollution (surrounding the appliance)	PD2
Ambient temperature	+10 °C to +35 °C
Maximum relative ambient moisture	75%, not condensing
Maximum operating elevation (meters above sea level)	2000 m 1500 m (glass door)

Electrical values

Nominal voltage	220-240 V ~
Frequency	50/60 Hz
Connected load	2,0 A
Maximum power supply fluctuation	+/-10%
Overvoltage categories	II

8 Customer support

8.1 Technical data

Temperature range	
Refrigeration	+3 °C to +16 °C

Maximum load per shelf ^{A)}		
Appliance width	600 mm	750 mm
Grid shelves	45 kg	60 kg

Data according to DIN 13277				
Model SRFvh	Energy consumption (kWh/24h)	Temperature increase – power failure (min.)	Temperature homogeneity (°K)	Temperature consistency (°K)
4001	0.460	95	1.7	1.0
4011	0.741	65	2.7	1.7
5501	0.498	115	1.1	0.9
5511	0.794	65	1.6	1.0

Appliance battery	
Type	1S2P/NCR 18650BF

Appliance battery	
Nominal voltage	3.6 V DC
Capacity	6.7 Ah

8.2 Technical malfunction

Your appliance is designed and built to ensure it works reliably and has a long service life. If a malfunction nonetheless occurs during operation, please check whether the malfunction is due to an operating error. If this is the case, you will be charged for the cost incurred even if this falls within the warranty period.

You can rectify the following malfunctions yourself.

8.2.1 Appliance function

Defect	Cause	Remedy
The appliance is not working.	→ The appliance is not switched on.	▶ Switch on the appliance.
	→ The power plug is not properly inserted in the socket.	▶ Check the power plug.
	→ There is a problem with the wall socket breaker.	▶ Check the breaker.
	→ Power failure	▶ Keep the appliance closed. ▶ If necessary move the refrigerated/frozen items to another fridge or freezer if the power is off for a prolonged period.
	→ The appliance power plug is not correctly inserted in the appliance.	▶ Check the appliance power plug.
The temperature is not cold enough.	→ The appliance door is not closed properly.	▶ Close the appliance door.
	→ Ventilation is not sufficient.	▶ Unclog the ventilation grill and clean it.
	→ The ambient temperature is too high.	▶ Observe the suitable ambient conditions: (see 1.4 Range of appliance use)
	→ The appliance was opened too many times or for too long.	▶ Wait to see if the required temperature is achieved once again on its own. If not, contact Customer Service (see 8.3 Customer Service) .
	→ The temperature is set incorrectly.	▶ Set a colder temperature and check after 24 hours.
	→ The appliance is too close to a heat source (stove, heater etc).	▶ Move either the appliance or the heat source.

8.3 Customer Service

First check whether you can remedy the fault yourself . If this is not the case, please contact Customer Service.

You can find the address in the enclosed brochure “Liebherr-Service” or at home.liebherr.com/service.

8.3.1 Contacting Customer Service

Make sure you have the following appliance information ready:

- Appliance name (model and index)
- Service no. (service)
- Serial no. (S no.)
- ▶ Access the appliance information via the display (see 5.3.17 Info) .
- or-
- ▶ Refer to the type plate for appliance information. (see 8.4 Type plate)

- ▶ Note appliance information.
- ▶ Inform Customer Service: Report faults and the appliance information.
- ▷ This will help us to provide fast and focused service.
- ▶ Follow any further instructions provided by Customer Service.

8.4 Type plate

The type plate is inside the appliance. See appliance overview.

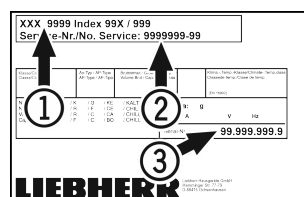

Fig. 152

- (1) Appliance designation (3) Serial No.
 (2) Service No.

9 Shutting down

- ▶ Empty the appliance.
- ▶ Switch off appliance.
- ▶ Pull out the power plug.
- ▶ Remove appliance connector if required: remove and at the same time move from left to right.
- ▶ Clean the appliance. (see 7.3 Cleaning the appliance)
- ▶ Leave the door open so that no bad odors form.

Note

Damage to the appliance and malfunctions!

- ▶ After shutting down, only store the appliance at the permitted room temperature of between -10 °C and +50 °C.



WARNING

Leaking refrigerant and oil!

Fire. The refrigerant contained within the appliance is environmentally friendly, but flammable. The oil contained within the appliance is flammable. Escaping refrigerant and oil can ignite if they are of high enough concentration and are exposed to an external heat source.

- ▶ Do not damage the pipelines of the coolant circuit and the compressor.

- ▶ Transport the appliance away without damaging it.
- ▶ Dispose of batteries, lamps, and the appliance according to the above specifications.

11 Additional information

Further information on warranty conditions can be found in the enclosed service brochure or on the Internet at <https://home.liebherr.com>.

10 Disposal

10.1 Preparing appliance for disposal



Liebherr uses batteries in some of its appliances. In the EU, for environmental reasons, legislation obliges the end user to remove these batteries before disposing of the old appliances. If your appliance contains batteries, a corresponding notice is attached to the appliance.

Lamps If you can remove the lamps yourself without destroying them, also remove these before disposal.

- ▶ Take the appliance out of operation.
- ▶ Appliance with batteries: Remove the batteries. For description, see **Maintenance** chapter.
- ▶ If possible: Remove lamps without destroying them.

10.2 Disposing of the appliance in an environmentally friendly manner



The appliance still contains valuable materials and must be collected separately from unsorted municipal waste so it can be recycled.



Dispose of batteries separately from the old appliance. You can do this by returning the batteries free of charge to retailers or taking them to recycling centers and collection centers for recyclable materials.

Lamps Dispose of removed lamps via the respective collection systems.

Notify in event of appliance malfunction: _____

Model ID/
Inventory number: _____

Quick Start Guide for everyday use

Information about using this Quick Start Guide:

- This Quick Start Guide is not a substitute for the full operating instructions nor is it a substitute for appliance training.
- This Quick Start Guide provides support for everyday use and handling the appliance.
- Read the full operating instructions and the safety instructions contained therein.

This quick start guide is for: SRFvh 40../55..



Using the QR code, you can read the full operating instructions.



Intended use

This laboratory refrigerator is suitable for professional storage of products at temperatures between 3 °C and 16 °C.

Foreseeable incorrect use

Do not use the appliance for the following applications:

- Storage and cooling of:
 - Chemically unstable, flammable or corrosive substances
 - Blood, plasma or other body fluids for the purpose of infusion, application or introduction in the human body
- Use in areas with risk of explosion
- Outdoor use or in areas where it is exposed to splash water or damp conditions

When stocking, observe the following points:

- Position grid shelves according to the height required.
- Observe maximum load.
- When the storage temperature has been reached, load the appliance (compliance with cold chain).
- Keep the ventilation slots of the recirculation fan free in the interior.
- Items for refrigeration must not come into contact with the evaporator on the rear wall.
- Keep liquids in closed containers.
- Leave space when storing items for refrigeration to ensure adequate air circulation.

Status display

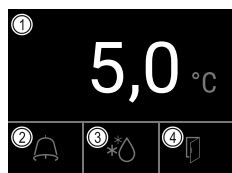

Fig. 153

- (1) Actual temperature (3) Defrosting status
(2) Alarm status (4) Door opening status

Navigation with the touch display

Navigation	Description
	Swipe right or left Navigates within the menu.
	Press briefly Activates/deactivates function. Confirms selection. Opens submenu.
	Long press (3 seconds) Activates/deactivates function.
	Brief press of Back symbol Jumps back one level.

Displaying temperature recording

The temperature recording displays the length of the recording and the minimum and maximum temperatures measured during this period of time.

- ▶ Swipe left or right until corresponding function is displayed.

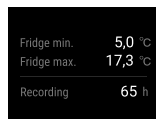

Fig. 154

Resetting temperature recording

- ▶ Swipe left or right until corresponding function is displayed.

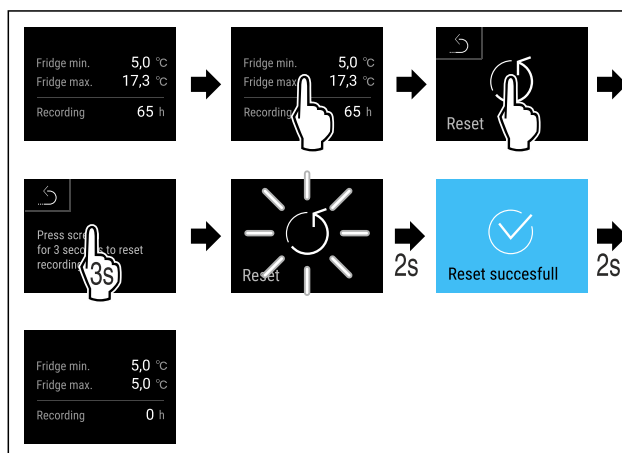

Fig. 155

- ▶ Carry out steps according to the illustration.

Quick Start Guide for everyday use

Unlocking appliance

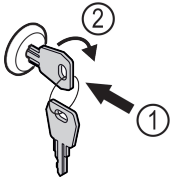

Fig. 156

- ▶ Insert the key. Fig. 156 (1)
- ▶ Turn the key clockwise by 90°. Fig. 156 (2)
- ▷ The appliance is unlocked.

Displaying alarm log

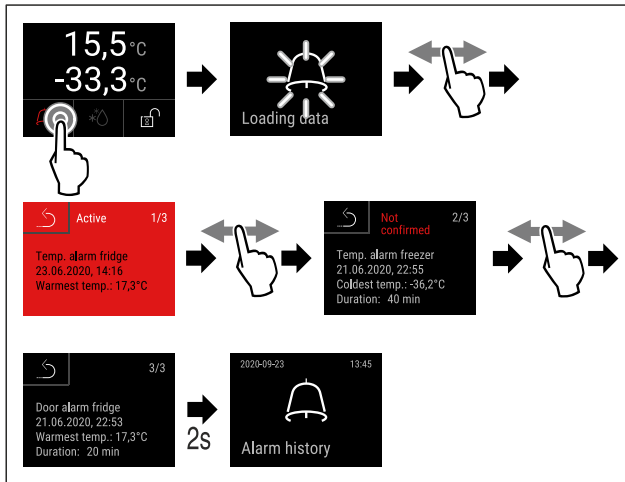

Fig. 157 Example shows an active alarm, an unconfirmed alarm, and a confirmed alarm.

- ▶ Carry out steps according to the illustration.
- ▷ Alarm log shows active, confirmed or unconfirmed alarms (maximum 10 alarms).
- ▷ To delete the alarm log: See operating instructions.

Cleaning appliance

- ▶ Empty the appliance.
- ▶ Pull out the power plug.
- ▶ Observe the information in the operating instructions.
- ▶ Dry the appliance and equipment thoroughly after cleaning.
- ▶ Connect the appliance.
- ▶ Switch on the appliance.
- ▶ Load the appliance once the storage temperature is reached.



What should I do if there is a fault?

A message appears in the display if there is a fault. Messages have different meanings:

Symbol color in the display	Meaning	Remedy
YELLOW	Reminder Reminder of general procedures. You can carry out these procedures to eliminate the message.	Consult the operating instructions and perform the troubleshooting steps.

Symbol color in the display	Meaning	Remedy
RED	Warning Appears when there are malfunctions. You can eliminate simple malfunctions yourself.	Consult the operating instructions and perform the troubleshooting steps.
If you cannot remedy the fault yourself, contact a competent member of staff or your nearest customer service outlet.		

Cut out the page





home.liebherr.com/fridge-manuals

EN ORIGINAL OPERATOR'S MANUAL

Issue date: 20230901

Part number index: 7080726-00

Liebherr Hausgeräte Lienz GmbH
Dr.-Hans-Liebherr-Strasse 1
A-9900 Lienz
Österreich

