



User Guide

Quality, Design and Innovation



home.liebherr.com/fridge-manuals









LIEBHERR

Contents

1	Appliance at a glance.....	3
1.1	Scope of supply.....	3
1.2	Overview of appliance and equipment.....	3
1.3	Special features.....	3
1.4	Range of use of appliance.....	3
1.5	Appliance noise emissions.....	4
1.6	Compliance.....	4
1.7	SVHC substances according to REACH regulation.....	4
2	General safety instructions.....	5
3	Functionality of the Touch display.....	6
3.1	Navigation and symbol explanation.....	6
3.2	Menus.....	7
3.3	Sleep mode.....	7
4	Putting into operation.....	7
4.1	Installation conditions.....	7
4.2	Appliance dimensions.....	8
4.3	Transporting appliance.....	8
4.4	Unpacking appliance.....	8
4.5	Removing transport lock.....	8
4.6	Installing door handle.....	9
4.7	Mounting anti-tipping device.....	9
4.8	Installing appliance.....	10
4.9	Setting up the appliance so it is level.....	10
4.10	Installing multiple appliances.....	10
4.11	After installation.....	10
4.12	Disposing of packaging.....	10
4.13	Reversing the door opening direction.....	10
4.14	Aligning the door.....	18
4.15	Connecting appliance.....	18
4.16	Switching on appliance (first use).....	19
5	Storage.....	19
5.1	Information regarding storage.....	19
6	Controls.....	19
6.1	Appliance functions.....	19
6.1.1	Notes on the appliance functions.....	19
6.1.2	Switching appliance on and off.....	19
6.1.3	Temperature.....	20
6.1.4	Temperature recording.....	20
6.1.5	Settings menu access protection.....	21
6.1.6	Access code.....	21
6.1.7	Maintenance interval reminder.....	22
6.1.8	Language.....	23
6.1.9	Temperature unit.....	23
6.1.10	Display brightness.....	23
6.1.11	Alarm Sound.....	23
6.1.12	Key Sound.....	24
6.1.13	WiFi connection.....	24
6.1.14	LAN connection.....	25
6.1.15	Device information.....	26
6.1.16	Operating hours.....	26
6.1.17	Software.....	26
6.1.18	Defrosting.....	27
6.1.19	Sensor calibration.....	27
6.1.20	Temperature alarm.....	28
6.1.21	Door alarm.....	29
6.1.22	Alarm simulation.....	29
6.1.23	Alarm relay.....	30
6.1.24	Demo mode.....	30
6.1.25	Resetting to factory settings.....	31
6.2	Messages.....	31
6.2.1	Warnings.....	31
6.2.2	Reminder.....	34
7	Features.....	34
7.1	Safety lock.....	34
7.2	Sensors.....	34
7.3	Interfaces.....	34
8	Maintenance.....	35

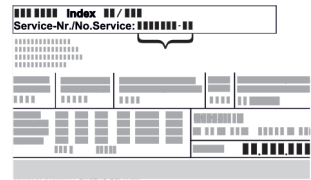
8.1	Maintenance schedule.....	35
8.2	Defrosting appliance.....	36
8.3	Cleaning the appliance.....	36
9	Customer help.....	37
9.1	Technical specifications.....	37
9.2	Technical fault.....	38
9.3	Customer Service.....	38
9.4	Type plate.....	39
10	Shutting down.....	39
11	Disposal.....	39
11.1	Preparing appliance for disposal.....	39
11.2	Disposing of the appliance in an environmentally friendly manner.....	39
12	Additional information.....	40
13	Quick Start Guide for everyday use.....	41

The manufacturer is continually working on the further development of all types and models. Please be aware that we reserve the right to make changes to the shape, equipment and technology.

Symbol	Explanation
	<p>Read instructions</p> <p>Please read the information in these instructions carefully to understand all of the benefits of your new appliance.</p>
	<p>Additional information on the Internet</p> <p>The digital manual with additional information and in other languages can be found via the QR code on the front of the manual or by entering the service number at home.liebherr.com/fridge-manuals.</p> <p>The service number can be found on the serial tag:</p>  <p style="text-align: right;"><i>Fig. Example illustration</i></p>
	<p>Check appliance</p> <p>Check all parts for transport damage. If you have any complaints, please contact your agent or customer service.</p>
	<p>Differences</p> <p>These instructions apply to a range of models, so differences are possible. Sections that apply to certain models only are marked with an asterisk (*).</p>
	<p>Instructions and results</p> <p>Instructions are marked with a ▶.</p> <p>Results are marked with a ▷.</p>
	<p>Videos</p> <p>Videos about the appliances are available on the YouTube channels of Liebherr-Hausgeräte.</p>

These operating instructions apply to:

- SRFfg 3501
- SRFfg 4001
- SRFfg 5501

1 Appliance at a glance

1.1 Scope of supply

Check all parts for transport damage. If you have any complaints, please contact your dealer or Customer Service. (see 9.3 Customer Service)

The delivery comprises the following parts:

- Free-standing appliance
- Equipment *
- Installation materials *
- Operating instructions
- Service brochure
- Quality certificate *
- Mains cable
- Handle incl. screws and Torx wrench
- Wall fastening kit

1.2 Overview of appliance and equipment

SRFfg 3501
SRFfg 4001
SRFfg 5501

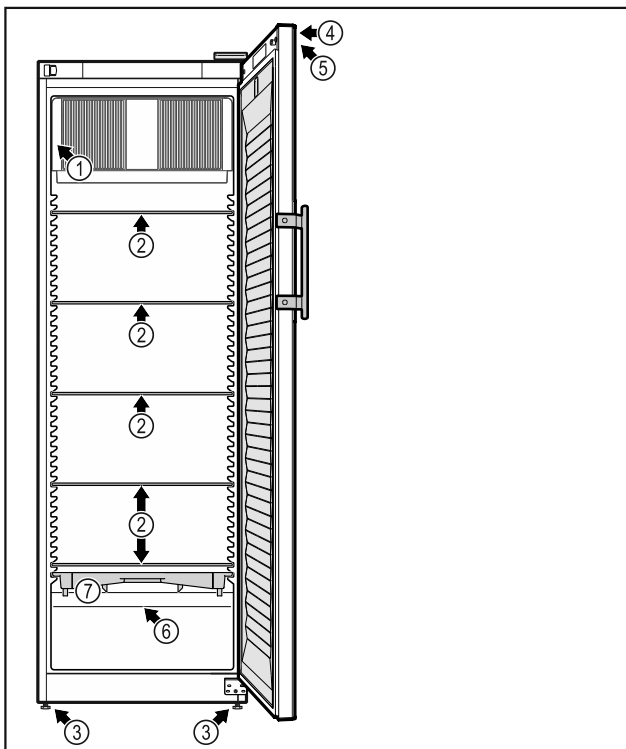

Fig. 1 Example illustration

Equipment

- | | |
|--------------------|--|
| (1) Type plate | (5) Control elements and temperature display |
| (2) Glass shelf | (6) Safety thermostat sensor |
| (3) Adjusting feet | (7) Defrost water collection tray |
| (4) Lock | |

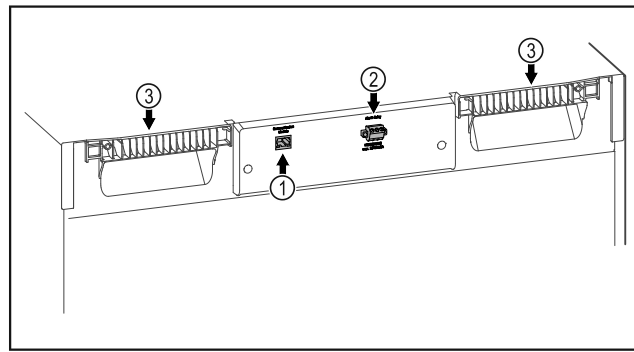

Fig. 2 Example illustration of the rear

Equipment

- | | |
|---------------------------------|------------------|
| (1) LAN/WiFi interface * | (3) Carrying aid |
| (2) Potential-free alarm output | |

1.3 Special features

Note

Accessories are available from Customer Service (see 9.3 Customer Service) and the Liebherr-Hausgeräte store at home.liebherr.com/shop/de/deu/zubehor.html.

SmartModule

The appliance can be fitted with a SmartModule.

This is a WiFi and LAN interface for the connection between the appliance and an external documentation and alarm system such as Liebherr SmartMonitoring.

Liebherr SmartMonitoring Dashboard is not available in all countries. Check availability via the QR code (see 6.1.13 WiFi connection) by entering your model.

Retrofitting drawers

Temperature qualification is required when retrofitting drawer systems in Liebherr refrigerators/freezers where these are used for temperature-sensitive materials such as chilled drugs and refrigerated products which are subject to specific standards requirements. Retrofitting drawers in Liebherr refrigerators/freezers can result in the goods stored becoming spoiled or damaged. The retrofitting must therefore be completed exclusively by authorised service providers from the manufacturer of the refrigerator/freezer.

1.4 Range of use of appliance

Intended use

This laboratory refrigerator, with an interior free of ignition sources, is suitable for professional storage of highly flammable products in closed containers, at temperatures between 3 °C and 16 °C.

Explosion-proof interior

The values relating to your appliance are printed on the sticker on the appliance door.

Appliance at a glance

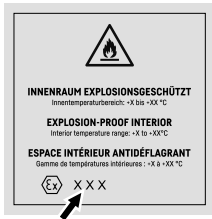

Fig. 3 Protection category: **II 3/-G Ex ec IIC T6 Gc/-**

The interior is permitted as a hazardous area as per 2014/34/EU (ATEX directive).

The following substances can be stored in suitable and tightly sealed containers:

- Research samples
- Reagents
- Laboratory inventory
- Chemicals such as ethanol, acetone, isopropanol, etc.

Observe the following specifications for storage:

- Observe the corresponding zone, explosion group and temperature class of the substances to be stored.
- Observe auto-ignition temperature. The auto-ignition temperature of the substances to be stored must be above temperature class T6 (> 85 °C).
- Refer to the relevant safety data sheet for the storage conditions of the products to be stored.
- Observe maximum storage quantities.
- Observe the prevailing directives if wanting to store different substances together.
- If unsure, consult with safety experts or suppliers as to whether the substance in question is suitable for storage.
- Observe local and specific directives and requirements to secure the safety of personnel and the facility.

The storage of temperature-sensitive substances requires the use of an independent, continuous monitoring alarm system. This alarm system must be designed in such a way that a responsible person can register any alarm status so that appropriate action can be taken.

Foreseeable incorrect use

Do not use the appliance for the following applications:

- Storage and refrigeration of:
 - Chemically unstable substances
 - Blood, plasma or other body fluids for the purpose of infusion, application or introduction in the human body.

- Use in potentially explosive atmospheres.
- Use outdoors or in areas exposed to dampness and splashing water.

Improper use of the appliances will result in goods stored being damaged or spoiled.

Climate classes

The applicable climate class for your appliance is printed on the type plate.

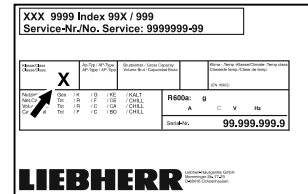

Fig. 4 Type plate

(X) This climate class indicates the ambient conditions in which the appliance can be safely operated.

Climate class (X)	max. room temperature	max. rel. humidity
7	35 °C	75%

Note

The minimum permitted room temperature at the setup location is 10 °C.

Slight condensation may form at the limit conditions on the glass door and on the side walls.

1.5 Appliance noise emissions

The A-weighted emission sound pressure level during operation of the appliance is under 70 dB(A) (sound power rel. 1 pW).

1.6 Compliance

The coolant circuit has been tested for leak-tightness.

This appliance complies with the applicable safety regulations and with EU directives 2014/35/EU, 2014/30/EU, 2014/34/EU and 2011/65/EU.

The full text of the EU Declaration of Conformity is available on the following website: www.liebherr.com

1.7 SVHC substances according to REACH regulation

You can check whether your appliance contains SVHC substances according to REACH regulation at the following link: home.liebherr.com/de/deu/de/liebherr-erleben/nachhaltigkeit/umwelt/scip/scip.html

2 General safety instructions

Please keep these operating instructions in a safe place so you can refer back to them at any time.

If you pass the appliance on, please hand these operating instructions to the next user.

Read these operating instructions carefully before use to ensure safe and correct use of the appliance. Follow the instructions, safety instructions and warning messages included at all times. They are important for ensuring you can operate and install the appliance safely and without any problems.

Danger for the user:

- This appliance may only be used by specialist and laboratory personnel who have been trained for this purpose and are familiar with all safety measures pertaining to laboratory work. Children and persons with reduced physical, sensory or mental capabilities or lack of experience and knowledge must not commission or operate this appliance.
- The socket must be easily accessible so that the appliance can be disconnected quickly from the electricity supply in an emergency. It must not be located in the area behind the appliance.
- When disconnecting the appliance from the supply, always take hold of the plug. Do not pull the cable.
- In the event of a fault pull out the mains plug or deactivate the fuse.
- **WARNING:** Do not damage the mains power cable. Do not operate the appliance with a defective mains power cable.
- **WARNING:** Multiple sockets/distributors and other electronic equipment (such as halogen transformers) must not be placed or operated at the rear of the appliance.
- **WARNING:** Keep ventilation openings, in the appliance enclosure or in the built-in structure, clear of obstruction.
- **WARNING:** Dust deposits on fan blades! Risk of sparking due to friction! Do not store dusty objects in the appliance. The ventilation slots of the recirculation fan must be cleaned each month using a vacuum cleaner.
- Only customer service or other specially trained staff may repair or perform other operations on the appliance.
- Only assemble, connect and dispose of the appliance according to the instructions.

Fire hazard

- The coolant used (information on the model plate) is ecofriendly but also flammable. Any leaking coolant may ignite.
 - **WARNING:** Do not damage refrigeration circuit.
 - Do not handle ignition sources inside the appliance.
 - **WARNING:** Do not use electrical appliances in the fridge compartment which do not comply with the design recommended by the manufacturer.
 - If the refrigerant leaks: remove any naked flames or ignition sources from the vicinity of the leakage point. Properly air the room. Inform customer services.
- Do not operate the appliance close to explosive gases.
- Do not store or use petrol or other flammable gases and liquids close to the appliance.
- Keep burning candles, lamps and other items with naked flames away from the appliance so that they do not set the appliance on fire.

Danger of tipping and falling:

- **WARNING:** In order to prevent danger due to an unstable appliance, it must be fixed in accordance with the instructions.
- Do not misuse the plinth, drawers, doors etc. as a step or for support.

Danger of frostbite, numbness and pain:

- Avoid prolonged skin contact with cold surfaces or refrigerated/frozen goods or take protective measures, e.g. wear gloves.

Danger of injury and damage:

- **WARNING:** Do not use mechanical equipment or other methods to speed up the defrosting process other than those recommended by the manufacturer.
- **WARNING:** Risk of injury due to electric shock! There are live electrical parts under the cover.
- **NOTICE:** Appliance must only be used using original manufacturer accessories or using accessories from other providers approved by the manufacturer. The user bears the risk of using accessories which are not approved.

Risk of crushing

- Do not hold the hinge when opening and closing the door. Fingers may get caught.

Functionality of the Touch display

Specialist personnel qualifications:

The appliance may only be installed, tested, maintained, and commissioned by specialist personnel who are familiar with the installation, commissioning, and operation of the appliance.

Specialist personnel are persons who, on account of their specialist training, knowledge and experience as well as their knowledge of the relevant standards, are able to assess and perform the work assigned to them and identify potential hazards. They must have training, instruction, and authorisation to work on the appliance.

Symbols on the appliance:



This symbol may be located on the compressor. It relates to the oil in the compressor and makes reference to the risk that: **Swallowing or inhaling can be fatal.** This advice is only relevant to recycling. There is no danger in normal operation.



WARNING: Danger of fire / flammable materials. This symbol is located on the compressor and indicates the danger of flammable materials. Do not remove the sticker.

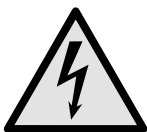

The symbol is located on the back of the appliance near the alarm relay and indicates the following danger: **Electric shock!** Even if an appliance is disconnected from the mains there may still be extraneous voltage. Do not remove sticker.



This or a similar sticker may be located on the rear of the appliance. This sticker indicates that there are vacuum insulation panels (VIP) or perlite panels in the door and/or housing. This advice is only relevant to recycling. Do not remove the sticker.

Please note the warning messages and other specific advice in the other chapters:

	DANGER	Indicates an immediately hazardous situation which will lead to death or serious injuries if it is not avoided.
	WARNING	Indicates a hazardous situation which will lead to death or serious injuries if it is not avoided.
	CAUTION	Indicates a hazardous situation which will lead to minor or moderate injuries if it is not avoided.
	NOTICE	Indicates a hazardous situation which may lead to damage to property if it is not avoided.
	Note	Indicates useful instructions and tips.

3 Functionality of the Touch display

You operate your appliance using the Touch display. You select appliance functions in the Touch display (hereafter referred to as display) by tapping them. If you do not perform any action on the display for 10 seconds, the display either jumps back to the higher-level menu or directly to the status display.

3.1 Navigation and symbol explanation

In the illustrations, different symbols are used to navigate the display. The following table describes these symbols.

Symbol	Description
	Press the Next navigation arrow: Navigates to the next option in the menu.
	Press the Back navigation arrow: Jumps back one option in the menu.
	Press and hold the Back navigation arrow for 3 seconds: Jumps back to the status display in the main menu or from the Settings menu.
	Press the navigation arrow several times in succession: Navigates in the menu to the desired function.
	Press the Confirm symbol: Activates/deactivates function. Opens submenu.
	Press the Confirm symbol together with the back icon: Jumps back one menu level.
	Arrow with clock: It takes more than 10 seconds for the following message to appear in the display.
	Arrow with a time indication: It takes the specified amount of time until the following message appears in the display.
	“Open Settings menu” symbol: Navigates to the Settings menu and opens the settings menu. If necessary: Navigate to the desired function in the Settings menu. (see 3.2.1 Opening the Settings menu)

Symbol	Description
	<p>“Open Advanced menu” symbol:</p> <p>Navigates to the Advanced menu and opens the advanced menu.</p> <p>If necessary: Navigate to the desired function in the Advanced menu.</p> <p>(see 3.2.2 Opening the Advanced menu)</p>
No action for 10 seconds	If you do not perform any action on the display for 10 seconds, the display either jumps back to the higher-level menu or directly to the status display.
Opening door and closing it again	If you open the door and immediately close it again, the display jumps directly back to the status display.

Note: Illustrations of the display are shown in the English version.

3.2 Menus

The appliance functions can be found in various menus.

Menu	Description
Main menu	When you switch the appliance on, you are automatically in the main menu. From here you can navigate to the most important appliance functions, to the Settings menu and to the Advanced menu.
 Settings menu	The Settings menu contains additional appliance functions for setting up your appliance. (see 3.2.1 Opening the Settings menu)
 Advanced menu	The advanced menu contains special appliance functions for setting up your appliance. Access to the Advanced menu is protected by the numerical code 151 . (see 3.2.2 Opening the Advanced menu)

3.2.1 Opening the Settings menu

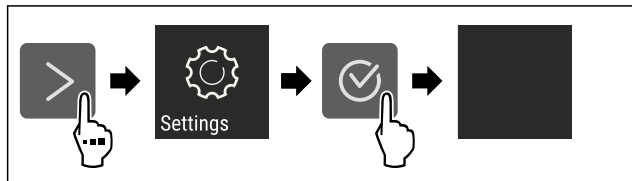

Fig. 5 Example illustration

- ▶ Carry out action steps according to the illustration.
- ▷ Settings menu is open.
- ▶ If necessary: Navigate to the desired function.

3.2.2 Opening the Advanced menu

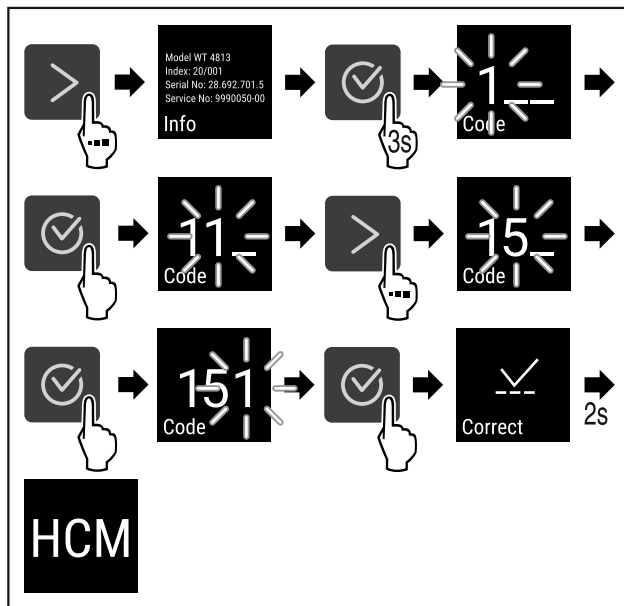

Fig. 6 Access with numerical code **151**

- ▶ Carry out action steps according to the illustration.
- ▷ The expanded menu is open.
- ▶ If necessary: Navigate to the desired function.

3.3 Sleep mode

If you do not touch the display for 1 minute, the display switches to sleep mode. In sleep mode, the display brightness is dimmed.

3.3.1 Ending sleep mode

- ▶ Press any navigation key.
- ▷ Sleep mode is ended.

4 Putting into operation

4.1 Installation conditions



WARNING

Fire hazard due to dampness!

If live parts or the mains lead become damp this may cause short circuits.

- ▶ The appliance is designed for use in enclosed areas. Do not operate the appliance outdoors or in areas where it is exposed to splash water or damp conditions.

4.1.1 Installation location



WARNING

Leaking coolant and oil!

Fire. The coolant contained in the appliance is eco-friendly, but also flammable. The oil contained in the appliance is flammable. Escaping coolant and oil can ignite if the concentration is high enough and in contact with an external heat source.

- ▶ Do not damage the pipelines of the coolant circuit and the compressor.

- Do not install appliance in direct sunlight, next to an oven, radiator or similar.

Putting into operation

- The best place for installation is a dry and well ventilated room.
- If the appliance is installed in a very humid environment, condensation can form on the outside of the appliance. Always ensure good airflow and ventilation in the installation location.
- The more refrigerant there is in the appliance, the larger the space it is installed in must be. If the space is too small, any leak may create a flammable mixture of gas and air. For every 8 g of refrigerant, the installation space must be at least 1 m³. Information regarding the refrigerant can be found on the type plate inside the appliance.
- The floor of the location must be horizontal and even.
- The installation location must be able to withstand the weight of the appliance plus weight when stocked to maximum level. (see 9.1 Technical specifications)
- Use in hazardous areas is not permitted.

4.1.2 Electrical connection



WARNING

Danger of fire due to incorrect positioning!

If the mains cable or plug touches the back of the appliance, the vibration can damage the mains cable or the plug resulting in a short circuit.

- ▶ Make sure the mains cable is not trapped under the appliance when you position the appliance.
- ▶ Stand the appliance so that it is not touched by connectors or main cables.
- ▶ Do not connect any appliances to sockets in the area of the back of the appliance.
- ▶ Do **not** place and operate multi-sockets/power distributors and other electronic devices (such as halogen transformers) at the back of the appliances.

4.2 Appliance dimensions

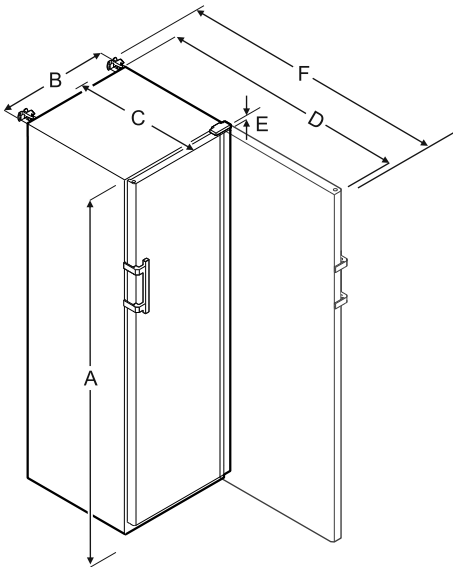

Fig. 7

	SRFfg 3501	SRFfg 4001
A	1684 mm	1884 mm
B	597 mm	597 mm
C	664 mm	664 mm
D	1203 mm	1203 mm
E	23 mm	23 mm

	SRFfg 3501	SRFfg 4001
F	1241 mm	1241 mm

	SRFfg 5501
A	1684 mm
B	747 mm
C	779 mm
D	1468 mm
E	23 mm
F	1506 mm

A = appliance height including feet/castors

B = appliance width without handle [handle depth = 45 mm]

C = appliance depth without handle [handle depth = 45 mm]

D = appliance depth with door open

E = hinge height

F = appliance depth with protruding handle and anti-tipping device

4.3 Transporting appliance



WARNING

Risk of injury and damage due to the appliance tipping over!

- ▶ Pay attention to uneven floors and ramps when transporting appliances.

Note when transporting the appliance:

- ▶ Transport the appliance upright.
- ▶ Use two people to transport the appliance.

During first use:

- ▶ Transport the appliance packaged.

When transporting appliances after initial commissioning (e. g. moving or cleaning):

- ▶ Empty the appliance.
- ▶ Secure the door against unintentional opening.

4.4 Unpacking appliance

- ▶ Check the appliance and the packaging for damage during transport. Contact the supplier immediately if you suspect any damage. Do not connect appliance to the power supply.
- ▶ Remove all packaging materials from the rear or the side walls of the fridge that may prevent proper installation or prevent air flow and ventilation.

4.5 Removing transport lock

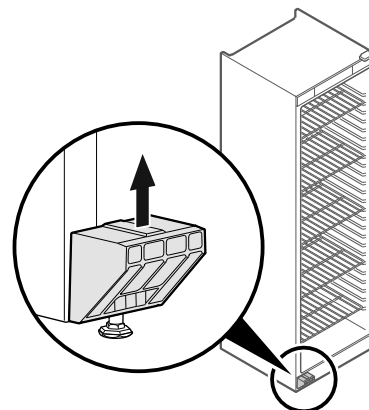

Fig. 8

- ▶ Remove transport lock in upwards direction.
- ▷ Base holder remains on the appliance.

4.6 Installing door handle

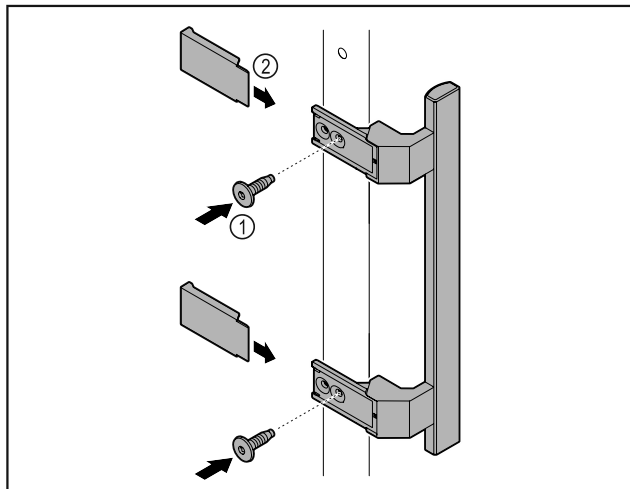

Fig. 9

- ▶ Attach handle from accessory kit to the door using the screws Fig. 9 (1) supplied.
- ▶ Put on cover Fig. 9 (2).

4.7 Mounting anti-tipping device

Tools



Fig. 10



WARNING

Danger of injury and damage due to appliance tipping over!
 Danger to life and material damage to appliance. If you remove fully loaded shelves from the appliance, the appliance may tip over.

- ▶ Before putting the appliance into operation: install anti-tipping device in accordance with the instructions.

Prevent appliance from tipping over.

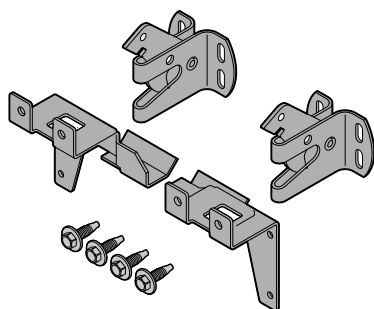

Fig. 11

The anti-tilt device is included with the device. It consists of two retaining parts, two securing hooks and four self-tapping screws (4 x 14).

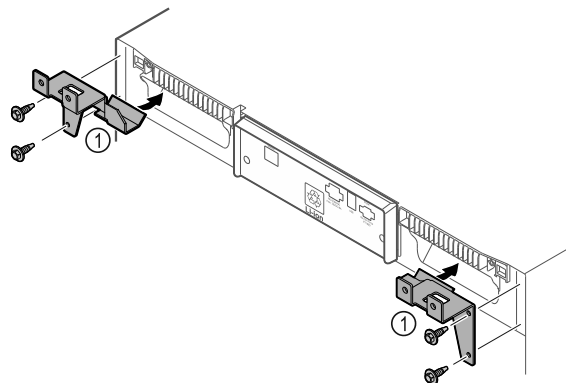

Fig. 12

- ▶ Fit the retaining parts Fig. 12 (1) to the device with self-tapping screws.
- ▶ Push appliance with retaining parts mounted against the wall.

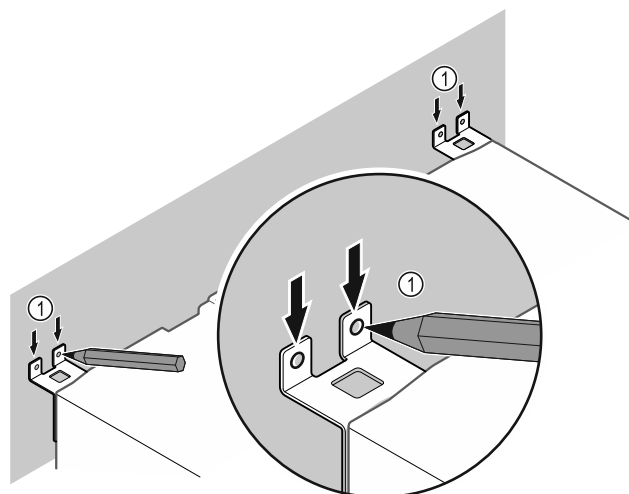

Fig. 13

- ▶ Make markings on the wall Fig. 13 (1).
- ▶ Remove appliance.

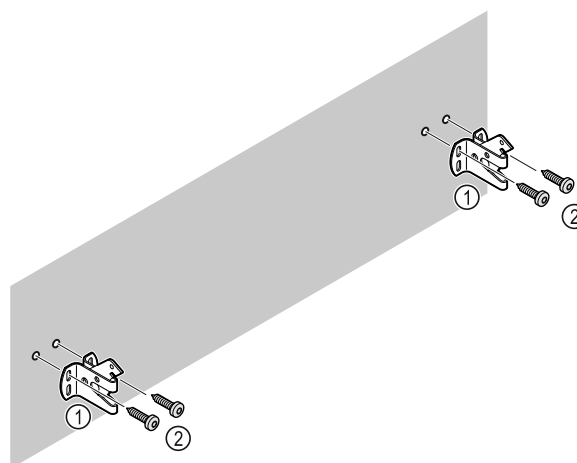

Fig. 14

Use fixing material (e.g. dowels) which is appropriate for the nature of the wall (wood, concrete) and sufficient attachment points.

- ▶ Attach retaining hooks.

Putting into operation

4.8 Installing appliance



CAUTION

Risk of injury and damage.

- ▶ Use 2 people to install appliance.



CAUTION

Risk of injury and damage.

The door can knock against the wall and become damaged as a result. In the case of glass doors, the damaged glass can cause injuries.

- ▶ Protect the door from knocking against the wall. Attach door stopper, e.g. felt stopper, to the wall.

- ▶ Connect all necessary components (e.g. mains cable) to the back of the appliance and route to the side.

Note

Cables can be damaged.

- ▶ Do not jam the cable when pushing the appliance back.

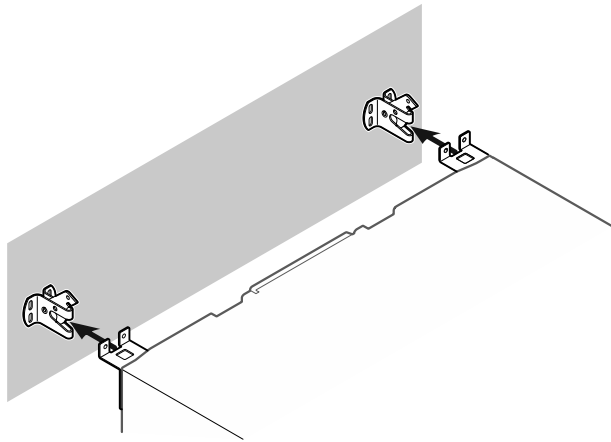

Fig. 15

- ▶ Slide appliance up against the wall so that the retaining parts latch into the securing hooks.
- ▷ The appliance is now secured against tipping.
- ▷ It can be released by folding back the securing hooks.

4.9 Setting up the appliance so it is level

NOTICE

Appliance body is deformed and door does not close.

- ▶ Align appliance horizontally and vertically.
- ▶ Compensate for uneven floors using adjustable feet.



WARNING

Incorrect height adjustment of the adjustable foot!

Can cause severe or even fatal injury. Incorrect height adjustment can cause the bottom part of the adjustable foot to come loose and the appliance to tip over.

- ▶ Do not unscrew the adjustable foot too far.

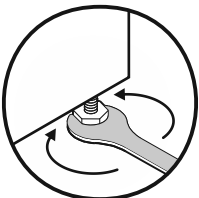

Fig. 16

Raising appliance:

- ▶ Turn adjustable foot clockwise.

Lowering appliance:

- ▶ Turn adjustable foot anticlockwise.

4.10 Installing multiple appliances

NOTICE

Risk of damage due to condensation between the side walls.

- ▶ Do not install the appliance directly next to another fridge.

- ▶ Install appliances with a space 3 cm between appliances.

- ▶ Only install multiple appliances up to temperatures of 35 °C and 65% humidity next to one another.

- ▶ At higher levels of humidity, increase space between appliances.

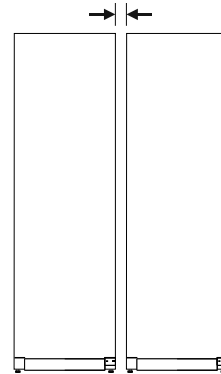

Fig. 17 Side-by-side installation

Note

A side-by-side kit is available as an accessory via Liebherr Customer Service. (see 9.3 Customer Service)

4.11 After installation

- ▶ Peel off the protective films. *
- ▶ Clean appliance. (see 8.3 Cleaning the appliance)
- ▶ If necessary: Disinfect the appliance.
- ▶ Keep the invoice so you have the appliance and dealer information available if needed.

4.12 Disposing of packaging



WARNING

Danger of suffocation due to packing material and plastic film!

- ▶ Do not allow children to play with packing material.

The packaging is made of recyclable materials:

- corrugated board/cardboard
- expanded polystyrene parts
- polythene bags and sheets
- polypropylene straps
- nailed wooden frame with polyethylene panel*

- ▶ Take the packaging material to an official collecting point.

4.13 Reversing the door opening direction

Tools

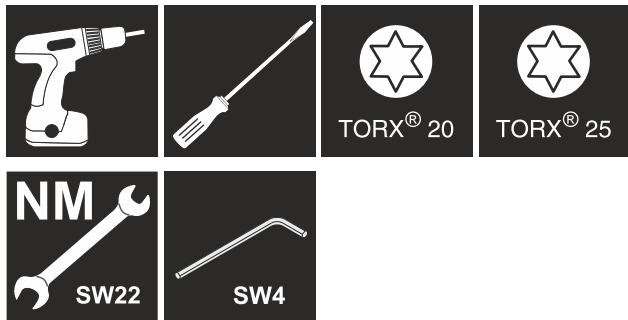

WARNING

- Risk of injury if the door is not reversed correctly!
- ▶ The door may only be reversed by qualified personnel.



WARNING

- Risk of injury and material damage due to heavy door!
- ▶ Only perform the conversion if you can carry a weight of 25 kg.
 - ▶ Always have someone help you carry out the conversion.

NOTICE

- Live parts!
Damage to electrical components.
- ▶ Disconnect the power plug before reversing the door.

- ▶ Open the door.

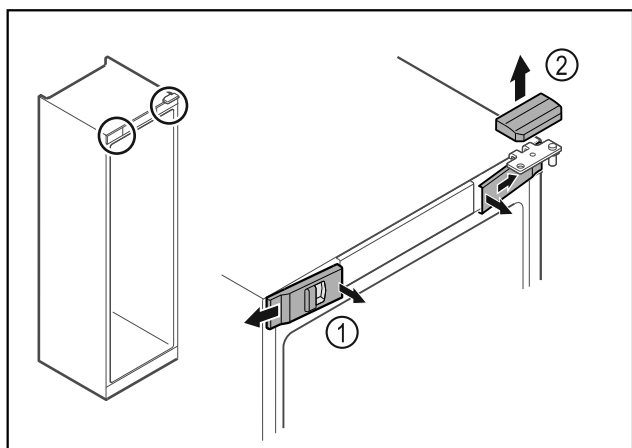

Fig. 18

- ▶ Unlatch the front covers Fig. 18 (1) on the inside and remove them sideways.
- ▶ Lift off the upper cover Fig. 18 (2).

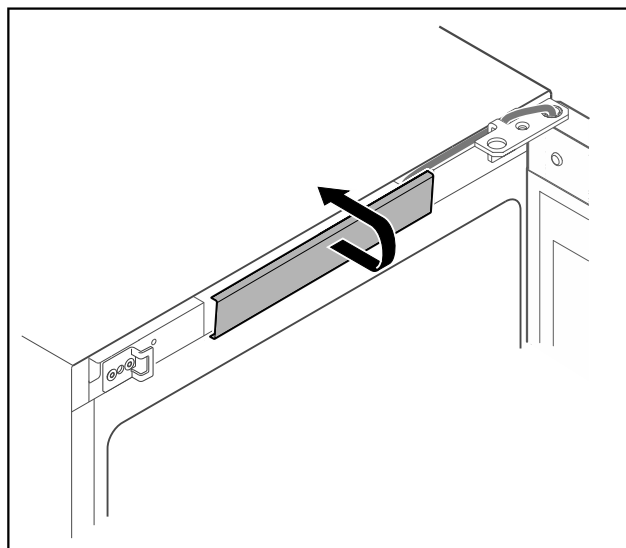

Fig. 19

- ▶ Unlatch the middle cover and remove it.

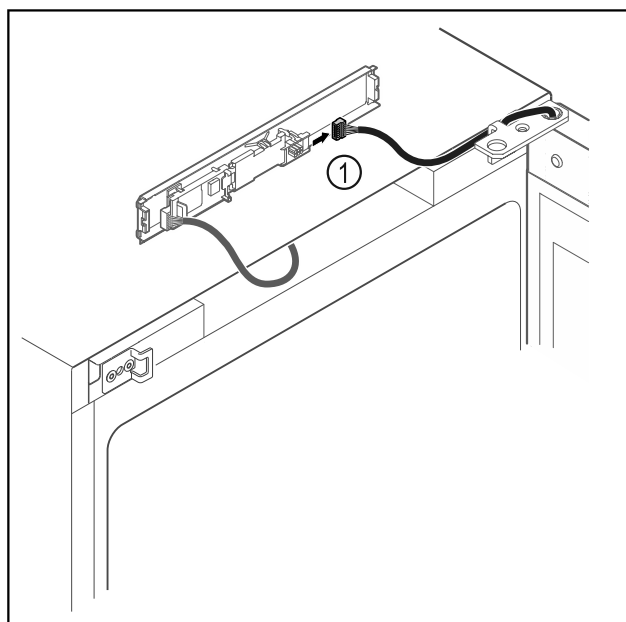

Fig. 20

- ▶ Disconnect the plug Fig. 20 (1) from the circuit board.

Putting into operation

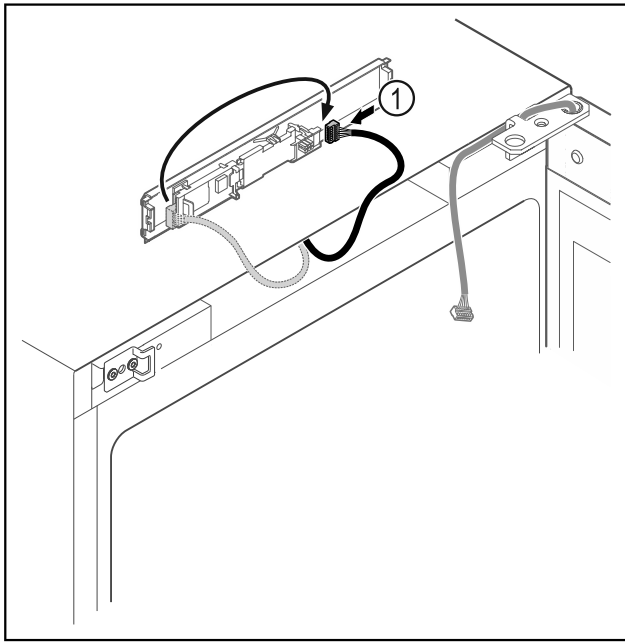

Fig. 21

- ▶ Connect the plug Fig. 21 (1) to the circuit board.

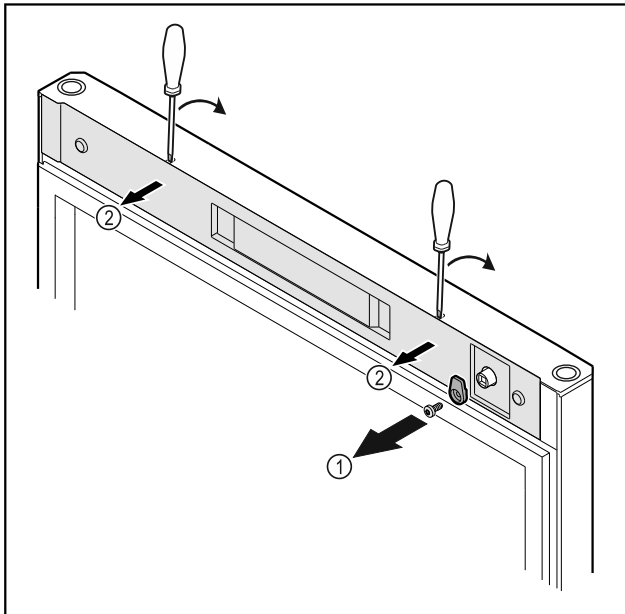

Fig. 22

- ▶ Unscrew the door latch Fig. 22 (1).
- ▶ Unlatch the cover Fig. 22 (2) with a small screwdriver and remove it.

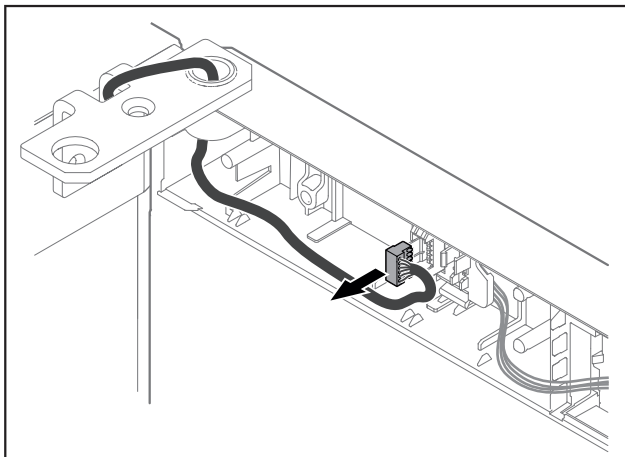

Fig. 23

- ▶ Remove the plug from the plug holder.

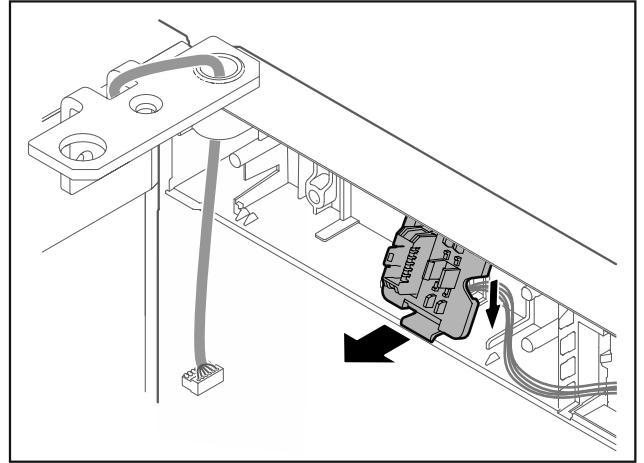

Fig. 24 The installation position of the plug holder can be rotated by 180°.

- ▶ Disengage the plug holder.

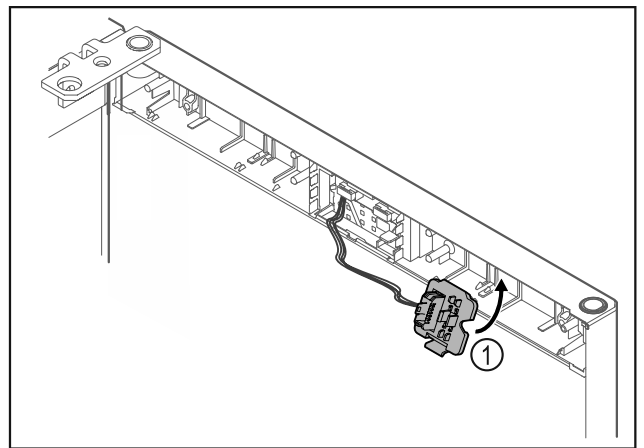

Fig. 25

- ▶ Snap in the plug holder Fig. 25 (1) on the opposite side.

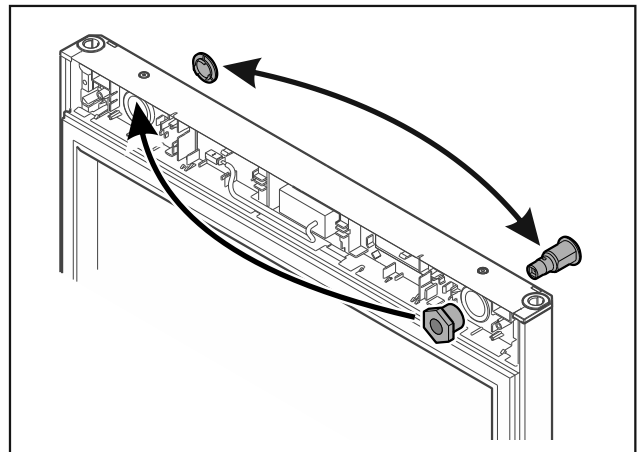

Fig. 26

- ▶ Put the lock and cover on the opposite side.

NOTICE

Risk of injury if the door tips out!

- ▶ Hold the door.

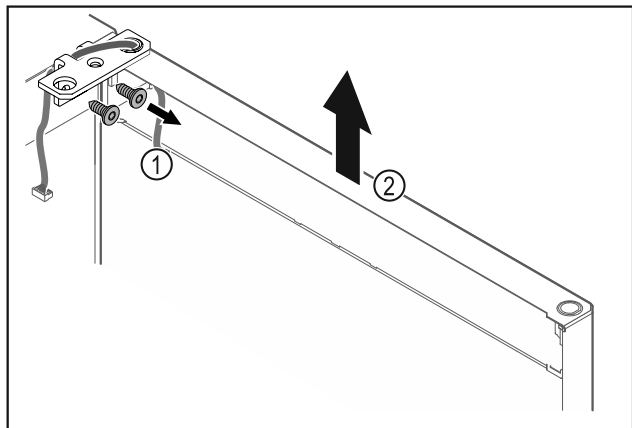

Fig. 27

- ▶ Unscrew the hinge Fig. 27 (1).
- ▶ Lift the door with the hinge straight up by Fig. 27 (2) roughly 200 mm and take it off.
- ▶ Carefully place the door on a soft surface.

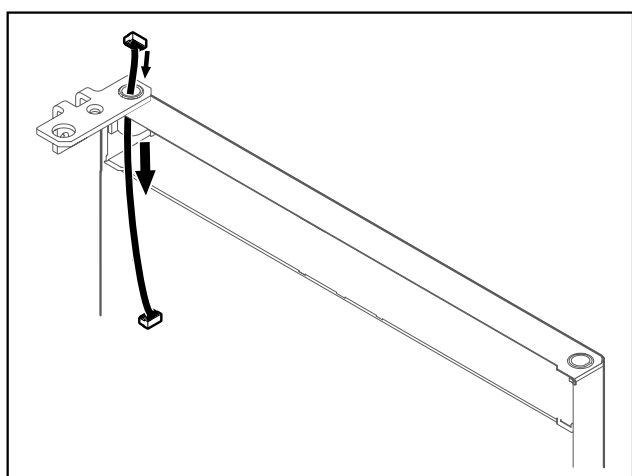

Fig. 28

- ▶ Carefully pull out the cable.

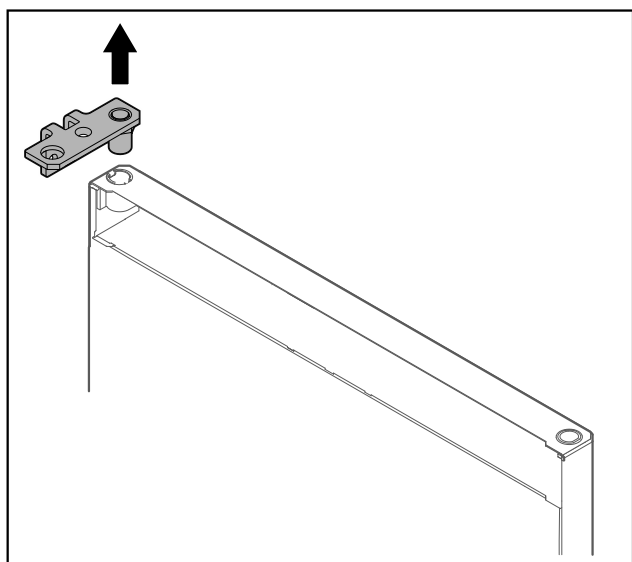

Fig. 29

- ▶ Pull out the hinge.

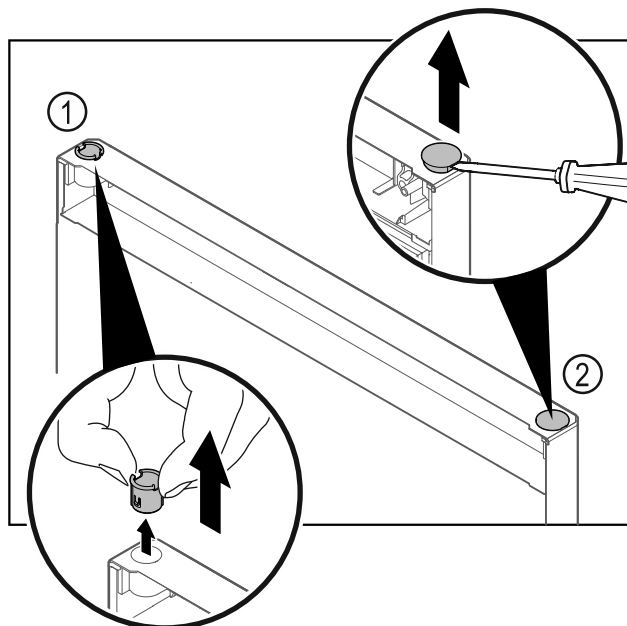

Fig. 30

- ▶ Pull out the hinge bushing Fig. 30 (1) with your fingers.
- ▶ Carefully lift the cover plug Fig. 30 (2) with a slotted screwdriver and pull it out.

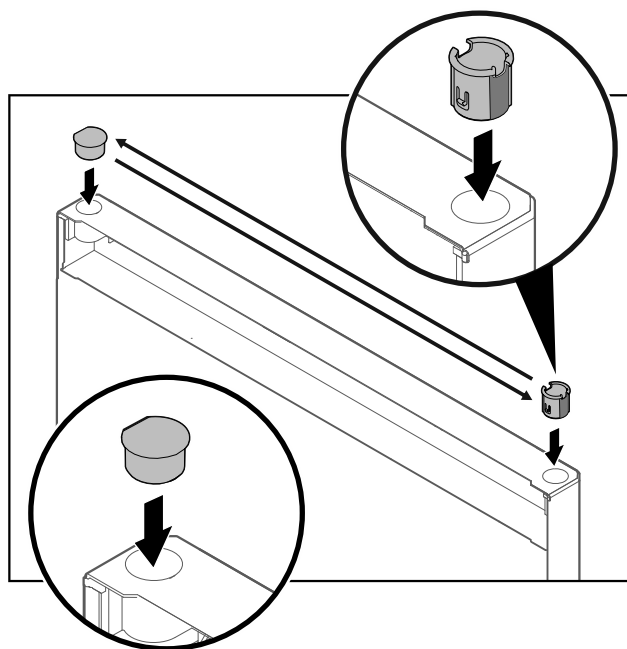

Fig. 31

- ▶ Insert hinge bushing and cover plug on the opposite side (the flattened sides face outwards).

Putting into operation

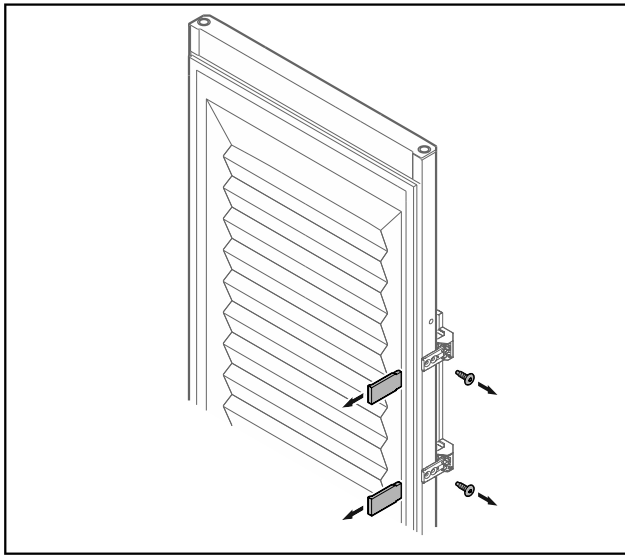

Fig. 32 Insulated door

- ▶ Remove the panels.
- ▶ Unscrew the handle.

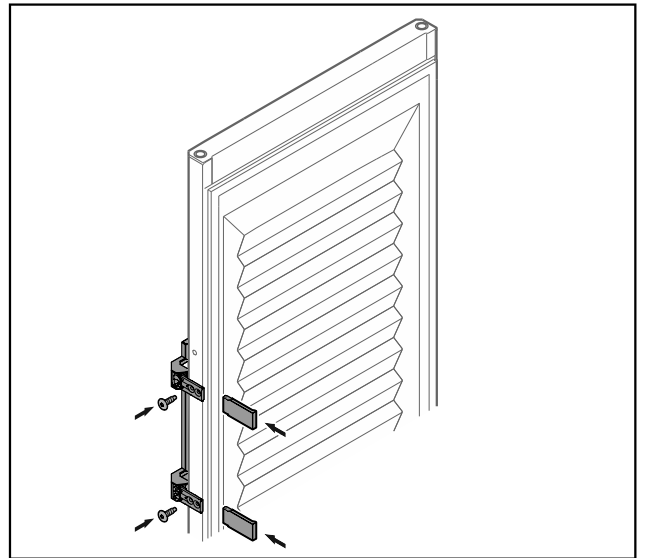

Fig. 34 Insulated door

- ▶ Screw the handle onto the opposite side.
- ▶ Attach the panels.

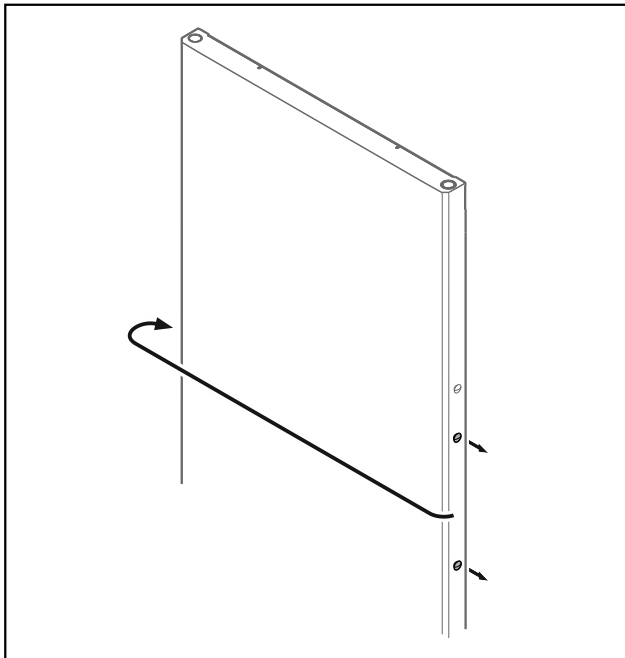

Fig. 33

- ▶ Put the stopper on the opposite side.

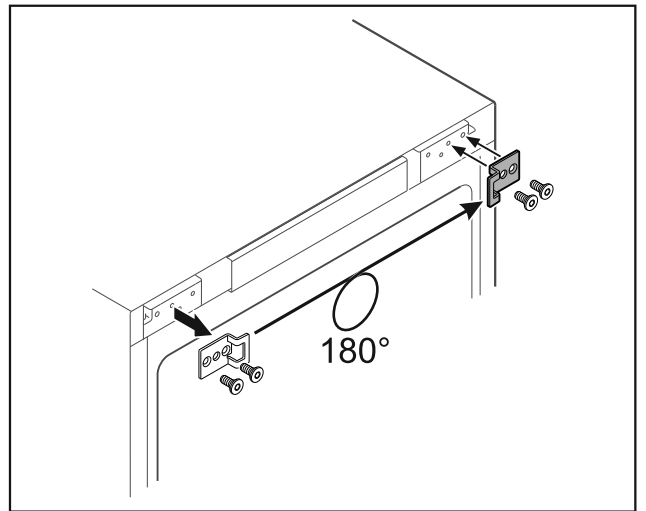

Fig. 35

- ▶ Put the closing bracket on the opposite side.

Note

The holes are pre-marked and must be pierced with the self-tapping screws.

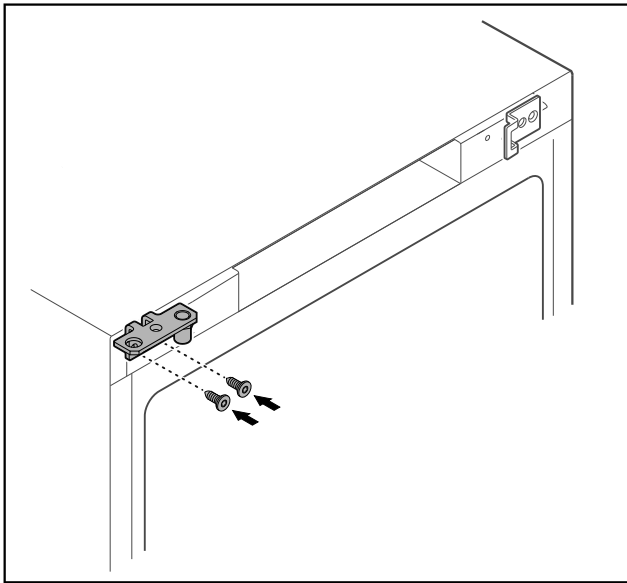

Fig. 36

- ▶ Move the hinge to the opposite side.



WARNING

Risk of injury and material damage if the door tips out!

- ▶ Tighten the bearing pins to the specified torque.

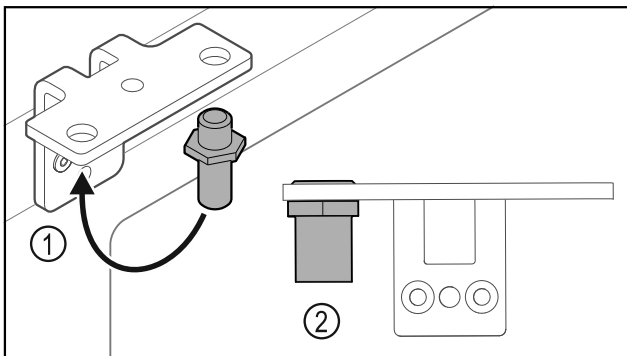

Fig. 37

- ▶ Put the pin back into the hinge Fig. 37 (1).
- ▶ Tighten the pin Fig. 37 (2) to a **torque of 12 Nm**.
- ▶ Unscrew the hinge again.

NOTICE

Risk of injury due to tensioned spring!

- ▶ Do not disassemble the door closing system Fig. 38 (1).

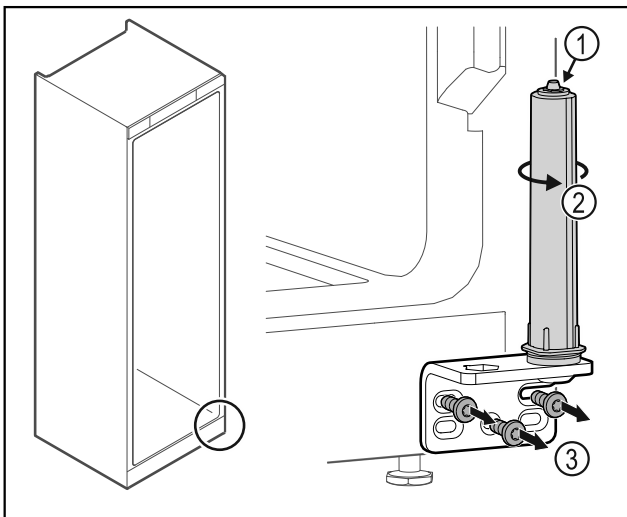

Fig. 38

- ▶ Turn the closing system Fig. 38 (2) until it clicks.
- ▶ The tension of the closing system is released.
- ▶ Unscrew the hinge Fig. 38 (3).

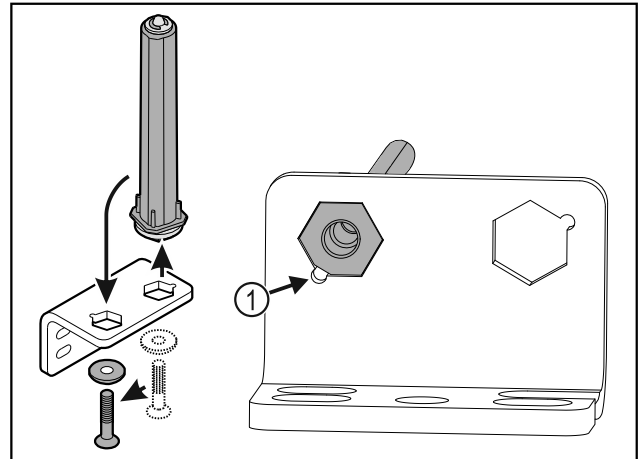

Fig. 39

- ▶ Put the door closing system in the hinge.
- ▶ Make sure the pin chamfer Fig. 39 (1) faces the round hole when you put it in.

-or-

Note

Incorrect alignment of the height adjustment washers. Nuts no longer have sufficient hold.

- ▶ The washer must lock into the underside of the closing system.

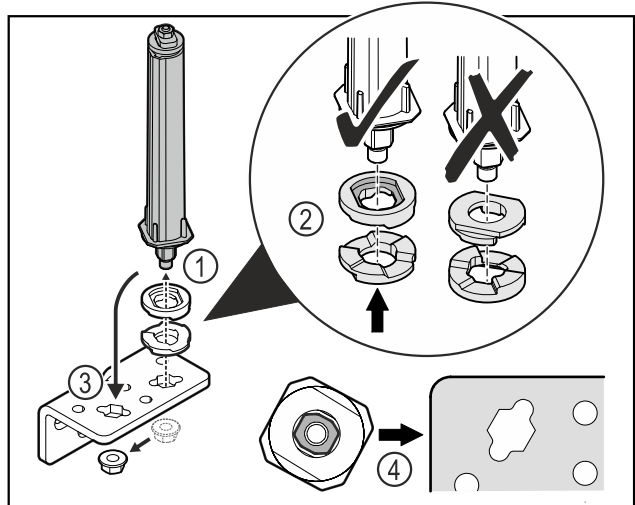

Fig. 40

- ▶ Loosen the nut and remove the door closing system Fig. 40 (1).
- ▶ Observe the correct alignment of the height adjustment washers Fig. 40 (2).
- ▶ Put the door closing system in the hinge and fix in place with the nut Fig. 40 (3).
- ▶ Observe the correct alignment of the door closing system when doing so Fig. 40 (4).

Putting into operation

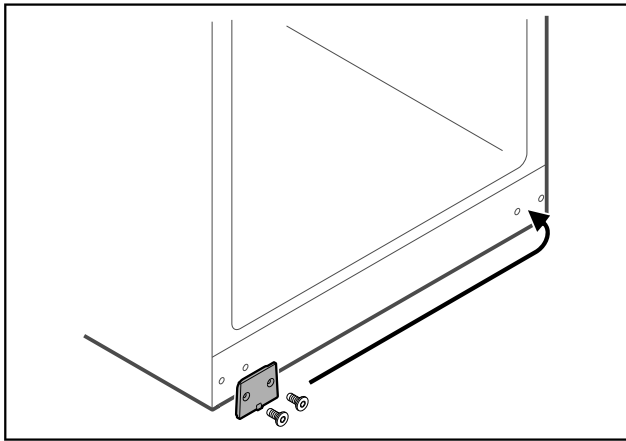

Fig. 41

- Put the cover plate on the opposite side.

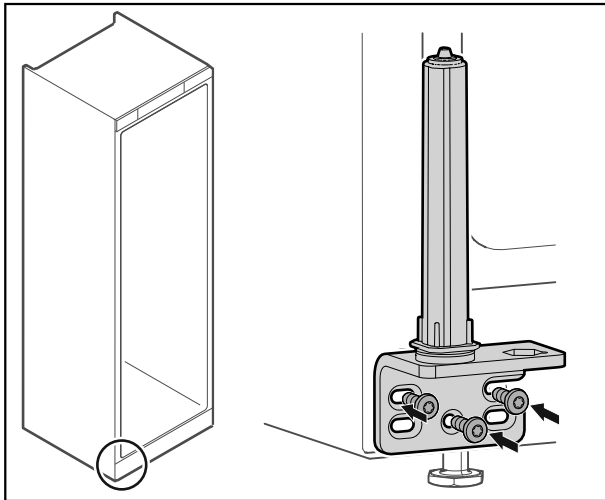

Fig. 42

- Screw the hinge onto the opposite side.

Note

Correct alignment and tension are important for the closing system to work properly.

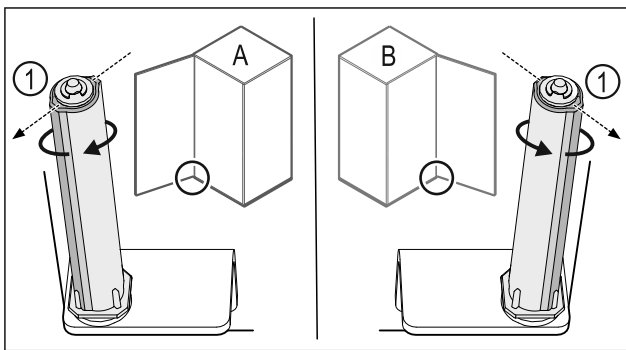

Fig. 43 Left-hinged (A) / Right-hinged (B)

- Turn the closing system against the resistance until the bar of the closing system Fig. 43 (1) points outwards.
- ▷ The closing system automatically stays in this position.
- ▷ The closing system is now aligned and tensioned.

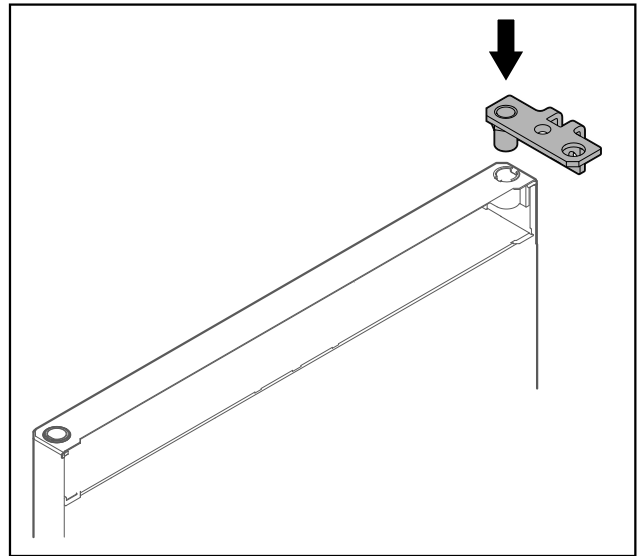

Fig. 44

- Put the hinge into the door.

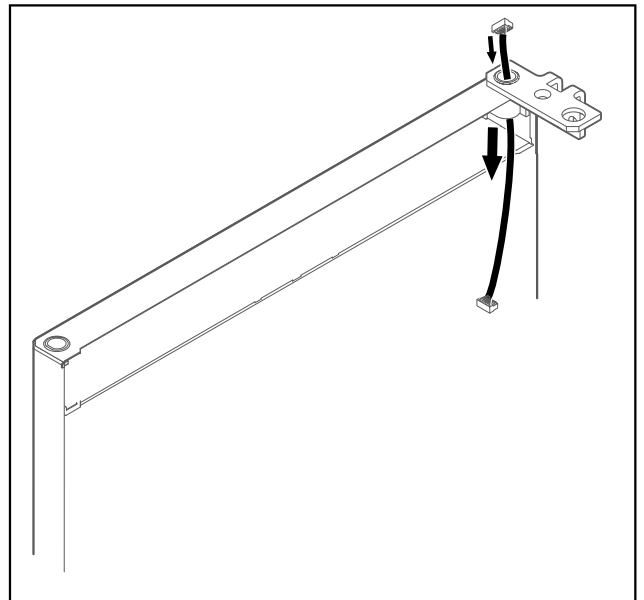

Fig. 45

- Carefully push the cable through.

NOTICE

Risk of injury if the door tips out!

- Hold the door.

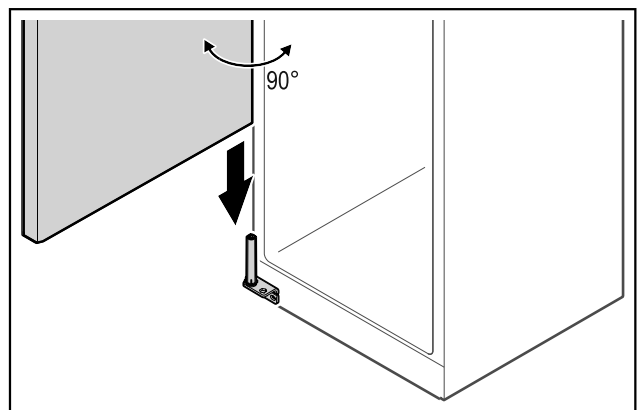

Fig. 46

- Together with a second person, lift the door from the ground.

- ▶ Carefully put the door on the closing system with the door opened at a 90° angle.

NOTICE

Material damage due to incorrect mounting!

- ▶ Do not pinch the cable when mounting the hinge.

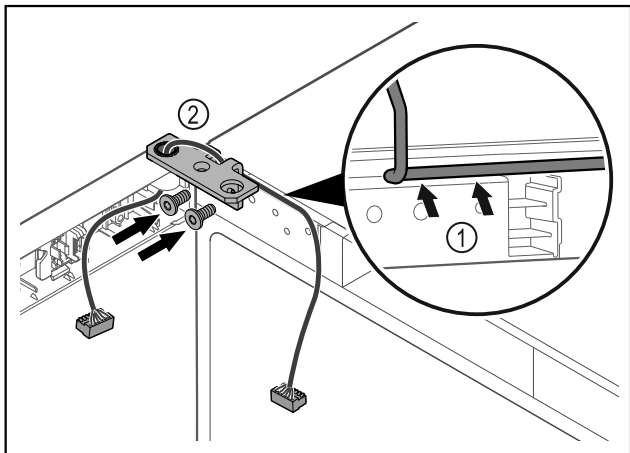

Fig. 47

- ▶ Feed the cable through the recess in the hinge and lay it carefully Fig. 47 (1).
- ▶ Screw on the hinge Fig. 47 (2).

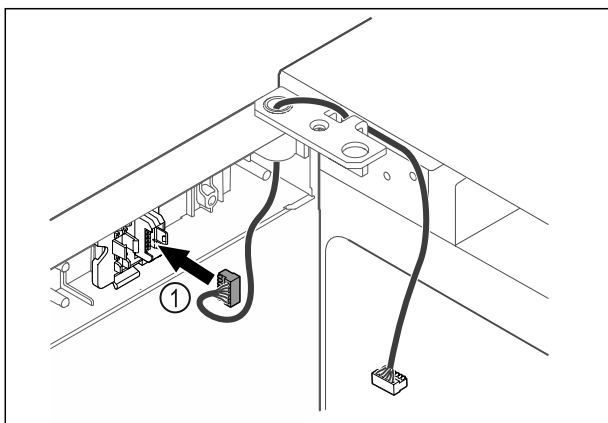

Fig. 48

- ▶ Put the plug Fig. 48 (1) in the plug holder.

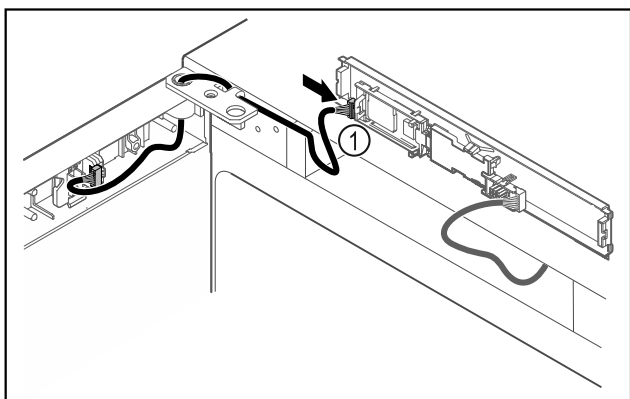

Fig. 49

- ▶ Connect the plug Fig. 49 (1) to the circuit board.

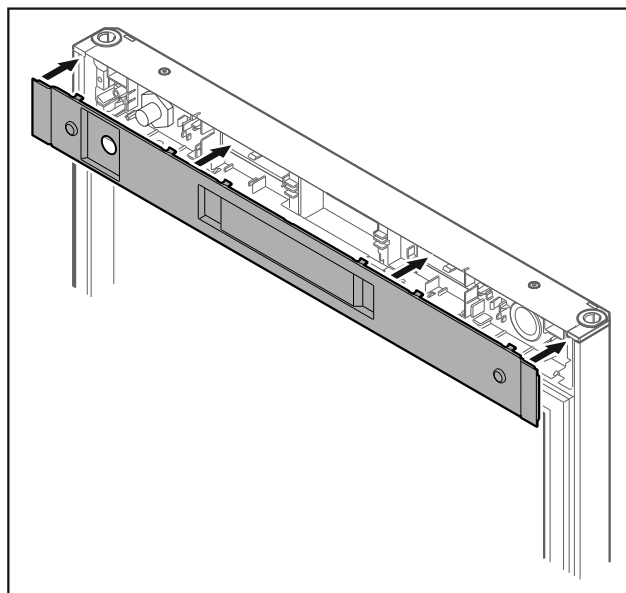

Fig. 50

- ▶ Set the cover back in place.

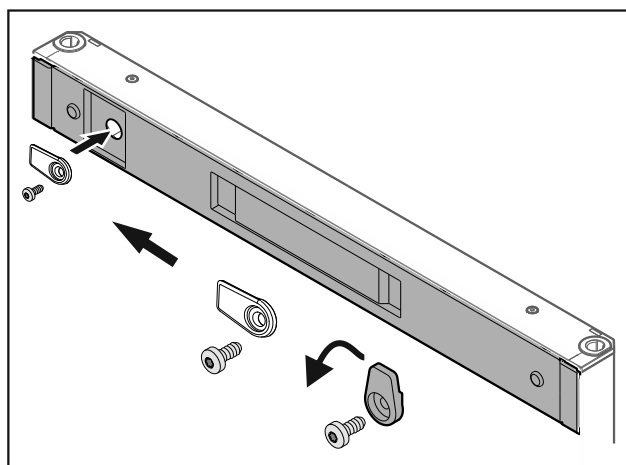

Fig. 51

- ▶ Screw on the door latch.

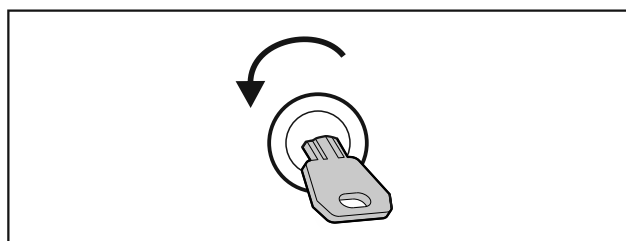

Fig. 52

- ▶ Open the door.

Putting into operation

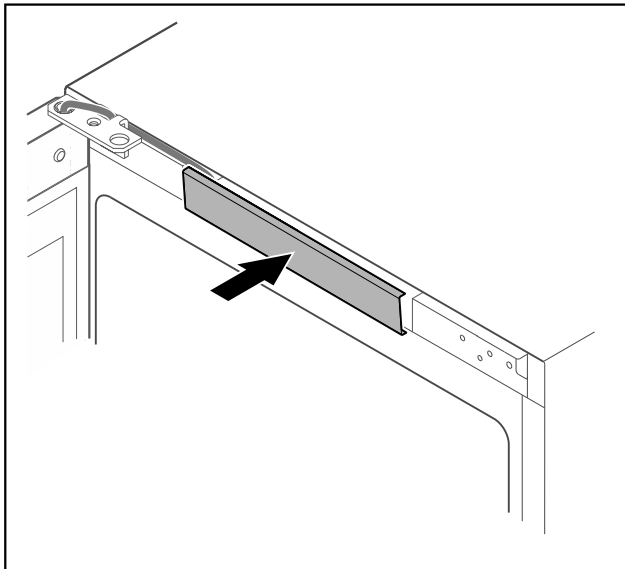

Fig. 53

- ▶ Snap in the middle cover.

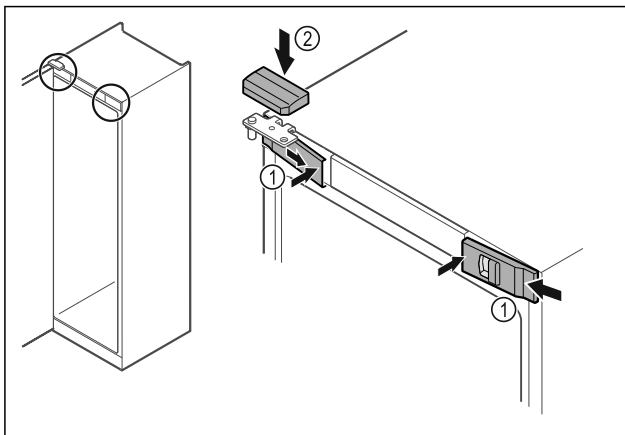

Fig. 54

- ▶ Hook in the front covers Fig. 54 (1) on the side and snap them into place on the inside.
- ▶ Snap on the top cover Fig. 54 (2) from above.
- ▶ Close the door.
- ▷ The door has now been reversed.

4.14 Aligning the door

If the door is not straight, you can adjust it on the lower hinge.

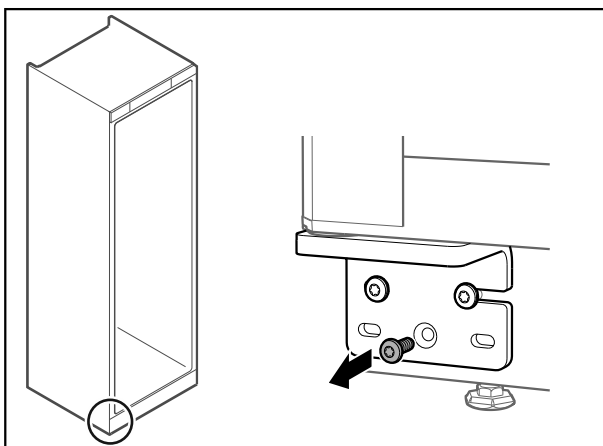

Fig. 55

- ▶ Remove the middle screw on the lower hinge.

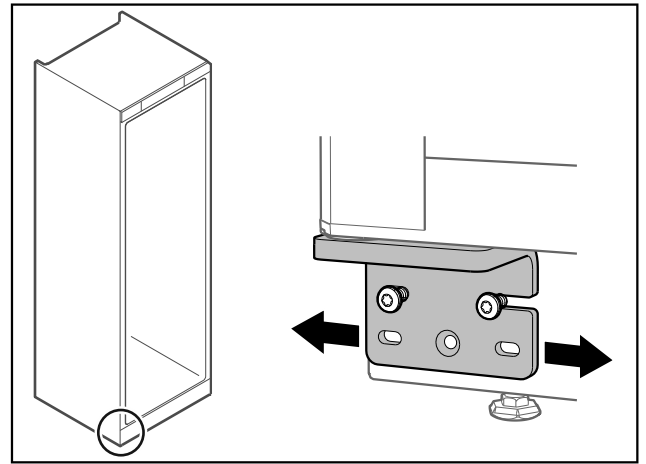

Fig. 56

- ▶ Slightly undo both screws and move the door with the hinge to the left or right.
- ▶ Fully tighten the screws (the middle screw is no longer needed).
- ▷ The door is now straight.

4.15 Connecting appliance



WARNING

Danger of fire due to incorrect connection!
Burns.

Damage to the appliance.

- ▶ Do not use an extension cable.
- ▶ Do not use distributor blocks.

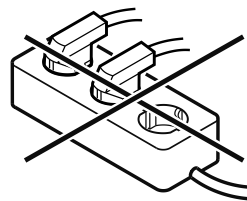

NOTICE

Danger of damage to incorrect connection!

Damage to the appliance.

- ▶ Do not connect the appliance to a stand-alone inverter, e.g. solar power systems and petrol generators.

Note

Only use the supplied mains cable.

Make sure that the following requirements are fulfilled:

- The appliance operated using **alternating current** only.
- The permitted voltage and frequency is printed on the type plate. The type plate position can be seen in the appliance overview chapter. (see 1.2 Overview of appliance and equipment)
- The socket is earthed according to the regulations and fused.
- The fuse tripping current is between 10 A and 16 A.
- The socket is easily accessible.
- ▶ Check the electrical connection.
- ▶ Insert the appliance plug into the back of the appliance. Ensure that they latch into place.
- ▶ Connect the mains plug to the power supply.
- ▷ The display switches to the standby symbol.

4.16 Switching on appliance (first use)

Make sure the following prerequisites are met:

- Appliance is installed and connected.
- All adhesive strips, adhesive and protective films and transport locks are removed from inside and outside the appliance.

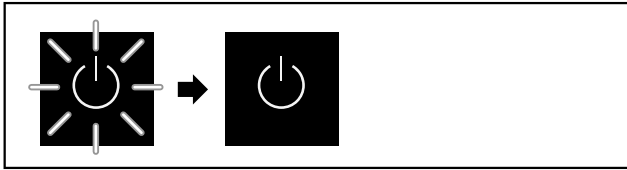

Fig. 57 Example illustration

The standby symbol flashes until the startup process is complete.

The standby symbol is shown in the display.

If the appliance has been supplied with factory settings, the screen language first needs to be selected when using for the first time.

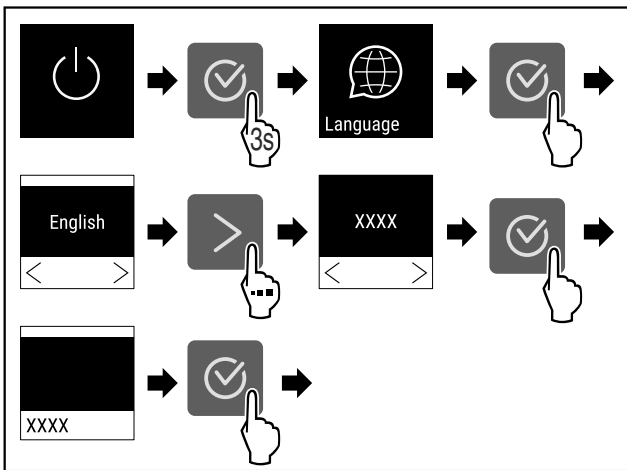

Fig. 58

- Carry out action steps according to the illustration.

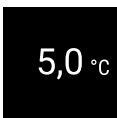

Fig. 59

- ▷ The appliance is switched on once the temperature appears in the display.
- ▷ The temperature display flashes until the set temperature is reached.

5 Storage

5.1 Information regarding storage

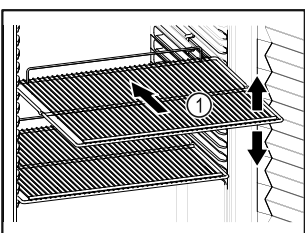

Fig. 60 Example illustration

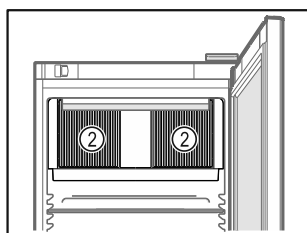



Fig. 61

When stocking observe the following:

- If there are adjustable shelves Fig. 60 (1), position them as required.
- Observe maximum load weight. (see 9.1 Technical specifications)
- Do not load appliance until storage temperature has been reached (maintain cold chain).
- Ventilation slots Fig. 61 (2) for recirculation fan in the interior must be kept clear.
- Refrigerated goods must not touch the rear wall.
- Do not store refrigerated goods beyond the rear stop of the support grates.
- Keep liquids in closed containers.
- Leave space when storing items for refrigeration to ensure good air circulation.
- Do not stack refrigerated products above the indicated height. 
- This is important for free air circulation and even temperature distribution in the interior.
- Do not store refrigerated goods under the defrost water bowl.

6 Controls

6.1 Appliance functions

6.1.1 Notes on the appliance functions

The appliance functions are set at the factory so that your appliance is fully functional.

Before you alter, activate or deactivate the device functions, make sure that the following requirements are met:

- You have read and understood the descriptions of how the display works.
- You have familiarised yourself with the operating and display elements of your appliance.

6.1.2 Switching appliance on and off

Using this setting the entire appliance can be switched on and off.

Switching on appliance

Without activated DemoMode:



Fig. 62

- Carry out action steps according to the illustration.

With activated DemoMode:

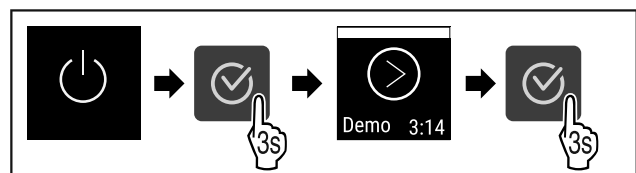

Fig. 63

- Carry out action steps according to the illustration.

Note

Deactivate DemoMode before countdown finishes.

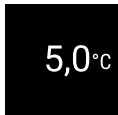

Fig. 64

▷ The temperature appears in the display.

Switching off appliance

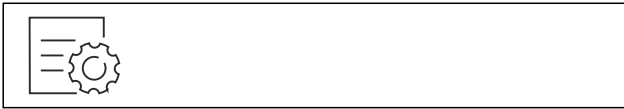

Fig. 65

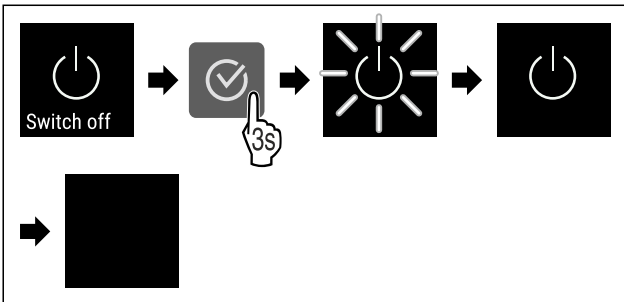

Fig. 66

- ▶ Carry out action steps according to the illustration.
- ▷ Standby symbol is shown in the display.
- ▷ Display switches off after approximately 10 minutes.

6.1.3 Temperature



The temperature depends on the following factors:

- How often the door is opened
- How long the door is open for
- The room temperature of the installation site
- The type, temperature and amount of refrigerated items

Note

The temperature may differ from the temperature displayed in some areas of the interior.

Setting temperature



Fig. 67

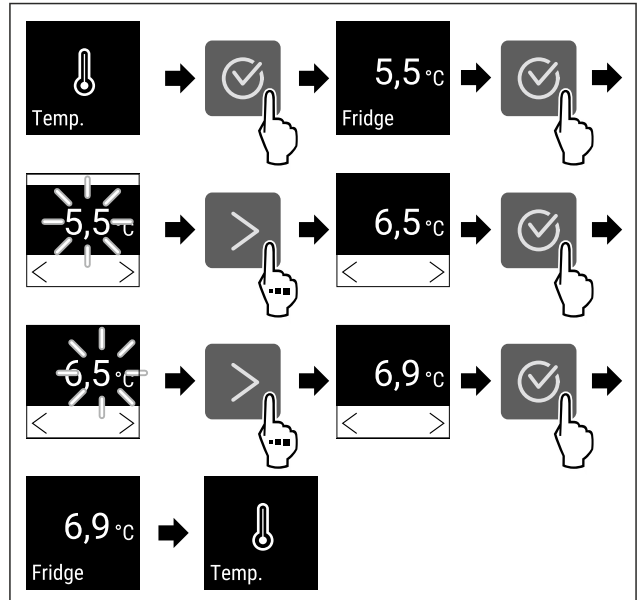

Fig. 68 Changing temperature from 5.5 °C to 6.9 °C

- ▶ Carry out action steps according to the illustration.
- ▷ Temperature is set.

6.1.4 Temperature recording



The appliance displays the minimum and maximum temperatures of the interior. The recording of these temperatures starts automatically after the appliance is switched on; they are recorded at one minute intervals. A note indicating that the data memory is full is displayed after 999 hours (approx. 40 days). The temperature recording should then be reset.

Note

We recommend resetting the temperature recording once **after reaching the set temperature** when the appliance is commissioned. This ensures that the value displayed for the maximum temperature is a meaningful value.

Displaying temperature recording

The temperature recording displays the length of the recording and the minimum and maximum temperatures measured during this period of time.



Fig. 69



Fig. 70

- ▷ Status screen with the temperature recordings is displayed.

Resetting temperature recording

The displayed minimum and maximum temperatures can be reset at any time. This deletes the displayed values and the recording interval starts again.

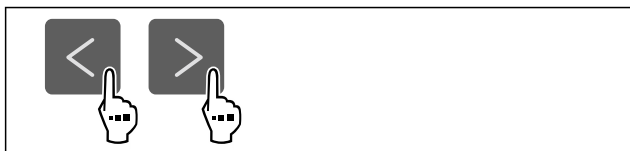

Fig. 71

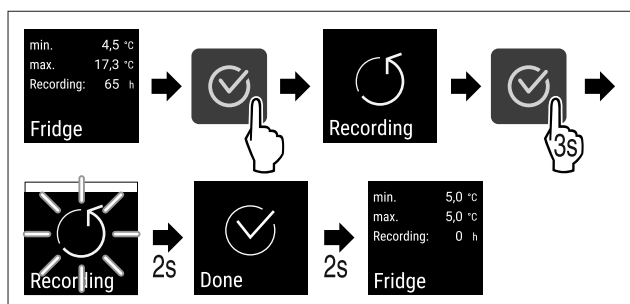

Fig. 72

- ▶ Carry out steps according to the illustration.
- ▷ Temperature recording is reset.
- ▷ Recording interval starts again.

6.1.5 Settings menu access protection



This setting enables the settings menu access protection via a three-digit PIN code.

Application:

- Prevent settings and functions being changed unintentionally.
- Prevent appliance being switched off unintentionally.
- Avoid unintentional temperature adjustment.

Activating the settings menu access protection



Fig. 73

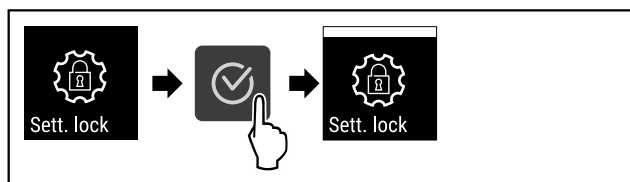

Fig. 74

- ▶ Carry out action steps according to the illustration.
- ▷ Settings menu access protection is activated.

Changing the access protection PIN code for the settings menu

See: (see 6.1.6 Access code)

Deactivating the settings menu access protection



Fig. 75

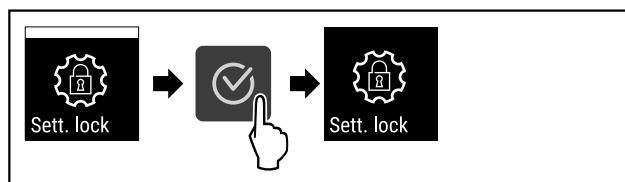

Fig. 76

- ▶ Carry out action steps according to the illustration.
- ▷ Settings menu access protection is deactivated.

Opening protected settings menu

If the access protection is active, it is necessary to enter the PIN code to open the settings menu.

After entering the correct PIN code, the settings menu remains unlocked for 20 minutes unless you jump back to the status display.

Note

- ▶ In the following example, the factory-set PIN code: **1 1 1** is used.

- ▶ **Access protection for the settings menu must be active.**
- ▶ Tap navigation arrow repeatedly until corresponding function is displayed.

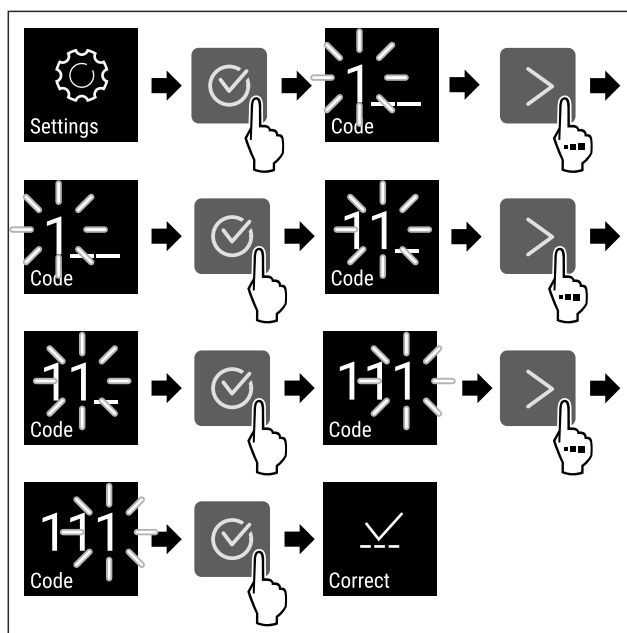

Fig. 77

- ▶ Carry out action steps according to the illustration.
- ▷ The PIN code is correct.
- ▷ The settings menu opens.

6.1.6 Access code

Various settings are possible.

Application:

- Changing the settings code.
- Resetting the settings code.

Settings menu access protection



Changing the settings code

This setting allows the settings code for settings menu access protection to be changed.

The setting is made in 3 stages:

- Entering the old settings code

Controls

- Entering the new settings code
- Confirming the new settings code

Note

- ▶ In the following example, the default factory-set settings code **1 1 1** is changed.
- ▶ The new settings code is: **2 3 4**



Fig. 78

The access protection for the settings menu must be active. (see 6.1.5 Settings menu access protection)

- ▶ Tap the navigation arrow repeatedly until the corresponding function is displayed.

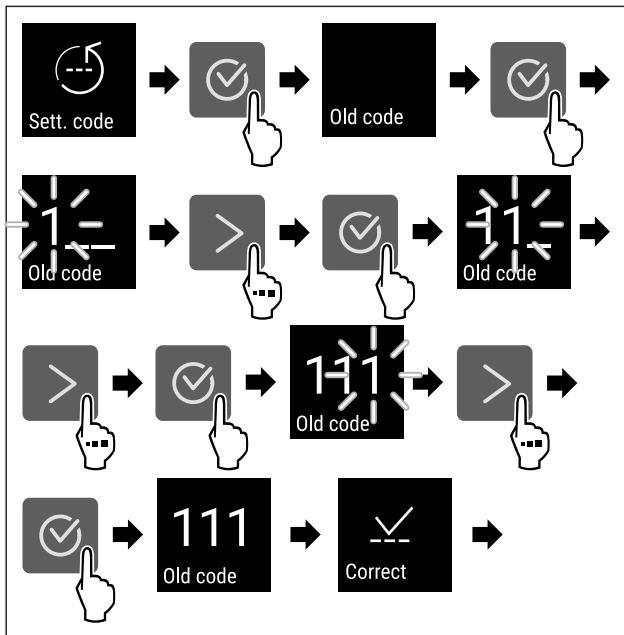

Fig. 79

- ▶ Carry out action steps according to the illustration.
- ▷ Entry of the old settings code successful.

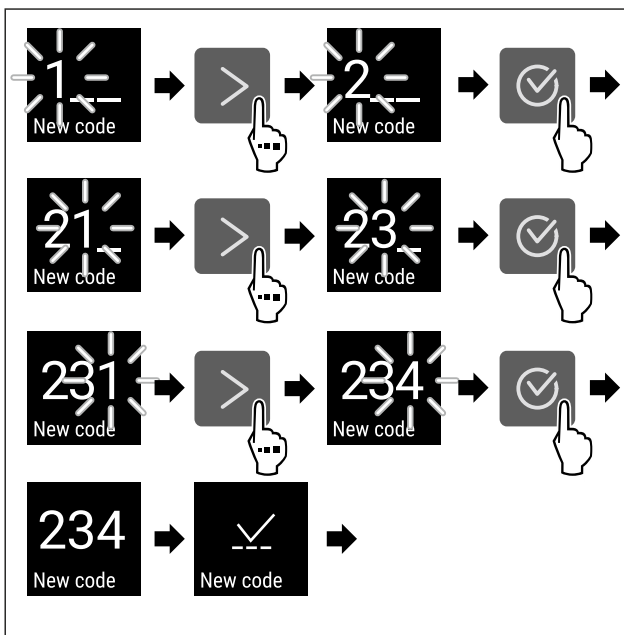

Fig. 80

- ▶ Carry out action steps according to the illustration.
- ▷ Entry of the new settings code successful.

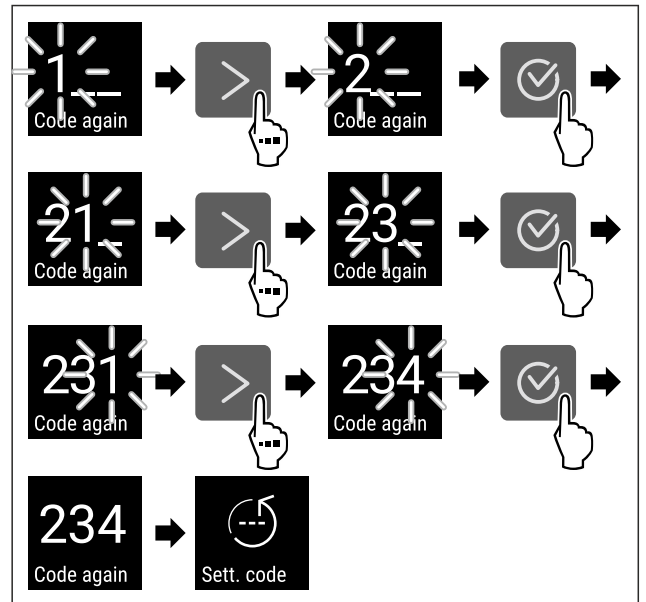

Fig. 81

- ▶ Carry out action steps according to the illustration.
- ▷ Confirmation of the new settings code successful.
- ▷ The settings code has been changed.

Resetting the settings code

The settings code for the settings menu access protection has been forgotten or is not known.

- ▶ Reset appliance to factory settings (see 6.1.25 Resetting to factory settings).
- ▷ The appliance is reset to the original settings.
- ▷ The factory-set settings code is: **1 1 1**

6.1.7 Maintenance interval reminder



Setting for the time interval after which a maintenance reminder is issued.

The following values can be set:

- 7 days
- 14 days
- 30 days
- 60 days
- 90 days
- 180 days
- 360 days
- 720 days
- 1080 days
- Off

Setting maintenance interval reminder

The following steps describe how the maintenance interval is set.



Fig. 82

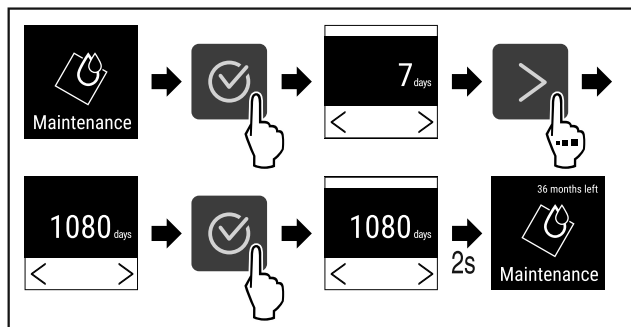

Fig. 83

- ▶ Carry out action steps according to the illustration.
- ▷ The time interval, after which the maintenance reminder is issued, is set.
- ▷ The remaining time is displayed.

6.1.8 Language



This setting allows the display language to be set.

Setting language



Fig. 84

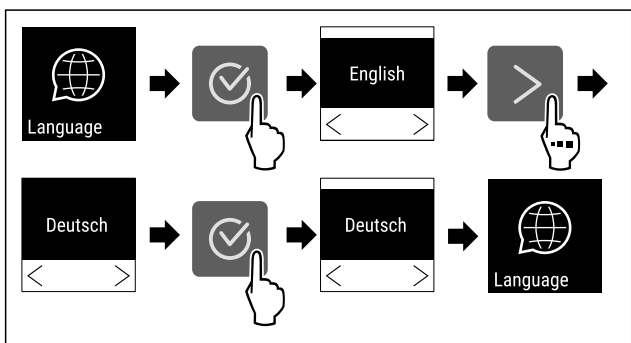

Fig. 85

- ▶ Carry out action steps according to the illustration.
- ▷ The selected language is set.

6.1.9 Temperature unit



Use this function to set the temperature unit. You can set degrees Celsius or degrees Fahrenheit as the temperature unit.

Setting the temperature unit



Fig. 86

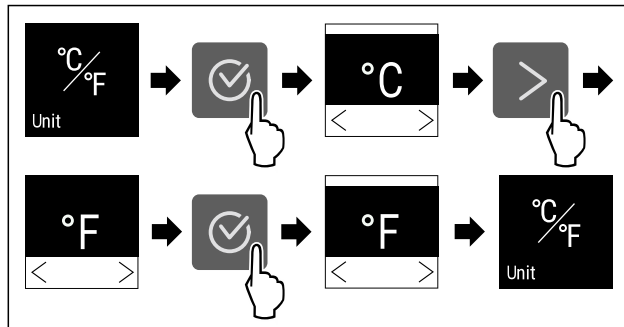

Fig. 87 Example illustration: Switch from degrees Celsius to degrees Fahrenheit.

- ▶ Carry out action steps according to the illustration.
- ▷ The temperature unit is set.

6.1.10 Display brightness



Use this function to set the display brightness in stages.

You can select the following brightness levels:

- 40 %
- 60 %
- 80 %
- 100 % (pre-setting)

Setting the display brightness



Fig. 88

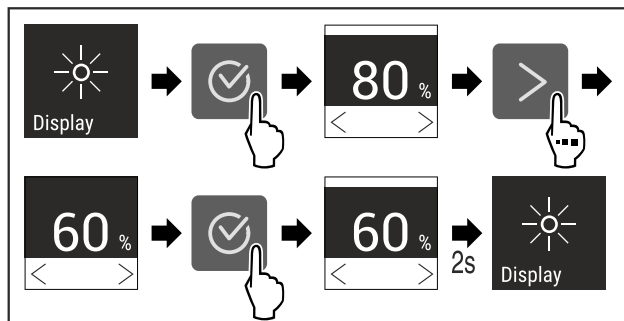

Fig. 89 Example illustration: Switch from 80 % to 60 %.

- ▶ Carry out action steps according to the illustration.
- ▷ The display brightness is set.

6.1.11 Alarm Sound



This function enables all alarm sounds, such as door alarm, to be switched on and off.

Activating Alarm Sound



Fig. 90

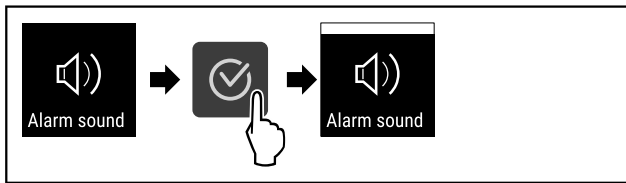

Fig. 91

- ▶ Carry out action steps according to the illustration.
- ▷ Alarm Sound is activated.

Deactivating Alarm Sound



Fig. 92

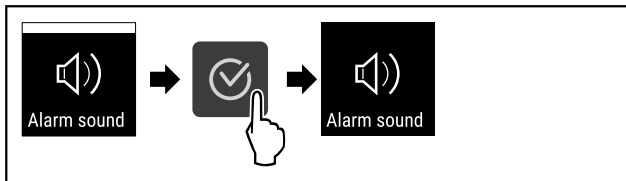

Fig. 93

- ▶ Carry out action steps according to the illustration.
- ▷ Alarm Sound is deactivated.

6.1.12 Key Sound

This function makes it possible to switch all confirmation sounds and the Startsound on and off.

Activating Key Sound



Fig. 94

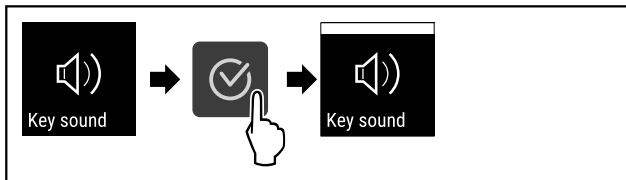

Fig. 95

- ▶ Carry out action steps according to the illustration.
- ▷ Key Sound is activated.

Deactivating Key Sound



Fig. 96

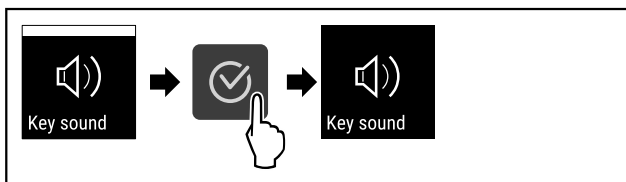

Fig. 97

- ▶ Carry out action steps according to the illustration.
- ▷ Key Sound is deactivated.

6.1.13 WiFi connection

Note

Liebherr SmartMonitoring Dashboard is not available in all countries. Check availability via the QR code by entering your model.

Note

Use of the Liebherr SmartMonitoring Dashboard at <https://smartmonitoring.liebherr.com> requires installation of a SmartModule and a commercial MyLiebherr account. When commissioning online you can register using the login data you have, or register again and create a company account.

This setting establishes a wireless connection between the appliance and the internet. The connection is controlled via the SmartModule. The appliance can be integrated via the browser-based [Liebherr SmartMonitoring Dashboard](#) and advanced options as well as customised methods relating to control, administration and monitoring can be used.

Note

Accessories are available from Customer Service (see 9.3 Customer Service) and the Liebherr-Hausgeräte store at home.liebherr.com/shop/de/deu/zubehor.html.

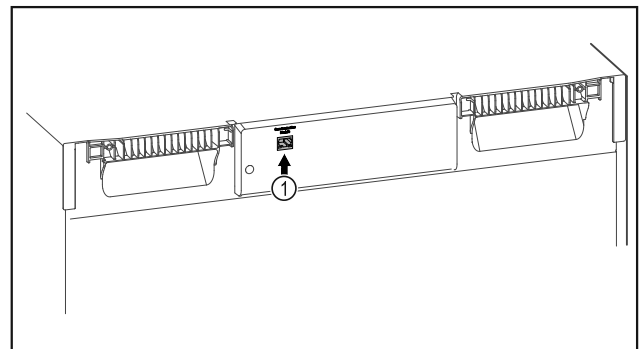

Fig. 98

- Make sure that the following requirements are fulfilled:
- SmartModule Fig. 98 (1) is in use.

Establishing connection

You commission and set up your SmartModule online via the [Liebherr SmartMonitoring Dashboard](#) on your web-enabled device.

On the [Liebherr SmartMonitoring Dashboard](#), information is also available about retrofitting the SmartModule.



Fig. 99

- ▶ Open the [Liebherr SmartMonitoring Dashboard](#) (see Fig. 99).

On the refrigerator or freezer:

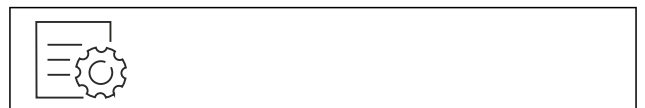

Fig. 100

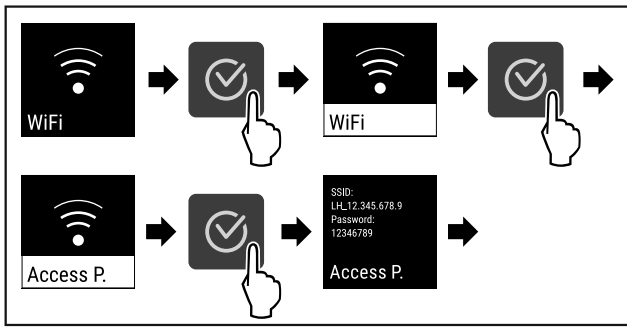

Fig. 101

- ▶ Carry out action steps according to the illustration.
- ▶ Continue the set-up procedure on your web-enabled device: [Liebherr SmartMonitoring Dashboard](#)

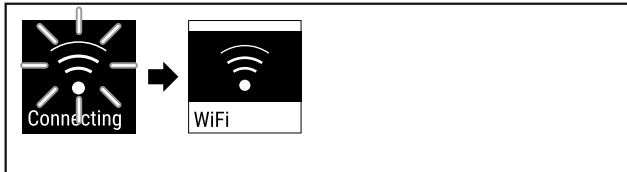

Fig. 102

- ▶ Connection is established.
- ▷ WiFi connecting appears. The symbol flashes.
- ▶ Follow the [Liebherr SmartMonitoring Dashboard](#) instructions.
- ▷ Connection is established.

Disconnecting



Fig. 103

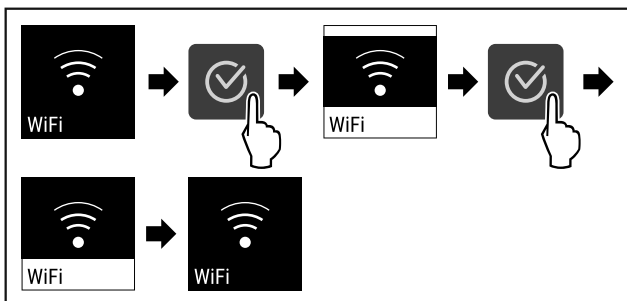

Fig. 104

- ▶ Carry out action steps according to the illustration.
- ▷ There is no connection.

Resetting connection



Fig. 105

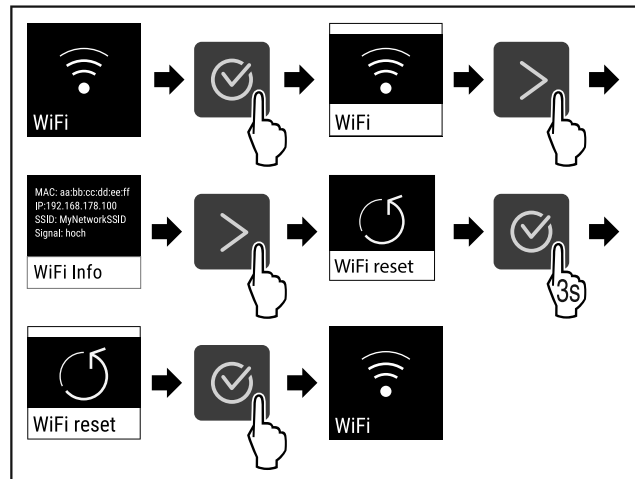

Fig. 106

- ▶ Carry out action steps according to the illustration.
- ▷ The WiFi settings are restored to the factory settings.



6.1.14 LAN connection

Note

Liebherr SmartMonitoring Dashboard is not available in all countries. Check availability via the QR code by entering your model.

Note

Use of the Liebherr SmartMonitoring Dashboard at <https://smartmonitoring.liebherr.com> requires installation of a SmartModule and a commercial MyLiebherr account. When commissioning online you can register using the login data you have, or register again and create a company account.

This setting establishes a wired connection between the appliance and the internet. The connection is controlled via the SmartModule. The appliance can be integrated via the browser-based [Liebherr SmartMonitoring Dashboard](#) and advanced options as well as customised methods relating to control, administration and monitoring can be used.

Note

Accessories are available from Customer Service (see 9.3 Customer Service) and the Liebherr-Hausgeräte store at home.liebherr.com/shop/de/deu/zubehor.html.

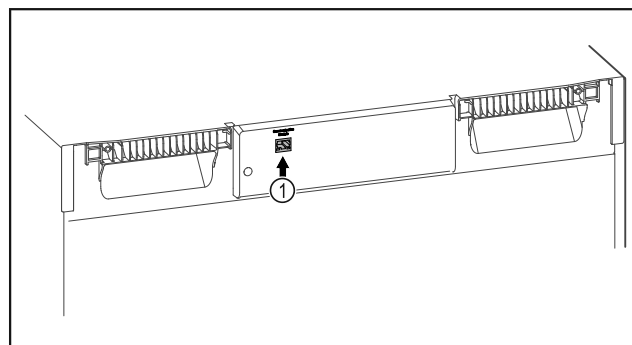

Fig. 107

Make sure that the following requirements are fulfilled:

- SmartModule Fig. 107 (1) is in use.
- A network cable is connected.

Controls

Establishing connection

You commission and set up your SmartModule online via the [Liebherr SmartMonitoring Dashboard](#) on your web-enabled device.

On the [Liebherr SmartMonitoring Dashboard](#), information is also available about retrofitting the SmartModule.



Fig. 108

- ▶ Open the [Liebherr SmartMonitoring Dashboard](#) (see Fig. 108).

On the refrigerator or freezer:



Fig. 109

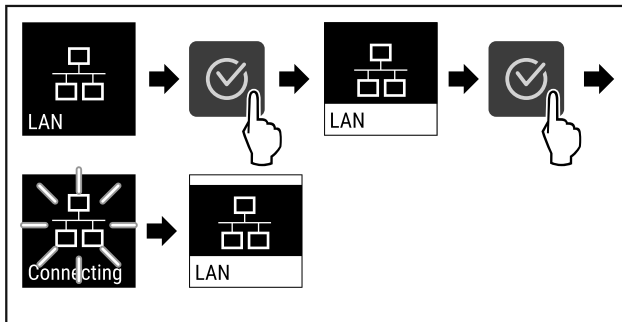

Fig. 110

- ▶ Carry out action steps according to the illustration.
- ▷ Connection is established: LAN connecting appears. The symbol flashes.
- ▶ Follow the [Liebherr SmartMonitoring Dashboard](#) instructions.
- ▷ Connection is established.

Disconnecting



Fig. 111

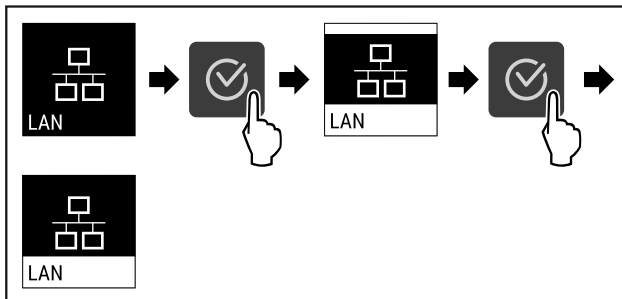

Fig. 112

- ▶ Carry out action steps according to the illustration.
- ▷ There is no connection.

6.1.15 Device information



Use this function to indicate the model name, index, serial number and service number of your device. You will need the device information when you contact customer service. (see 9.3 Customer Service)

This function also opens the Advanced menu. (see 3 Functionality of the Touch display)

Indicating the device information



Fig. 113



Fig. 114

- ▶ Carry out action steps according to the illustration.
- ▷ Display indicates device information.

6.1.16 Operating hours



The display shows the appliance operating hours.

Displaying operating hours



Fig. 115



Fig. 116

- ▷ The operating hours appear.

6.1.17 Software



Use this function to indicate the software version of your device.

Indicating the software version



Fig. 117



Fig. 118

- ▶ Carry out action steps according to the illustration.
- ▷ Display indicates software version.

6.1.18 Defrosting



The appliance defrosts automatically in normal mode.

Application:

- If there is excessive ice in the interior, the defrosting function can be started manually.

Manually starting automatic defrosting



Fig. 119

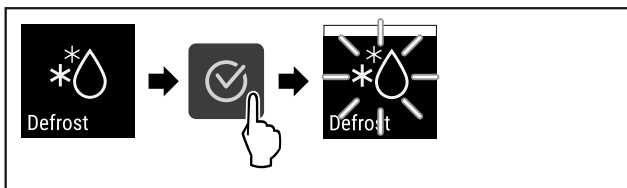

Fig. 120

- ▶ Carry out action steps according to the illustration.
- ▷ Automatic defrosting has been started. The appliance automatically switches back to normal mode once defrosting has finished.

Note

If there is still ice in the interior after starting automatic defrosting several times, defrost the appliance manually. (see 8.2 Defrosting appliance)

Cancelling manually started defrosting



Fig. 121

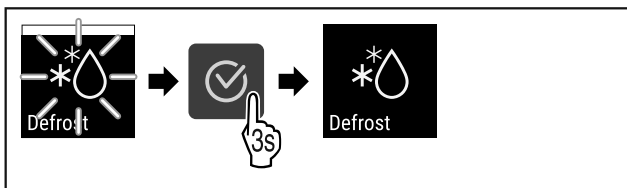

Fig. 122

- ▶ Carry out action steps according to the illustration.
- ▷ Manually started defrosting is cancelled. The appliance automatically switches back to normal mode.

Defrosting info



This setting adjusts the display during an automatic defrosting process.

The following display variants are available:

- **Def 1:** The temperature display is not updated and shows the last temperature before the automatic defrosting process started.

- **Def 2:** “Automatic defrosting” notice is indicated on the status display. The temperature display is continuously updated and shows the actual temperature.
- **Def 3:** “Automatic defrosting” notice is indicated on the status display. The temperature display is not updated and shows the last temperature before the automatic defrosting process started.
- **Def 4:** “Automatic defrosting” notice is indicated on the status display. The temperature display is not updated and shows the last temperature before the automatic defrosting process started.

Defrosting

Fig. 123 “Automatic defrosting process” note



Fig. 124

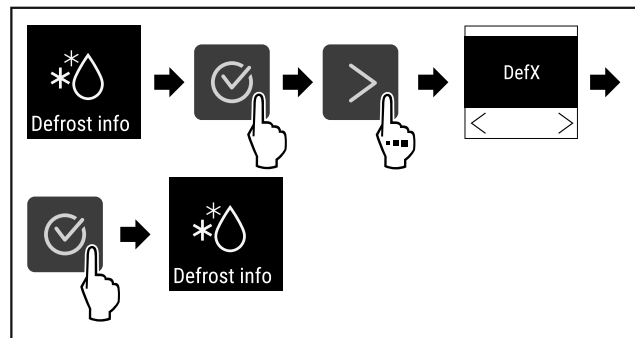

Fig. 125

- ▶ Carry out action steps according to the illustration.
- ▷ The desired display variant has been selected.

6.1.19 Sensor calibration



The sensor calibration is used to realign differences between the displayed temperature and the actual temperature in the appliance.

Setting range: +/- 3 Kelvin in 0.1 Kelvin increments.

Calibrating the sensor

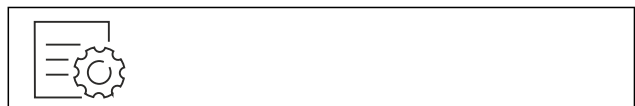

Fig. 126

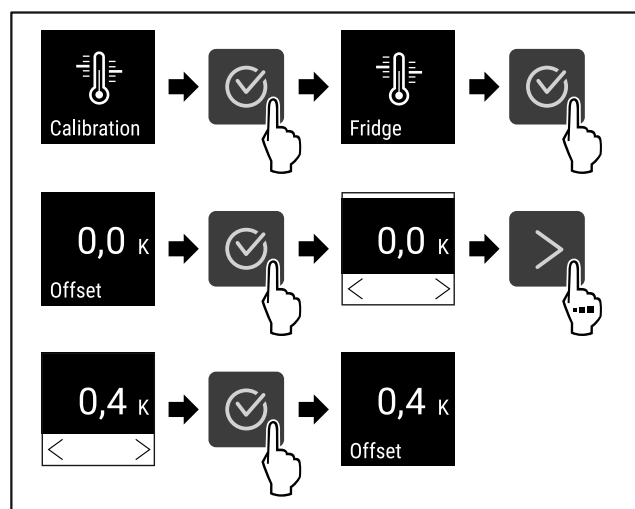

Fig. 127

Controls

- ▶ Carry out action steps according to the illustration.
- ▷ The sensor is calibrated.

Note

The calibrated temperature is indicated on the display within two hours.

6.1.20 Temperature alarm

The temperature alarm is triggered as soon as the interior temperature differs from the adjustable temperature range and any set delay time has elapsed.

The following values can be set:

- Lower temperature limit in 0.1 °C increments
- Upper temperature limit in 0.1 °C increments
- Alarm delay time from 0 to 60 minutes (setting "0" means no alarm repetition at the alarm relay.)
- Alarm repetition frequency of between 0 and 30 minutes

Setting temperature alarm

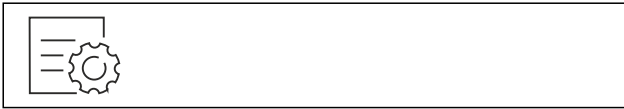

Fig. 128

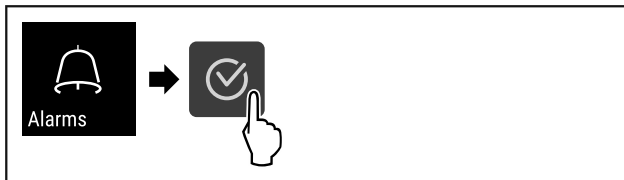

Fig. 129

- ▶ Carry out action steps according to the illustration.



Fig. 130

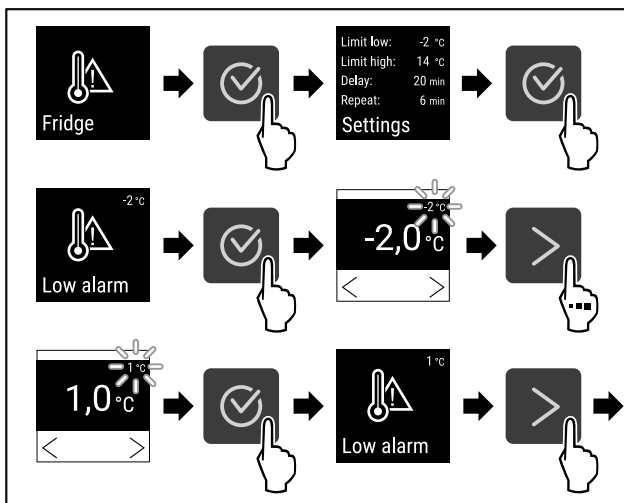

Fig. 131

- ▶ Carry out action steps according to the illustration.
- ▷ Lower temperature limit has been set.

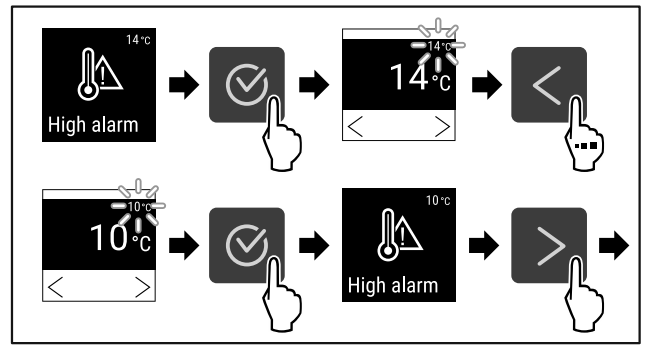

Fig. 132

- ▶ Carry out action steps according to the illustration.
- ▷ Upper temperature limit has been set.

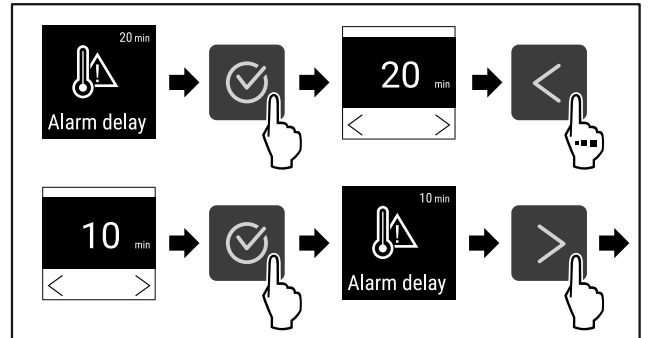

Fig. 133

- ▶ Carry out action steps according to the illustration.
- ▷ Alarm delay time has been set.

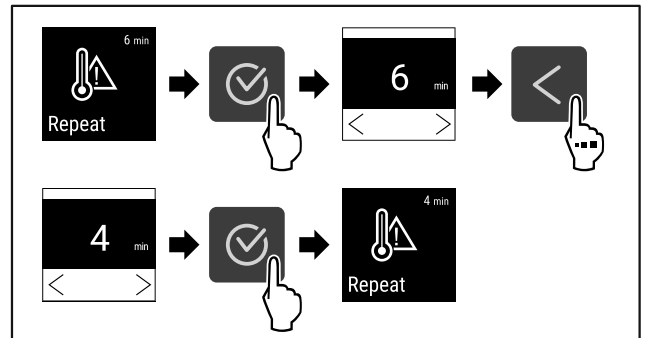

Fig. 134

- ▶ Carry out action steps according to the illustration.
- ▷ Alarm repetition interval has been set.
- ▷ Temperature alarm has been set.

Displaying set temperature alarm values

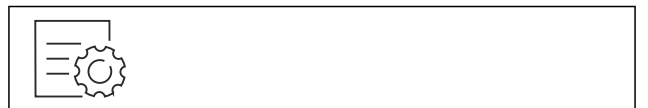

Fig. 135



Fig. 136

- ▶ Carry out action steps according to the illustration.

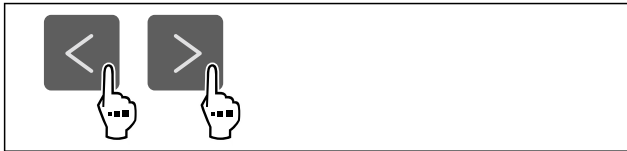

Fig. 137

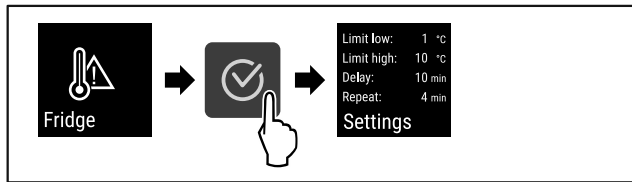

Fig. 138

- ▶ Carry out action steps according to the illustration.
- ▷ Set temperature alarm values are displayed.

6.1.21 Door alarm



Use this function to activate or deactivate the door alarm. The door alarm sounds if the door is open for too long. The door alarm is activated on delivery. You can set how long the door may be open before the door alarm sounds.

The following values can be set:

- 15 seconds
- 30 seconds
- 60 seconds
- 90 seconds
- 120 seconds
- 150 seconds
- 180 seconds
- Off

Setting the door alarm



Fig. 139

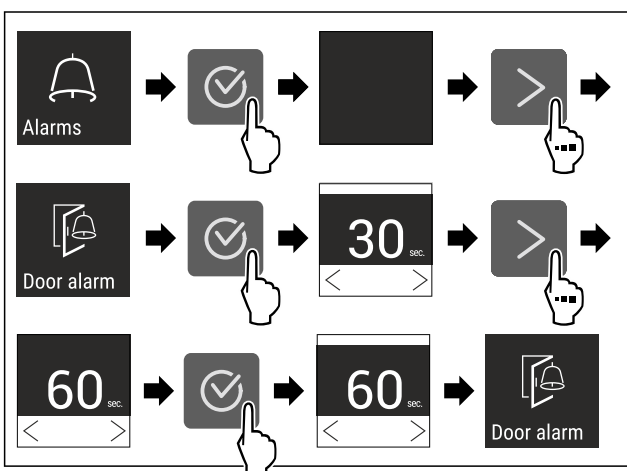

Fig. 141 Example illustration: Switch door alarm from 30 seconds to 60 seconds.

- ▶ Carry out action steps according to the illustration.
- ▷ The door alarm is set.

Deactivating the door alarm



Fig. 142

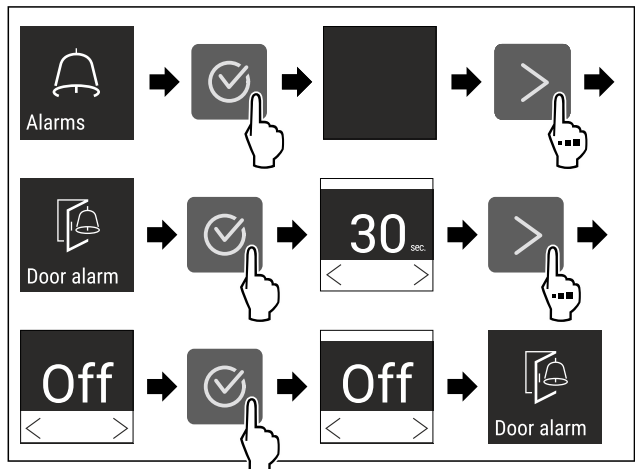

Fig. 143

- ▶ Carry out action steps according to the illustration.
- ▷ The door alarm is deactivated.

6.1.22 Alarm simulation



This setting makes it possible to simulate a change in the appliance temperature to check the function of any safety devices that may be connected.

Starting alarm simulation



Fig. 144

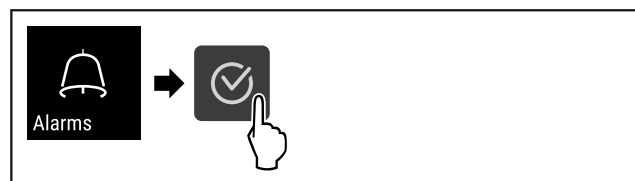

Fig. 145

- ▶ Carry out action steps according to the illustration.

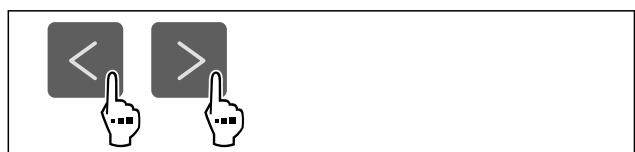

Fig. 146

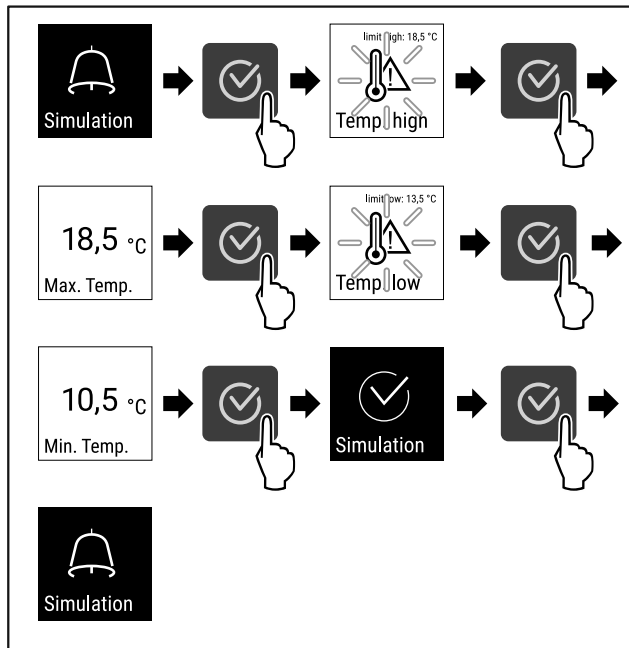

Fig. 147

- ▶ Carry out action steps according to the illustration.
- ▷ The simulation has been performed.
- ▷ Connected safety devices should have triggered.



6.1.23 Alarm relay

This setting makes it possible to relay one or more alarms to an external alarm receiver connected to the appliance.

The following settings can be selected:

- Alarm type:
 - Door alarm
 - Temperature alarm
 - Door alarm and temperature alarm
 - All
- Confirm:
 - **Yes:** The alarm is terminated at the appliance and the externally connected receiver.
 - **No:** The alarm is acknowledged at the appliance and remains active at the receiver until the error is rectified.
- Update (only visible if “Yes” is selected when confirming):
 - **Yes:** Alarm repeats.
 - Temperature alarm** depending on the set time (see 6.1.20 Temperature alarm) (If the alarm delay time is set to “0”, the alarm relay will not repeat the alarm.)
 - Door alarm** after 1 or 4 minutes * (see 6.1.21 Door alarm)
 - **No:** Alarm is continuously acknowledged.

Activating alarm relay

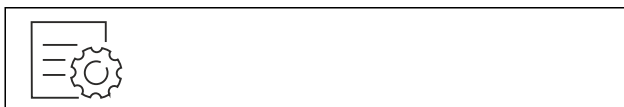

Fig. 148

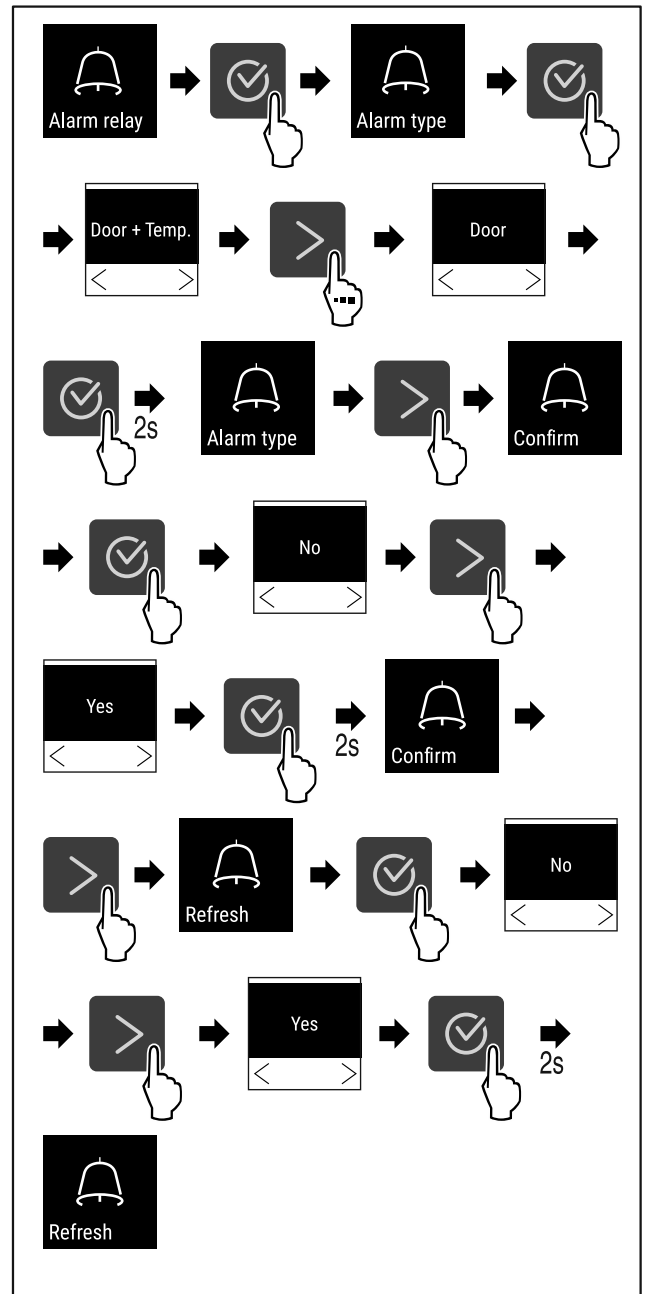

Fig. 149

- ▶ Carry out action steps according to the illustration.
- ▷ The alarm relay has been set.



6.1.24 Demo mode

Demo mode is a special feature for dealers who want to demonstrate appliance features. If you activate demo mode, all refrigeration functions are deactivated.

If you switch on your appliance and a “D” appears on the status display, demo mode is already activated.

If you activate and then deactivate demo mode, the appliance will be reset to factory defaults. (see 6.1.25 Resetting to factory settings)

Activating demo mode



Fig. 150

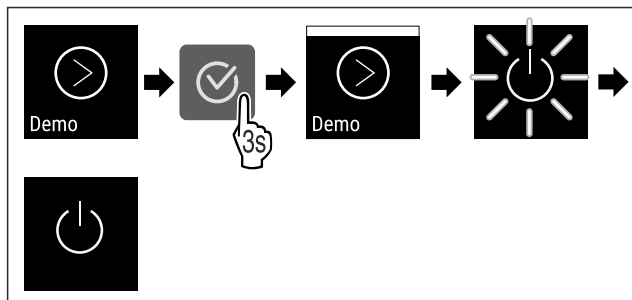

Fig. 151

- ▶ Carry out action steps according to the illustration.
- ▷ Demo mode is activated.
- ▷ Appliance is switched off.
- ▶ Switch on the appliance. (see 4.16 Switching on appliance (first use))
- ▷ "D" appears in the status display.

Deactivating demo mode



Fig. 152

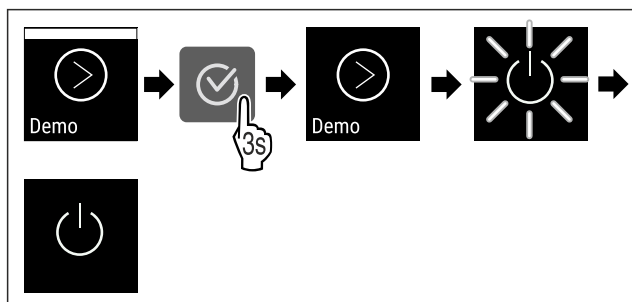

Fig. 153

- ▶ Carry out action steps according to the illustration.
- ▷ Demo mode is deactivated.
- ▷ Appliance is switched off.
- ▶ Switch on the appliance. (see 4.16 Switching on appliance (first use))

▷ Appliance is reset to factory settings.

6.1.25 Resetting to factory settings



Use this function to reset all settings to factory defaults. All settings you have made so far are reset to their original settings.

Performing a reset



Fig. 154

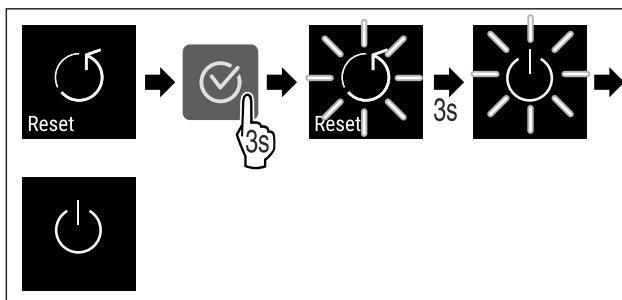



Fig. 155

- ▶ Carry out action steps according to the illustration.
- ▷ Device is reset.
- ▷ Device is switched off.
- ▶ Restart the device. (see 4.16 Switching on appliance (first use))







6.2 Messages







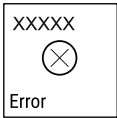





6.2.1 Warnings

Warnings are issued by means of an audio signal and visually via a symbol on the display. The signal gets louder until the warning is acknowledged.

Message	Cause	Remedy
 <p>Door open</p>	<p>This message appears if the door is open for too long.</p>	<ul style="list-style-type: none"> ▶ Close door.  <ul style="list-style-type: none"> ▶ Press confirmation button. ▶ Alarm is stopped. <p>Note You can set how long it takes for this message to appear (see 6.1.21 Door alarm).</p>

Controls





Message	Cause	Remedy
 <p>Temperature</p> <p>Temperature alarm</p>	<p>This message appears if the temperature does not match the set temperature. Reasons for the differences in temperature can be:</p> <ul style="list-style-type: none"> - Warm items for refrigeration have been placed inside. - Too much warm room air flowed in when rearranging and removing refrigerated products. <p>The power was cut off for a prolonged period.</p>	 <ul style="list-style-type: none"> ▶ Press confirmation button. ▶ The highest temperature is shown.  <ul style="list-style-type: none"> ▶ Press confirmation button. ▶ The current temperature flashes and display switches to the temperature alarm symbol until the set temperature is reached. ▶ Check quality of refrigerated items.
 <p>Error</p> <p>Error</p>	<p>The appliance is faulty, there is an appliance error or a component of the appliance has a fault.</p>	<ul style="list-style-type: none"> ▶ Store the refrigerated items elsewhere.  <ul style="list-style-type: none"> ▶ Press confirmation button. <p>▶ Error code is displayed.</p>   <ul style="list-style-type: none"> ▶ Press confirmation button. ▶ A further error code is displayed if there is one. <p>Or</p> <ul style="list-style-type: none"> ▶ Status screen is displayed with flashing  <p>arrow symbol</p> <ul style="list-style-type: none"> ▶ Pressing the navigation buttons displays error code(s) again. ▶ Make a note of error code(s) and contact Customer Service.

 <p>Power</p> <p>Power cut</p>	<p>The message appears after an interruption to the power supply if the temperature is above the alarm limit when the power returns.</p>	 <ul style="list-style-type: none"> ▶ Press confirmation button. <p>Highest temperature and number of electricity supply interruptions are displayed.</p>  <ul style="list-style-type: none"> ▶ Press confirmation button. ▶ Alarm is stopped and current temperature is displayed. ▶ Check quality of refrigerated items.
 <p>Defrost error</p> <p>Defrost error</p>	<p>The automatic defrosting is not working properly. The previous 5 defrost cycles were not successful.</p>	 <ul style="list-style-type: none"> ▶ Press confirmation button. ▶ Alarm is stopped. ▶ Contact Customer Service (see 9.3 Customer Service) .
 <p>WiFi error</p> <p>WiFi error</p>	<p>WiFi connection is interrupted.</p>	<ul style="list-style-type: none"> ▶ Check connection.  <ul style="list-style-type: none"> ▶ Press confirmation button. ▶ Alarm is stopped.
 <p>WWW error</p> <p>WWW error, WiFi</p>	<p>This message appears if there is no internet connection via WiFi.</p>	<ul style="list-style-type: none"> ▶ Check connection.  <ul style="list-style-type: none"> ▶ Press confirmation button. ▶ Alarm is stopped.
 <p>LAN error</p> <p>LAN error</p>	<p>LAN connection is interrupted.</p>	<ul style="list-style-type: none"> ▶ Check connection and network cable.  <ul style="list-style-type: none"> ▶ Press confirmation button. ▶ Alarm is stopped.
 <p>WWW error</p> <p>WWW error, LAN</p>	<p>This message appears if there is no internet connection via LAN.</p>	<ul style="list-style-type: none"> ▶ Check connection.  <ul style="list-style-type: none"> ▶ Press confirmation button. ▶ Alarm is stopped.

Features

6.2.2 Reminder

Reminders appear when you are being asked to do something. They are issued by means of an audio signal and visually via a symbol on the display. Acknowledge the message by pressing the confirmation button.

Message	Cause	Remedy
 <p>Maintenance</p> <p>Maintenance reminder</p>	<p>The message appears when the timer for the set maintenance interval has expired.</p>	 <ul style="list-style-type: none"> ▶ Press confirmation button. ▶ Alarm is stopped. <p>Note</p> <p>The maintenance interval can be set (see 6.1.7 Maintenance interval reminder).</p>
 <p>Recording</p> <p>Recording reminder</p>	<p>This message appears when the temperature recording memory (999 hours) is full.</p>	 <ul style="list-style-type: none"> ▶ Press confirmation button ▶ Alarm is stopped. ▶ The oldest data are overwritten. <p>Note</p> <p>The temperature recording can be reset (see 6.1.4 Temperature recording).</p>

7 Features

7.1 Safety lock

The lock in the appliance door is equipped with a safety mechanism.

7.1.1 Locking appliance

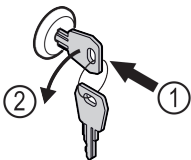

Fig. 156

- ▶ Insert key.
- ▶ Turn key anticlockwise by 90°.
- ▷ The appliance is locked.

7.1.2 Unlocking appliance

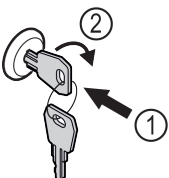

Fig. 157

- ▶ Insert key Fig. 157 (1).
- ▶ Turn key clockwise by 90° Fig. 157 (2).
- ▷ The appliance is unlocked.

7.2 Sensors

The appliance can be equipped with the following sensors for temperature monitoring:

- Safety thermostat sensor
- C sensor

7.2.1 Safety thermostat sensor

The safety thermostat sensor monitors the temperature drop and thus protects against excessively low temperatures (Freeze Protect). If the temperature drops below the threshold value, the appliance regulates the temperature automatically. The error message FRZ. PROT (Freeze Protect) (see 6.2 Messages) appears.

Note

Do not cover the safety thermostat sensor.

7.2.2 C sensor (control sensor)

The C sensor is permanently installed and regulates the interior temperature of the appliance. You can calibrate the C sensor if necessary. (see 6.1.19 Sensor calibration)

7.3 Interfaces

There are various connection options on the back of the appliance.

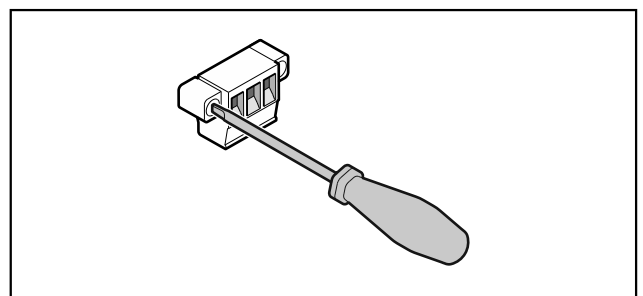

Fig. 158

Note

Screws secure the plugs. To enable disconnection of the plugs, loosen the screws on the left and right.

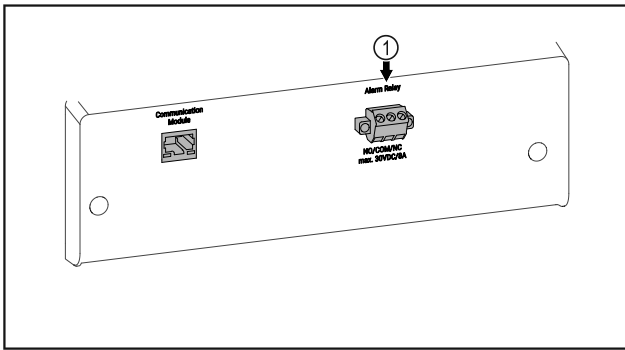

Fig. 159

(1) Potential-free alarm output

(2) COM (common)
External voltage source

8 Maintenance

8.1 Maintenance schedule

Maintenance work is to be performed at regular intervals to ensure proper appliance function.



CAUTION

Danger of injury and damage due to unprofessional maintenance work!

Personal injury and material damage.

► Maintenance work may only be performed by trained specialist personnel.



WARNING

Short-circuit hazard due to live parts!

Electric shock or damage to the electronics.

► **Switch off the appliance.**

► Pull out mains plug or switch off fuse.

7.3.1 Potential-free alarm output



WARNING

Risk of injury due to electric shock!

► The appliance may only be connected to an external alarm device by trained specialist personnel.

These three contacts can be used to connect a visual or an acoustic alarm device. The connection is designed for a maximum of **30 V (DC) - 8 A** from a safety low voltage source SELV (**minimum current 150 mA**).

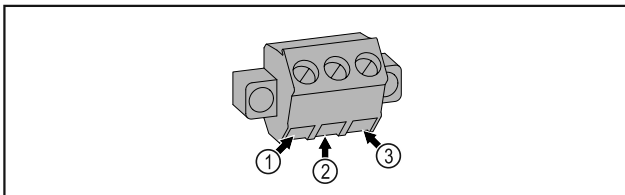

Fig. 160

(1) NO (normally open)
Connection for indicator lamp, which is active in normal operation or when the appliance is switched off.

(3) NC (normally closed)
Connection for alarm lamp or audible alarms, which is active when an alarm is triggered or there is a lack of power supply.

Note

A maintenance reminder function can be activated. (see 6.1.7 Maintenance interval reminder)

Note

We recommend creating a maintenance log in which all work (repairs, checks) performed is documented.

Note

Liebherr recommends yearly maintenance. For an individual offer, please contact Customer Service (see 9.3 Customer Service).

Component	Activity	Maintenance interval
Sheet metal parts	Check for damage and corrosion. Replace damaged parts: (see 9.3 Customer Service)	Yearly
Door, hinges	Check alignment (see 4.14 Aligning the door) , ease of movement, and tight fit.	Yearly
Lock, door handle *	Check for ease of movement and tight fit.	Yearly
Door seal	Check for damage, wear, and tight fit. A replacement door seal is available via Customer Service (see 9.3 Customer Service) .	Yearly
Sensor	Calibrate sensor. (see 6.1.19 Sensor calibration)	Yearly
Sensor feedthrough	Check that the sealing compound is intact.	Yearly
Surfaces	Cleaning (see 8.3 Cleaning the appliance)	Recommendation: monthly or as required/specified at installation location

Maintenance

Component	Activity	Maintenance interval
Surfaces	Disinfection	Recommendation: monthly or as required/specified at installation location
Installation location, appliance	Decontamination The appliance is suitable for room decontamination with hydrogen peroxide H ₂ O ₂ . In this context, the values of the following application specifications must not be exceeded: Concentration: maximum 250 ppm. Humidity: maximum 85%. Maximum permissible room temperature as per climate class. (see 1.4 Range of use of appliance)	Recommendation: as required/specified at installation location, maximum 2x per year
Fan air slots	Cleaning (see 8.3.3 Cleaning fan cover)	Yearly
Alarm relay		
Mains cable	Check for damage.	Yearly or if there is a change of location
Tilt angle	Check for proper function and tight fit.	Yearly or if there is a change of location
Adjusting feet/castors	Check for proper function, damage, and tight fit. Replace damaged parts. (see 9.3 Customer Service)	Yearly
Defrost water collection tray	Check the fill level of the defrost water collection tray and empty if necessary.	Regular visual inspection

8.2 Defrosting appliance



WARNING

Improper defrosting of the appliance!
Injuries and damage.

- ▶ Do not use mechanical equipment or other methods to speed up the defrosting process other than those recommended by the manufacturer.
- ▶ Do not use electrical heating or steam-cleaning appliances, naked flames or defroster sprays to defrost.
- ▶ Do not use sharp objects to remove ice.

Defrosting is performed automatically. Defrost water drops into defrost water collection tray and must be emptied at regular intervals.

Note

To avoid having to empty the defrost water collection tray frequently, you can place a container under the drain opening in the tray.

The defrost water collection tray may only be inserted on the lowest support rib.

To maintain the functionality of the appliance, we recommend defrosting it when there is a high buildup of ice. Icing in the interior is determined by the location (e.g. high humidity), settings on the appliance and incorrect user behaviour.

Manual defrosting:

- ▶ Switch off appliance. (see 6.1.2 Switching appliance on and off)
- ▶ Pull out mains plug.
- ▶ Store refrigerated items elsewhere.
- ▶ Leave appliance door open during defrosting process.
- ▶ Pull out defrost water collection tray at the front, empty and clean the appliance.

8.3 Cleaning the appliance

8.3.1 Preparing



WARNING

Short-circuit hazard due to live parts!
Electric shock or damage to the electronics.

- ▶ **Switch off the appliance.**
- ▶ Pull out mains plug or switch off fuse.



WARNING

Risk of fire

- ▶ Do not damage the refrigeration circuit.

- ▶ Empty the appliance.
- ▶ Pull out the mains plug.
- ▶ Observe the notes on transporting the appliance. (see 4.3 Transporting appliance)

8.3.2 Cleaning housing

NOTICE

Improper cleaning!
Damage to the appliance.

- ▶ Only use soft cleaning cloths and ph-neutral all-purpose cleaners.
- ▶ Do not use abrasive sponges or steel wool which may cause scratches.
- ▶ Do not use any sharp or abrasive cleaning agents, nor any that contain sand, chloride or acid.

WARNING

Risk of injury and damage as a result of hot steam!
Hot steam can lead to burns and can damage the surfaces.

- ▶ Do not use any steam cleaners!

NOTICE

Risk of damage due to short circuit.

- ▶ When cleaning the appliance, make sure no water gets into the electrical components.

- ▶ Wipe the housing down with soft, clean cloth. If very dirty, use lukewarm water with a neutral cleaner. Glass surfaces can also be cleaned with glass cleaner.
- ▶ Clean condenser coil each year. If the condenser coil is not cleaned, this significantly reduces the efficiency of the appliance.

8.3.3 Cleaning fan cover

NOTICE

Risk of damage due to short circuit.

- ▶ When cleaning the appliance, make sure no water gets into the electrical components.

NOTICE

Improper cleaning!

Damage to the appliance.

- ▶ Only use soft cleaning cloths and ph-neutral all-purpose cleaners.
- ▶ Do not use abrasive sponges or steel wool which may cause scratches.
- ▶ Do not use any sharp or abrasive cleaning agents, nor any that contain sand, chloride or acid.

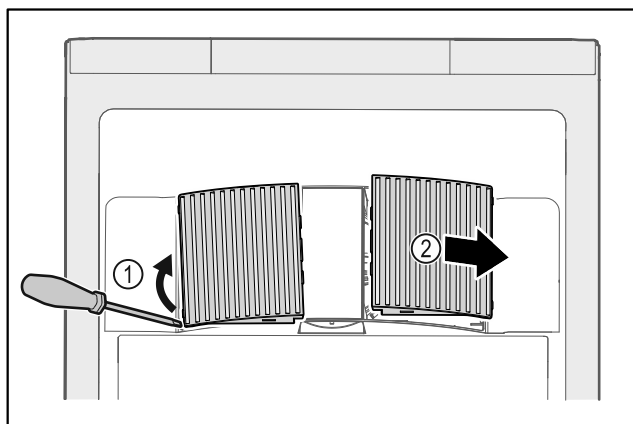

Fig. 161

- ▶ Carefully lever out fan covers from the side Fig. 161 (1) and remove towards the front Fig. 161 (2).
- ▶ Rinse the air slots of the fan covers under running water. If very dirty, use lukewarm water with a neutral cleaner.
- ▶ Leave fan covers to air-dry completely.
- ▶ Reattach fan covers to the appliance.

8.3.4 Cleaning interior

WARNING

Short-circuit hazard due to live parts!

Electric shock or damage to the electronics.

- ▶ **Switch off the appliance.**
- ▶ Pull out mains plug or switch off fuse.

WARNING

Risk of injury and damage as a result of hot steam!
Hot steam can lead to burns and can damage the surfaces.

- ▶ Do not use any steam cleaners!

NOTICE

Improper cleaning!

Damage to the appliance.

- ▶ Only use soft cleaning cloths and ph-neutral all-purpose cleaners.
- ▶ Do not use abrasive sponges or steel wool which may cause scratches.
- ▶ Do not use any sharp or abrasive cleaning agents, nor any that contain sand, chloride or acid.

Note

- ▶ Defrost water drain (see 1.2 Overview of appliance and equipment) : Remove deposits using a thin material (for example a cotton bud).

Note

Do not damage or remove the type plate on the inside of the appliance. The type plate is important for Customer Service. (see 9.3 Customer Service)

- ▶ Open the door.
- ▶ Empty the appliance.
- ▶ Clean interior and equipment parts with lukewarm water and a little detergent. Do not use any gritty or acidic cleaning agent or any chemical solvent.

8.3.5 After cleaning

- ▶ Wipe appliance and equipment parts dry.
- ▶ Connect and switch on appliance. Once the temperature is sufficiently cold:
- ▶ put in items for refrigeration goods.
- ▶ Repeat cleaning regularly.
- ▶ Clean and dust refrigerators with a heat exchanger (metal grille on the rear of the appliance) once per year.

9 Customer help

9.1 Technical specifications

Temperature range	
Cooling	+3 °C to +16 °C

Maximum load per shelf ^{A)}		
Appliance width	600 mm	750 mm
Grid shelves	45 kg	60 kg
Glass shelf	40 kg	40 kg
Wooden shelf	45 kg	60 kg
Drawer	50 kg	50 kg

A) Heavier loads may result in a slight bending of the shelves.

Maximum total load and net weight			
Model (see 4.2 Appliance dimensions)	Maximum load	total	Net weight
SRF.. 3501	180 kg		60 kg
SRFfg 4001	225 kg		70 kg

Customer help

Maximum total load and net weight		
Model (see 4.2 Appliance dimensions)	Maximum total load	Net weight
SRF.. 5501	300 kg	80 kg

Maximum net capacity
See net capacity on the type plate. (see 1.2 Overview of appliance and equipment)

Set-up conditions	
Degrees of pollution (surrounding the appliance)	PD2
Ambient temperature	+10 °C to +35 °C
Maximum relative ambient moisture	75%, not condensing
Maximum operating elevation (metres above sea level)	2000 m 1500 m (glass door)

Electrical values	
Nominal voltage	See type plate. (see 1.2 Overview of appliance and equipment)
Frequency	
Connected load	

Electrical values		
Maximum fluctuations	mains	+/-10 %
Overvoltage category	cate-	II

9.2 Technical fault

Your appliance is designed and built to ensure it works reliably and has a long service life. In the unlikely event that a fault occurs during operation, please check whether the fault is due to an operating error. If this is the case, you will be charged for the cost incurred even if this falls within the warranty period.

You can fix the following faults yourself.

9.2.1 Appliance function

Defect	Cause	Remedy
The appliance is not working.	→ The appliance is not switched on.	▶ Switch on the appliance.
	→ The mains plug is not properly plugged into the socket.	▶ Check the mains plug.
	→ There is something wrong with the fuse in the socket.	▶ Check fuse.
	→ Power cut	▶ Keep the appliance closed. ▶ If necessary move the refrigerated/frozen items to another fridge or freezer if the power is off for a prolonged period.
	→ The appliance plug is not properly inserted in the appliance.	▶ Check appliance plug.
Temperature is not cold enough.	→ The appliance door is not closed properly.	▶ Close appliance door.
	→ Ventilation is not sufficient.	▶ Clear ventilation grille and clean it.
	→ The ambient temperature is too high.	▶ Ensure the correct ambient conditions: (see 1.4 Range of use of appliance)
	→ The appliance was opened too many times or for too long.	▶ Wait to see if the appliance goes back to the required temperature by itself. If not, contact Customer Service. (see 9.3 Customer Service)
	→ The temperature is set incorrectly.	▶ Set a colder temperature and check after 24 hours.
	→ The appliance is too close to a heat source (oven, radiator, etc).	▶ Change where the appliance or the heat source are located.

9.3 Customer Service

First check whether you can remedy the fault yourself . If this is not the case, please contact Customer Service.

You can find the address in the enclosed brochure "Liebherr-Service" or at home.liebherr.com/service.



WARNING

Unprofessional repair!
Injuries.

- ▶ Have any repairs and action - not expressly specified - on the appliance and mains cable carried out by service personnel only. (see 8 Maintenance)
- ▶ A damaged mains cable may only be replaced by the manufacturer, the manufacturer's Customer Service or a similarly qualified person.
- ▶ In the case of appliances with an IEC connector, the change may be made by the customer.

9.3.1 Contacting Customer Service

Make sure you have the following appliance data at the ready:

- Appliance name (model and index)
- Service no. (Service)
- Serial no. (S no.)
- ▶ Access the appliance information via the display (see 6.1.15 Device information).
- or-
- ▶ Refer to the type plate for appliance information. (see 9.4 Type plate)
- ▶ Note down appliance information.
- ▶ Inform Customer Service: Report faults and the appliance information.
- ▷ This will help us to provide a fast and focussed service.
- ▶ Follow any further instructions provided by Customer Service.

9.4 Type plate

The type plate is inside the appliance. See appliance overview.

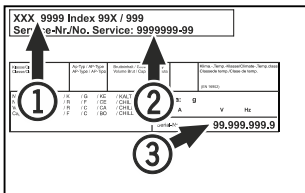

Fig. 162

- (1) Appliance designation (3) Serial No.
(2) Service No.

10 Shutting down

- ▶ Empty the appliance.
- ▶ Switch off the appliance.
- ▶ Pull out the mains plug.
- ▶ Remove appliance connector if required: remove and at the same time move from left to right.
- ▶ Clean appliance (see 8.3 Cleaning the appliance) .
- ▶ Leave the door open so that no bad odours form.

Note

Damage to the appliance and malfunctions!

- ▶ After shutting down, only store the appliance at the permitted room temperature of between -10 °C and +50 °C.

11 Disposal

11.1 Preparing appliance for disposal



Liebherr uses batteries in some of its appliances. In the EU, for environmental reasons, legislation obliges the end user to remove these batteries before disposing of old appliances. If your appliance contains batteries, a corresponding notice is attached.

Lamps If you can remove the lamps yourself without destroying them, also remove these before disposal.

- ▶ Take the appliance out of operation.
- ▶ Appliances with batteries: remove the batteries. For description, see **Maintenance** chapter.
- ▶ If possible: remove lamps without destroying them.

11.2 Disposing of the appliance in an environmentally friendly manner



The appliance still contains valuable materials and must be disposed of separately from unsorted municipal waste.



Dispose of batteries separately from the old appliance. To do this, you can return the batteries free of charge to retailers as well as recycling centres and collection centres for recyclable materials.

Lamps

Dispose of removed lamps via the respective collection systems.

For Germany:

You can dispose of the appliance free of charge via the class 1 collection containers at the local recycling and recyclable material collection centres. When purchasing a new fridge/freezer, if the sales area > 400 m², retailers will also take back the old appliance free of charge.



WARNING

Leaking coolant and oil!

Fire. The coolant contained in the appliance is eco-friendly, but also flammable. The oil contained in the appliance is flammable. Escaping coolant and oil can ignite if the concentration is high enough and in contact with an external heat source.

- ▶ Do not damage the pipelines of the coolant circuit and the compressor.
- ▶ Observe the notes on transporting the appliance. (see 4.3 Transporting appliance)
- ▶ Transport the appliance without damaging it.
- ▶ Dispose of batteries, lamps and the appliance according to the above specifications.

Additional information

12 Additional information

Further information on warranty conditions can be found in the enclosed service brochure or on the Internet at <https://home.liebherr.com>.

If appliance malfunctions, inform: _____

Model ID / Inventory number: _____

Quick Start Guide for everyday use

Information about using this Quick Start Guide:

- This Quick Start Guide is not a substitute for the full operating instructions nor is it a substitute for appliance training.
- This Quick Start Guide provides support for everyday use and handling the appliance.
- Read the full operating instructions and the safety notes contained therein.

This quick start guide is for: SRFfg 35../40../55..



Scanning the QR code will open the full operating instructions:



Intended use

This laboratory refrigerator, with an interior free of ignition sources, is suitable for professional storage of highly flammable products in closed containers, at temperatures between 3 °C and 16 °C.

Foreseeable incorrect use

Do not use the appliance for the following applications:

- Storage and refrigeration of:
 - Chemically unstable substances
 - Blood, plasma or other body fluids for the purpose of infusion, application or introduction in the human body
- Use in potentially explosive atmospheres
- Use outdoors or in areas exposed to dampness and splashing water

When stocking, observe the following points:

- Position grid shelves according to the height required.
- Observe maximum load.
- When the storage temperature has been reached, load the appliance (compliance with cold chain).
- Keep the ventilation slots of the recirculation fan free in the interior.
- Produce for cooling must not come into contact with the evaporator on the rear wall.
- Keep liquids in closed containers.
- Leave space when storing refrigerated goods to ensure good air circulation.

Status display

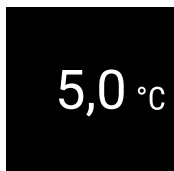

Fig. 163 Status display with actual temperature

Displaying temperature recording

The temperature recording displays the length of the recording and the minimum and maximum temperatures measured during this period of time.

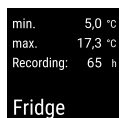

Fig. 164

Resetting temperature recording

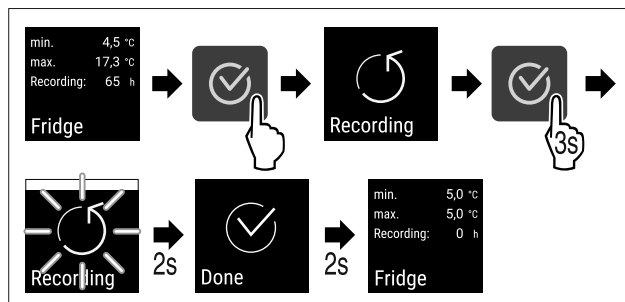

Fig. 165

Unlocking appliance

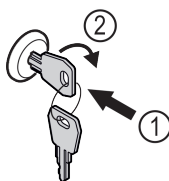

Fig. 166

- ▶ Insert the key. Fig. 166 (1)
- ▶ Turn the key clockwise by 90°. Fig. 166 (2)
- ▷ The appliance is unlocked.

Locking appliance

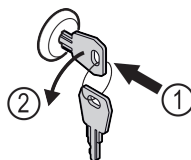

Fig. 167

- ▶ Insert the key. Fig. 167 (1)
- ▶ Turn the key anticlockwise by 90°. Fig. 167 (2)
- ▷ The appliance is locked.

Cleaning appliance

- ▶ Empty the appliance.
- ▶ Pull out the mains plug.
- ▶ Observe the information in the operating instructions.
- ▶ Dry the appliance and equipment thoroughly after cleaning.
- ▶ Connect the appliance.
- ▶ Switch on the appliance.
- ▶ Load the appliance once the storage temperature is reached.



What should I do if there is a fault?

A message appears in the display if there is a fault. Messages have different meanings:

Symbol colour in the display	Meaning	Remedy
WHITE with black bar	Reminder Reminder of general procedures. You can carry out these procedures to eliminate the message.	Consult the operating instructions and perform the troubleshooting steps.
WHITE	Warning Appears when there are malfunctions. You can eliminate simple malfunctions yourself.	Consult the operating instructions and perform the troubleshooting steps.

If you cannot remedy the fault yourself, contact a competent member of staff or your nearest customer service outlet.

Cut out the page





home.liebherr.com/fridge-manuals

EN Refrigerator
ORIGINAL OPERATOR'S MANUAL

Issue date: 20240326

Part number index: **7080680-0**
0

Liebherr Hausgeräte Lienz GmbH
Dr.-Hans-Liebherr-Strasse 1
A-9900 Lienz
Österreich

