

Translation of the original

Installation manual for the CO₂ Emergency Cooling

Ultra-Low Temperature Freezer SUFsg

	Model	Gross content in liters	Voltage
	SUFsg 5001,001	491	230 V
	SUFsg 7001,001	728	230 V
	SUFsg 5001,123	491	208-240 V
	SUFsg 7001,123	728	208-240 V
UL chambers	SUFsg 5001,137	491	120 V
	SUFsg 7001,137	728	120 V
Chambers with water cooling	SUFsg 5001,H72	491	230 V
	SUFsg 7001,H72	728	230 V

SUFsg 5001
SUFsg 7001

7085 886-01

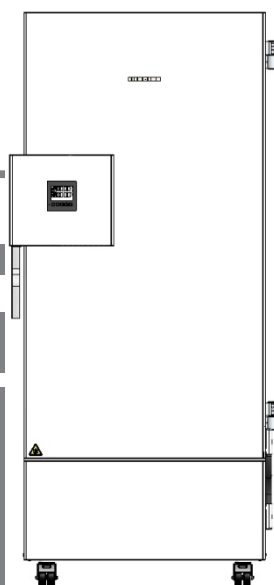

LIEBHERR

Table of content

1.	Preface	3
1.1	General guidelines	3
1.2	Syntax	3
1.3	Safety instructions structure	4
1.3.1	Safety instructions structure	4
1.3.2	Warning levels	4
1.3.3	Safety alert symbol	4
1.3.4	Warning signs	5
1.3.5	Mandatory action signs	5
1.3.6	Information symbol	5
2.	Safety instructions	6
2.1	Qualification of service personnel	6
2.2	Safety and hazard instructions	7
3.	CO₂ emergency cooling	8
3.1	Required tools, components, and accessories	8
3.2	Overview	9
3.3	Installation	11
3.3.1	Mechanical installation	11
3.3.2	Electrical connection	19
3.4	Leak detection	23
3.5	Function test	24

1. Preface

1.1 General guidelines

This installation manual describes the installation of the CO₂ emergency cooling of the SUFsg ultra-low temperature freezer and is aimed at service personnel who should install these units.

The repair of the cooling system must only be performed by personnel having specialized training and special tools must be available.

References about the required qualification of the personnel can be found in chap. 2.1.

Before starting the service work at an SUFsg ultra-low temperature freezer, compare order and serial number of the unit with the validity note on the front page of this manual.

The of electrical equipment marking of the components refers to the circuit diagrams. With other sizes of the device the marking can deviate. Therefore, use always the appropriated circuit diagram of the device.

Additional options are indicated in the text.

This manual will be updated if necessary. Always use the latest version of the manual.

All information about initial operation, normal operation, cleaning, alarm and error messages can be found in the relevant operating manual delivered with the SUFsg ultra-low temperature freezer.



Before connecting the unit, compare the data given on the type plate with the values of your power supply network.

1.2 Syntax

Syntax	Meaning
(-1A1)	Marking of electrical equipment or components of the cooling system, and of electric contacts (Equipment code)
<Taste>	Button to be pushed
"Text"	Displayed text or text to be entered

1.3 Safety instructions structure

This installation manual employs the terms and symbols below to describe dangerous situations, in line with the harmonization of ISO 3864-2 and ANSI Z535.6.

1.3.1 Safety instructions structure

- Instruction how to avoid the hazard: mandatory action
- ⊘ Instruction how to avoid the hazard: prohibition

1.3.2 Warning levels

Depending on the probability of serious consequences, potential dangers are identified with a signal word, the corresponding safety color, and if appropriate, the safety alert symbol.



DANGER

Indicates an imminently hazardous situation that, if not avoided, will result in death or serious (irreversible) injury.



WARNING

Indicates a potentially hazardous situation which, if not avoided, could result in death or serious (irreversible) injury.



CAUTION

Indicates a potentially hazardous situation which, if not avoided, may result in moderate or minor (reversible) injury.

NOTICE







Indicates a potentially hazardous situation which, if not avoided, may result in damage to the product and/or its functions or of a property in its proximity.

1.3.3 Safety alert symbol





Risk of injury. Observe all measures that are marked with the safety alert symbol in order to avoid death or injury.

1.3.4 Warning signs

	Danger of electric shock
	Danger of cutting injuries
	Danger of injuries by jumping off mechanical components
	Danger of suffocation by CO ₂
	Danger of suffocation by oxygen deficiency
	Danger by gas cylinders

1.3.5 Mandatory action signs





	Pull out the power plug
	Wear protective goggles
	Wear protective gloves

1.3.6 Information symbol

	Important information
-------------------------------------------------------------------------------------	-----------------------

2. Safety instructions

2.1 Qualification of service personnel

	 WARNING
	<p>Danger of malfunctions due to incorrect maintenance or repair. Injuries, damage to the chamber and samples</p> <ul style="list-style-type: none"> ➤ General maintenance work must be conducted by licensed electricians or experts authorized by the manufacturer. ➤ Maintenance work at the refrigeration system must only be conducted by qualified personnel who underwent training in accordance with EN 13313:2010 (e.g. a refrigeration technician with certified expert knowledge acc. to regulation 303/2008/EC). Follow the national statutory regulations.
	NOTICE
	<p>Risk of faulty cooling operation after improper calibration and adjustment. Damage of samples, incorrect test results.</p> <ul style="list-style-type: none"> ➤ Carry out the calibration and, if necessary, the adjustment regularly and carefully.
	<p>The Ultra-low temperature freezer should only be maintained, repaired and calibrated / adjusted by qualified personnel.</p>



To be able to carry out the work on ultra-low temperature freezer the enforcing personnel must be familiar with operation, maintenance, repair, calibration, and adjustment of the device. Sufficient qualification is achieved by:



- Electro technical training
- Knowledge of the present installation manual
- Knowledge of the current operating manual
- Experience in servicing ultra-low temperature freezers

Maintenance, repair and inspection of the cooling system must be performed by trained personnel, that has a certification in accordance with EC Regulation 303/2008 and expert knowledge in accordance with EN 13313:2010.

All work on the cooling system (repairs, inspections) must be recorded in the associated plant log book.

2.2 Safety and hazard instructions

 	 DANGER
	<p>Electrical hazard during live maintenance and repair work Deadly electric shock.</p> <ul style="list-style-type: none"> ➤ Before conducting most of the described work, turn off the chamber at the main power switch and disconnect the power plug ➤ Take all precautionary measures that a unit which is disconnected from the power supply will not be inadvertently connected to the power supply. ➤ If the unit must be live to perform special service tasks: Make sure that a second person is present who is able to switch off the unit in case of emergency.

 	 CAUTION
	<p>Danger of cutting by sharp edges of sheet metal parts. Cutting injuries.</p> <ul style="list-style-type: none"> ➤ Wear protective gloves during mounting and dismantling inner chamber and housing because sheet metal components may be sharp-edged.

	NOTICE
	<p>Danger of damaging electronic components by handling malpractices and electrostatic discharge. Malfunctions and damage of the electronics.</p> <ul style="list-style-type: none"> ➤ Prior to work at electronic components, take appropriate protective measures against electrostatic discharge. Wearing ESD shoes and a grounding bracelet have shown to be useful. ➤ Before opening the lock and controller housing, electrostatically discharge by touching a grounded metallic object. ➤ Prior to work at the electrical equipment check identity of the components with the aid of the wiring diagram. The assembly of the electrical equipment may be different from the description in this manual. <p>⊙ NEVER let mechanical components hang at electric cables. Electric cables are not appropriate to hold bigger components and will be damaged if you do so</p>

3. CO₂ emergency cooling

3.1 Required tools, components, and accessories







The following tables show the tools, components, and accessories that are required for the installation.

Required tools	<ul style="list-style-type: none"> • Torx® screwdriver size 20 • Slotted screwdriver • Open end wrench 14 mm • Open end wrench 16 mm • Open end wrench 30 mm (connection of the CO₂ pressure cylinder) • Allen wrench 4 mm • Cutter • Universal pliers
Auxiliary materials	<ul style="list-style-type: none"> • Leak detection spray • SUFG Service manual • Circuit diagram of the unit • Operating manual of the Ultra-low temperature freezer
Mechanical components	<ul style="list-style-type: none"> • CO₂ emergency cooling for SUFG (Retrofit kit) <div style="display: flex; align-items: center; margin-top: 10px;">  <p>To perform a function test following installation (chap. 3.5), a CO₂ pressure cylinder <u>with dip tube</u> must be provided by the customer.</p> </div>

3.2 Overview

The CO₂ emergency cooling kit contains the following parts:

Description	Quantity / Unit
Mounting material, mechanical	
Sealant Terostat-IX	0.05 kg
Armaflex insulating tape 50 x 3	0.7 m
Armaflex insulating tube D10 x 11 mm	0.7m
Armaflex insulating tube D06 x 6 mm	0.3 m
Armaflex insulating tube D22 x 12 mm	0.2 m
EJOT thin sheet metal screw 40x9.5 T20 zinc-coated	6 pc.
Silicon hose, transparent Ø 20	0.1 m
Silicon hose, transparent Ø 16	0.1 m
Vent pipe Ø16 x 1,0 x 270 mm, curved	1 pc.
CO ₂ injection pipe, curved, 6 mm, with union nut and cutting ring	1 pc.
CO ₂ injection pipe, curved, with angled screw connection, pre-insulated	1 pc.
Housing for CO ₂ emergency cooling, pre-assembled	1 pc.
Danger warning label	1 pc.
Installation manual for CO ₂ emergency cooling	1 pc.
Cable tie 200 mm with base, black	2 pc.
Mounting material, electrical	
Panel connector with flange, pre-assembled	1 pc.
Cable tie 140mm, white	10 pc.

 <p>CO₂ injection pipe, curved, 6 mm, with union nut and cutting ring</p>	 <p>6 x EJOT® thin sheet metal screws</p>	 <p>CO₂ injection pipe, curved with angled screw connection, pre-insulated</p>  <p>2 x Cable tie 200 mm with base, black</p>	 <p>Vent pipe Ø16, curved, with silicon hoses</p>  <p>10 x Cable tie 140mm, white</p>
-------------------------------------------------------------------------------------------------------------------------------------------------------------------------	------------------------------------------------------------------------------------------------------------------------------	---------------------------------------------------------------------------------------------------------------------------------------------------------------------------------------------------------------------------------------------------------------------------------------------------------------	-----------------------------------------------------------------------------------------------------------------------------------------------------------------------------------------------------------------------------------------------------------------

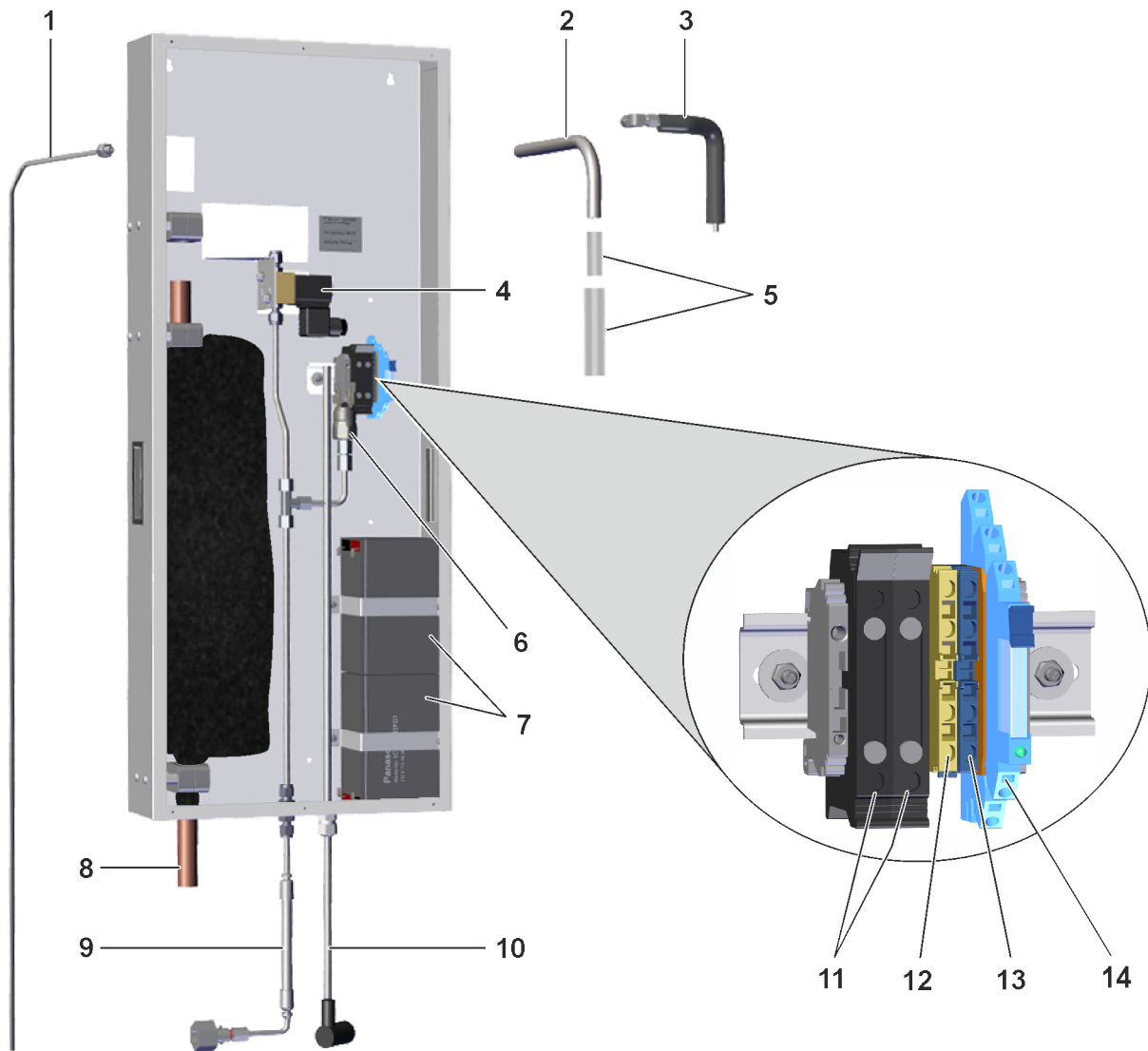



The connection tube (9) for the CO₂ gas cylinder is already connected with the CO₂-emergency cooling system. Do not remove this connection.



- | | |
|------------------------------------------------------------|-----------------------------------------------------|
| (1) Injection pipe Ø 6 mm | (8) Vent pipe Ø 22 mm |
| (2) Vent pipe Ø16 x 1,0 x 270 mm, curved | (9) Connection tube to CO ₂ gas cylinder |
| (3) Injection pipe CO ₂ , curved, pre-insulated | (10) Electrical connection cable |
| (4) Solenoid valve 12 V DC | (11) 2 x Fuse 4 A/250 V-F-6,32x32 mm |
| (5) Silicon hose, transparent Ø 16 | (12) 4-pole through terminal, beige |
| (6) Silicon hose, transparent Ø 20 | (13) 4-pole through terminal, blue |
| (7) 2 Battery packs 12 V, 7.2 Ah | (14) Relay (1W / 6 A) 12 V DC |



3.3 Installation

3.3.1 Mechanical installation

 	 DANGER
	<p>Electrical hazard during live maintenance and repair work Deadly electric shock.</p> <ul style="list-style-type: none">➤ Before conducting most of the described work, turn off the chamber at the main power switch and disconnect the power plug➤ Take all precautionary measures that a unit which is disconnected from the power supply will not be inadvertently connected to the power supply.

During work inside the chamber there is danger of frostbite as the inner parts can become very cold

	 CAUTION
	<p>Danger of injury by freezing on when touching very cold surfaces. Local frostbite.</p> <ul style="list-style-type: none">➤ Wear protective gloves.

 	 CAUTION
	<p>Danger of cutting by sharp edges of sheet metal parts. Cutting injuries.</p> <ul style="list-style-type: none">➤ Wear protective gloves during mounting and dismantling inner chamber and housing because sheet metal components may be sharp-edged.

1. Open the chamber door.
2. Disconnect the chamber from the power supply.
3. Allow the chamber to warm up with opened door to the ambient temperature.
4. Remove all shelves from the chamber.



5. Remove the cover on the inner chamber rear of the SUFsg.
6. Remove the Armaflex tube from the access port.

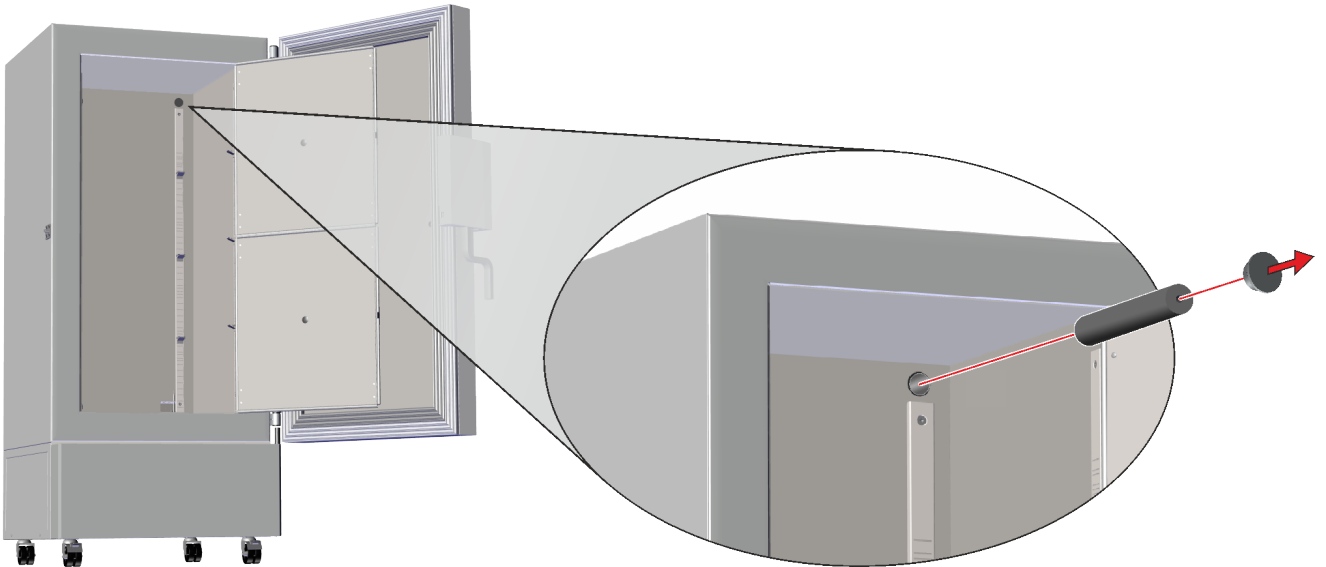

7. Screw two of the supplied EJOT® thin sheet metal screws **X** halfway into the rear panel of the SUFsg.
8. Remove the plug **Y** from the access port.

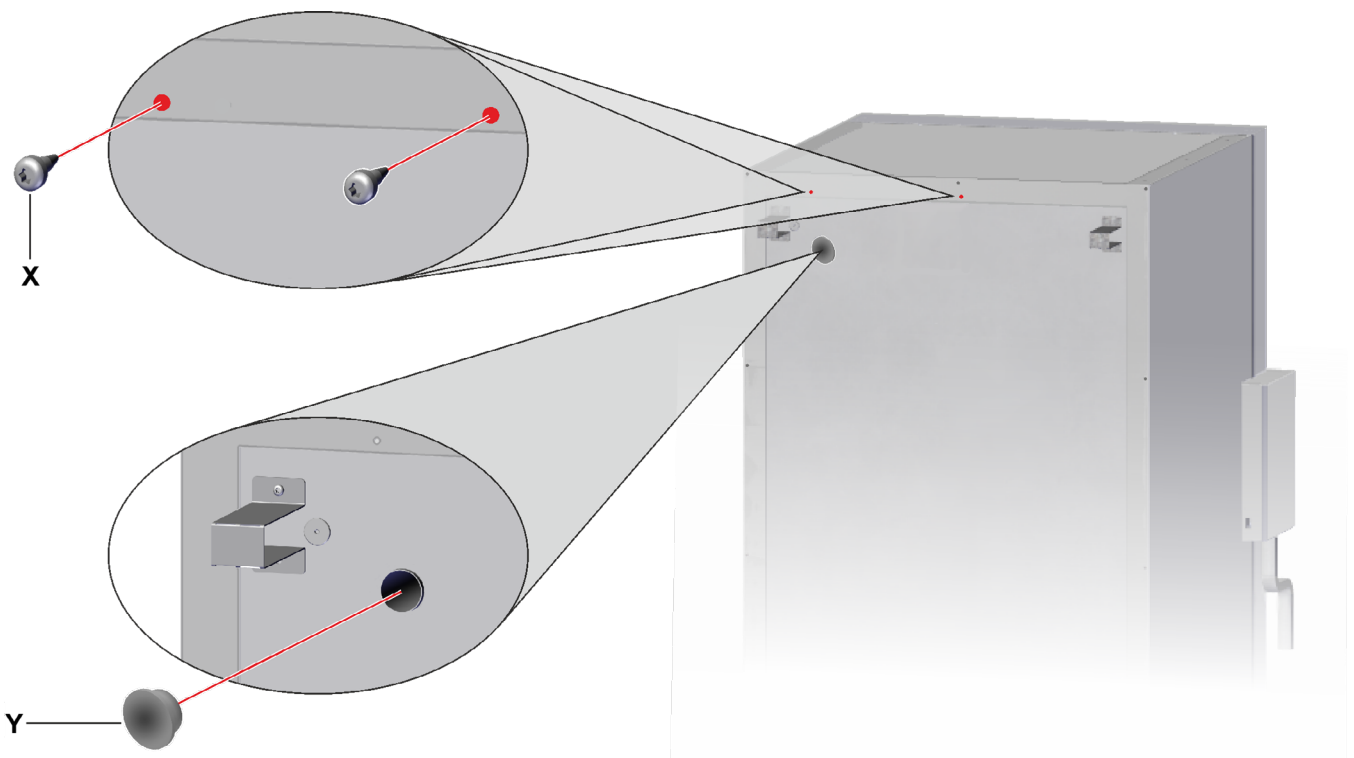

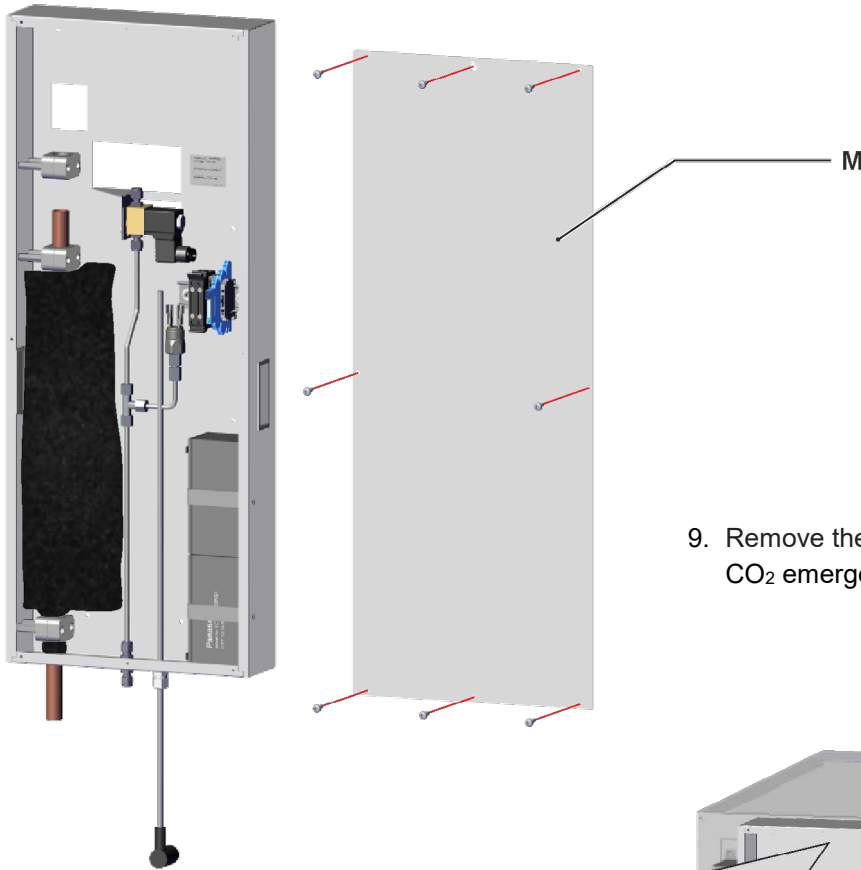

9. Remove the housing cover **M** of the CO₂ emergency cooling

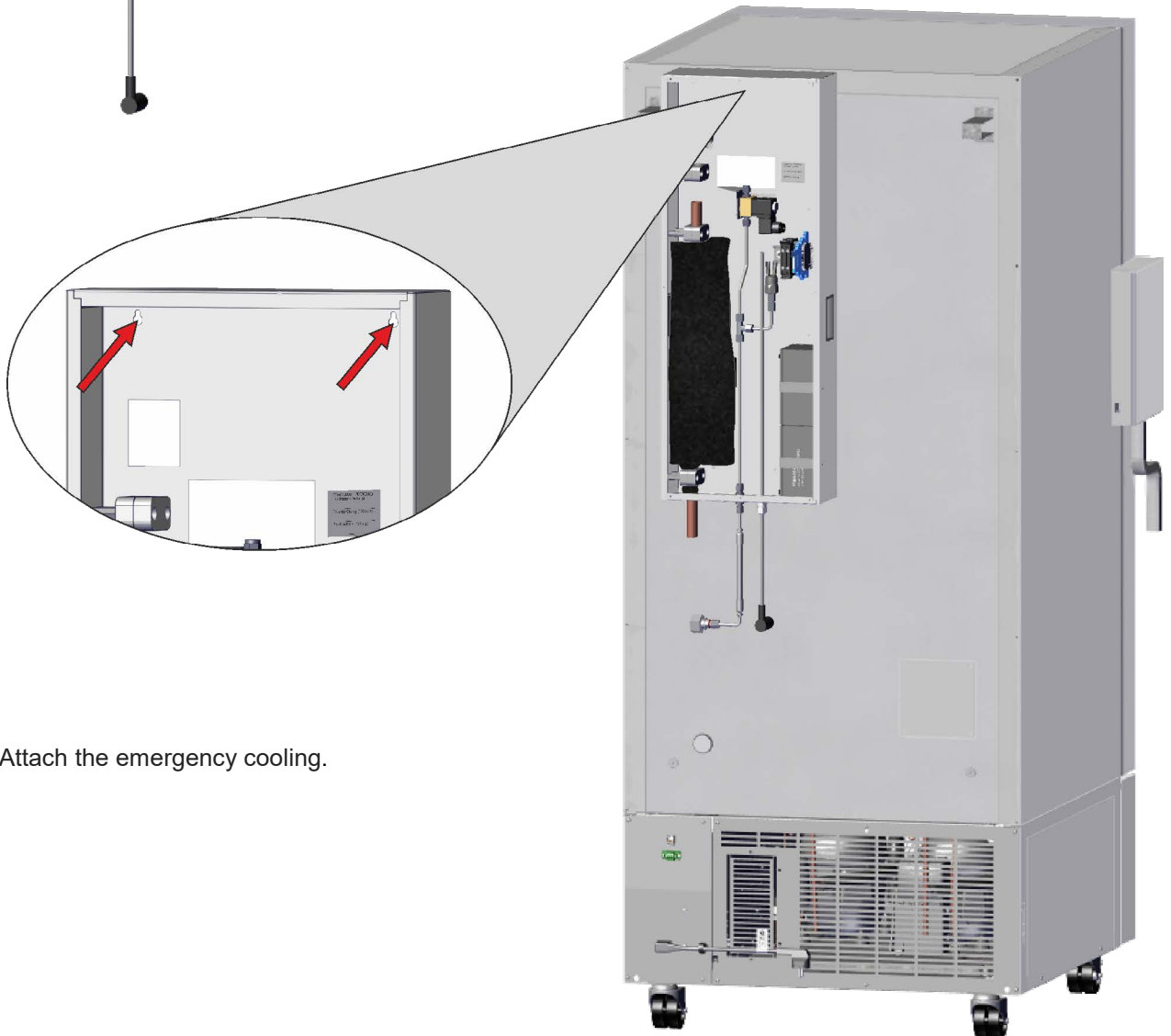

10. Attach the emergency cooling.

11. Fix the emergency cooling with another 4 EJOT® thin sheet metal screws **X**.
12. Tighten all the screws **X**.

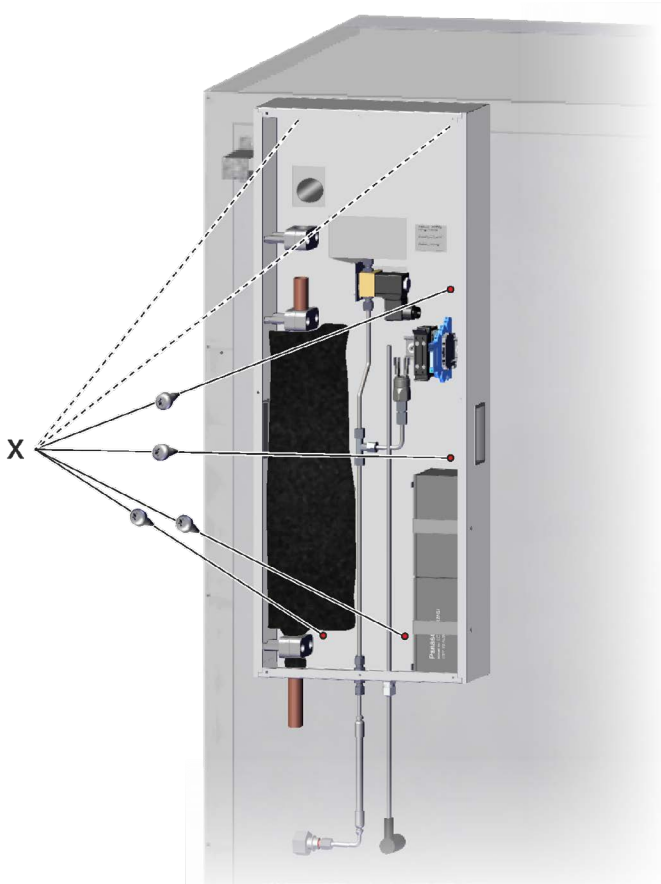

13. Open the upper pipe clamp with a 4 mm Allen wrench.

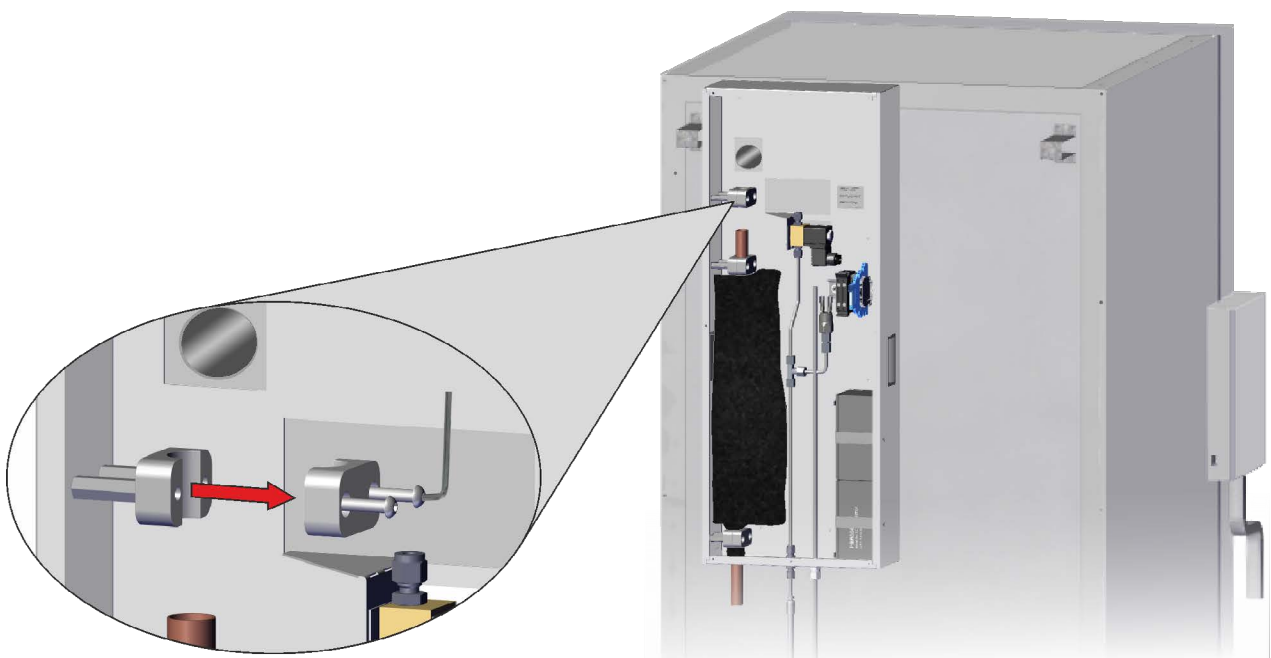

14. Guide the injection tube (1), (complete with union nut and cutting ring) from the inside through the access port.

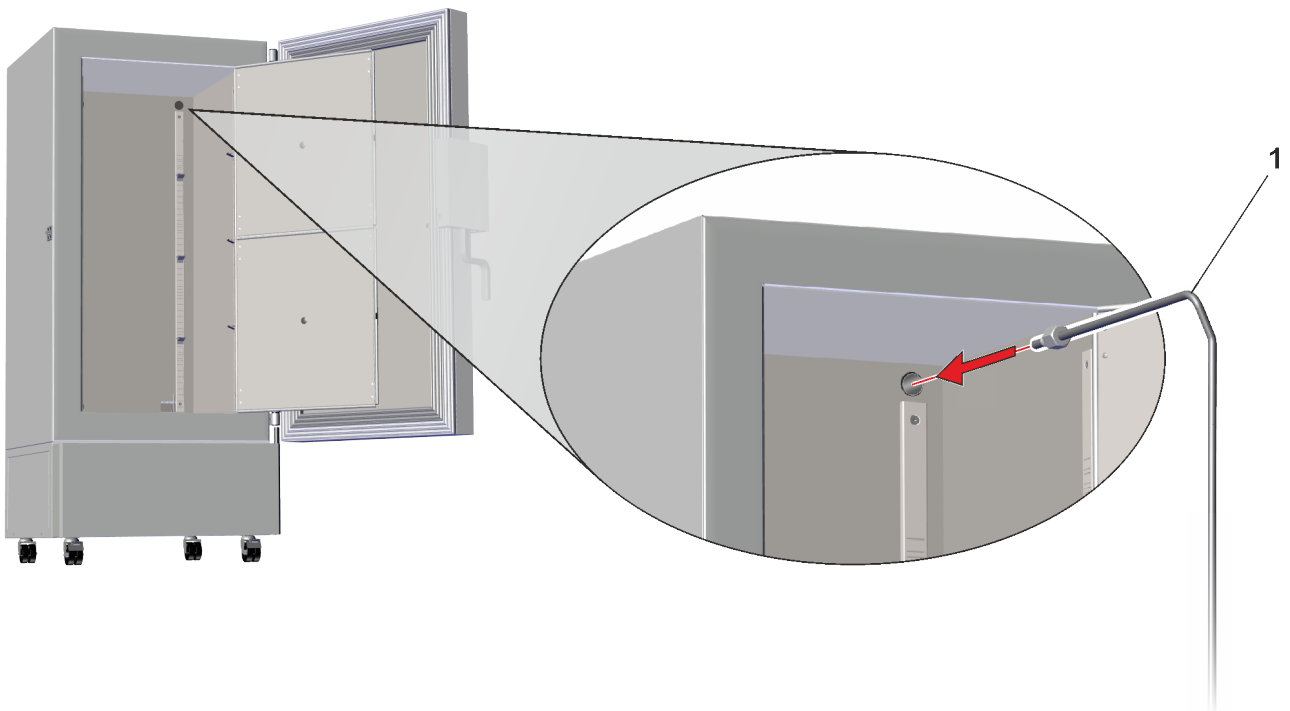

15. Slide the silicon hose R over the vent pipe (2). Then slide the silicon hose S over the hose R as shown.

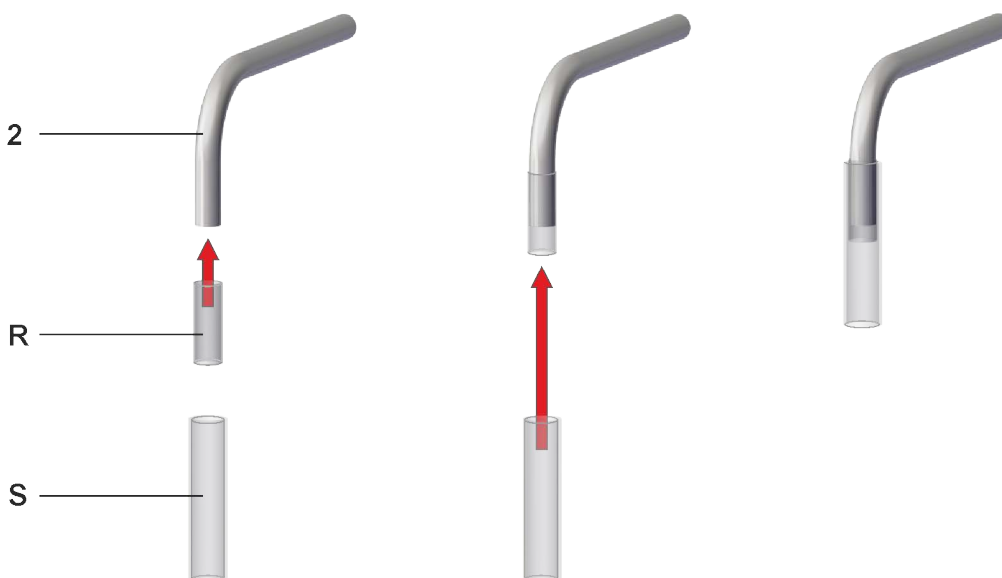

(2) Vent pipe $\text{Ø}16 \times 1,0 \times 270$ mm, curved

R Silicon hose, $\text{Ø} 16$ mm

S Silicon hose, $\text{Ø} 20$ mm

16. Feed the bend of the vent pipe through the access port in the emergency cooling housing.
17. Slide the silicon hose approx. 20 mm over the copper pipe.

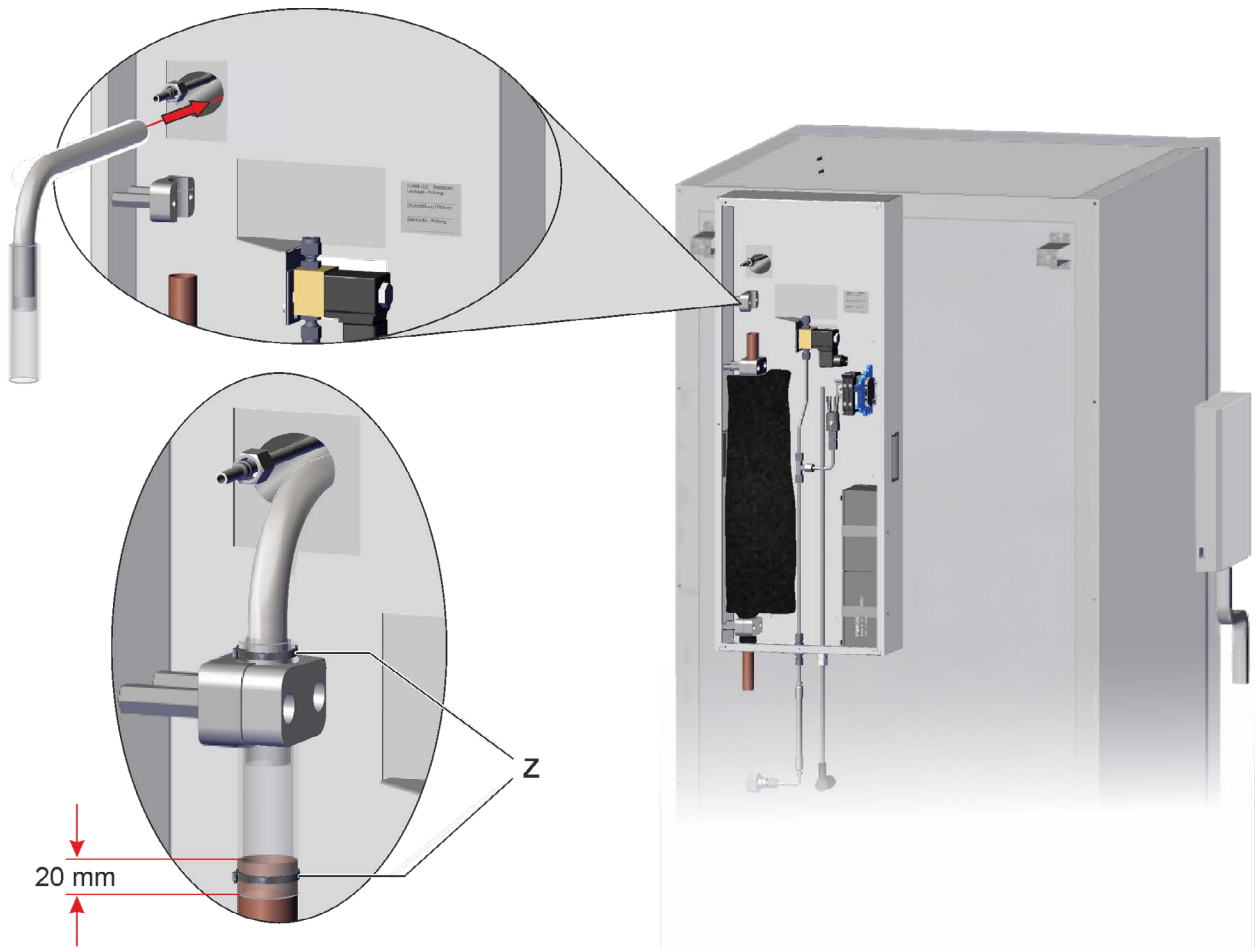

Z Cable tie, black

18. Reinstall the pipe clamp.
19. Secure the silicon hose **with the supplied black cable ties Z** once directly above the pipe clamp and once below the pipe clamp on the copper pipe.

20. Screw the pre-insulated, curved injection pipe (3), with the union nuts onto the injection pipe and the solenoid valve (4). Tighten the union nuts hand-tight and then turn them with the 14mm open-end wrench half a turn further.

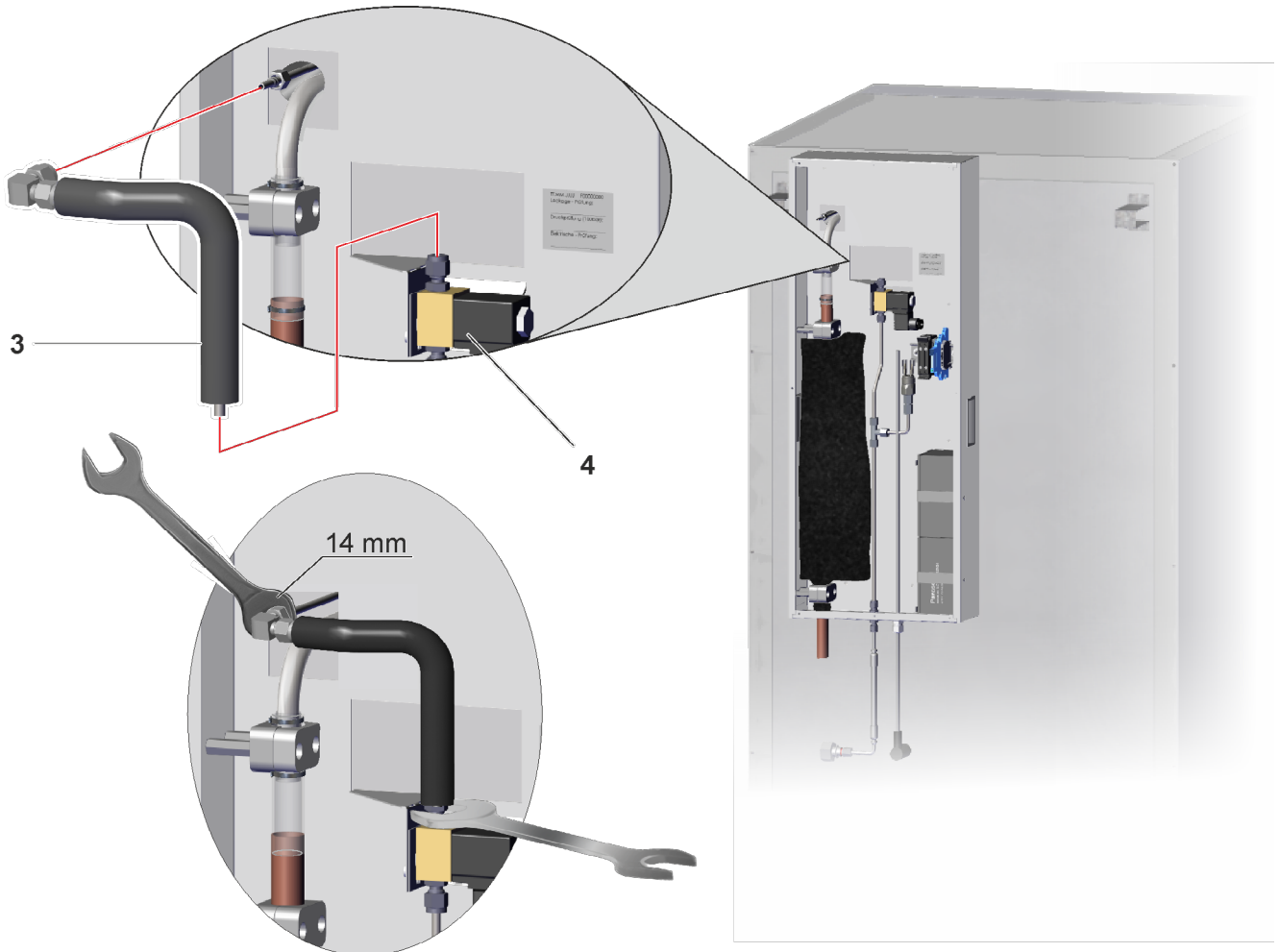

21. Seal the access port in the inner chamber with Terostat IX.



22. Insulate the pipes and silicon hoses in the emergency cooling housing with the supplied fitting Armaflex insulating tubes.

23. Cover the components around the access port with adhesive tape (not included) for protection.

24. Then fill the access port from the rear with 2k PUR foam (not included).



25. Cut off the excess PUR foam with a knife after approx. 20 minutes.

26. Remove any residue with a vacuum cleaner from the housing.

27. Finally, wrap the transitions with the Armaflex insulating tape.

3.3.2 Electrical connection

Electrical components

7-pole panel connector

1. Remove the right machine room cover **A**.

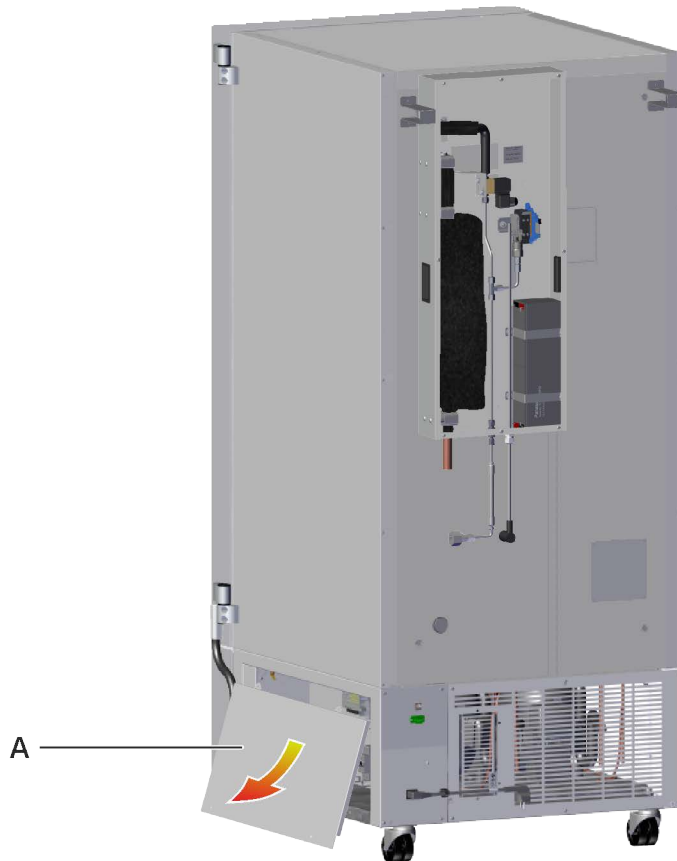

A Right machine room cover

2. Use a knife to cut the foil for the port of the panel connector **J** in the connection plate.

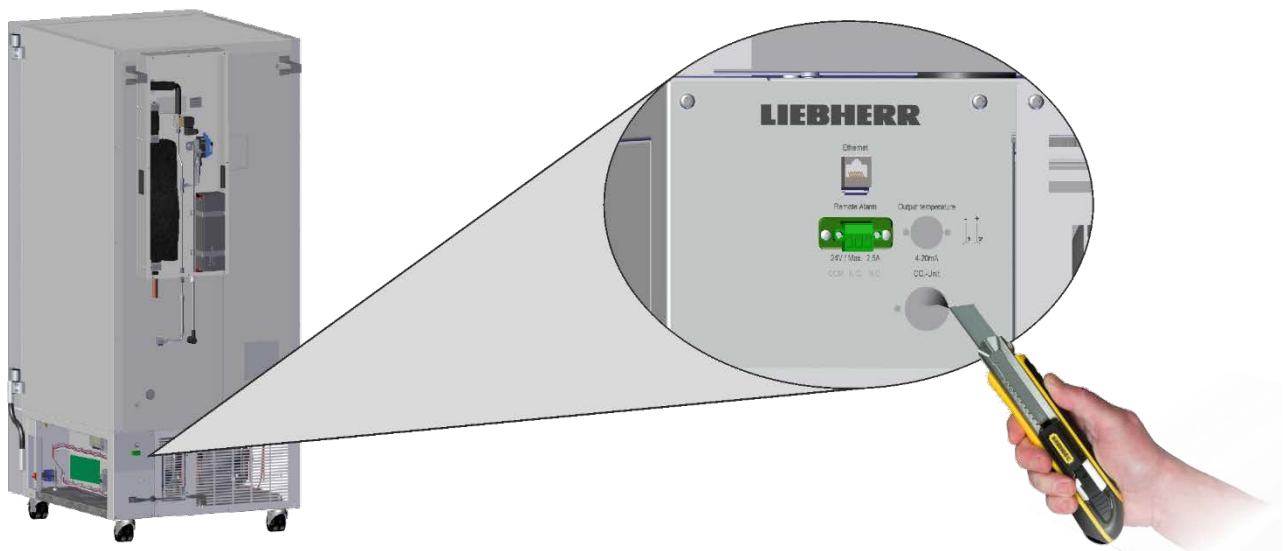

3. Insert the panel connector **J** and fix it by screwing.

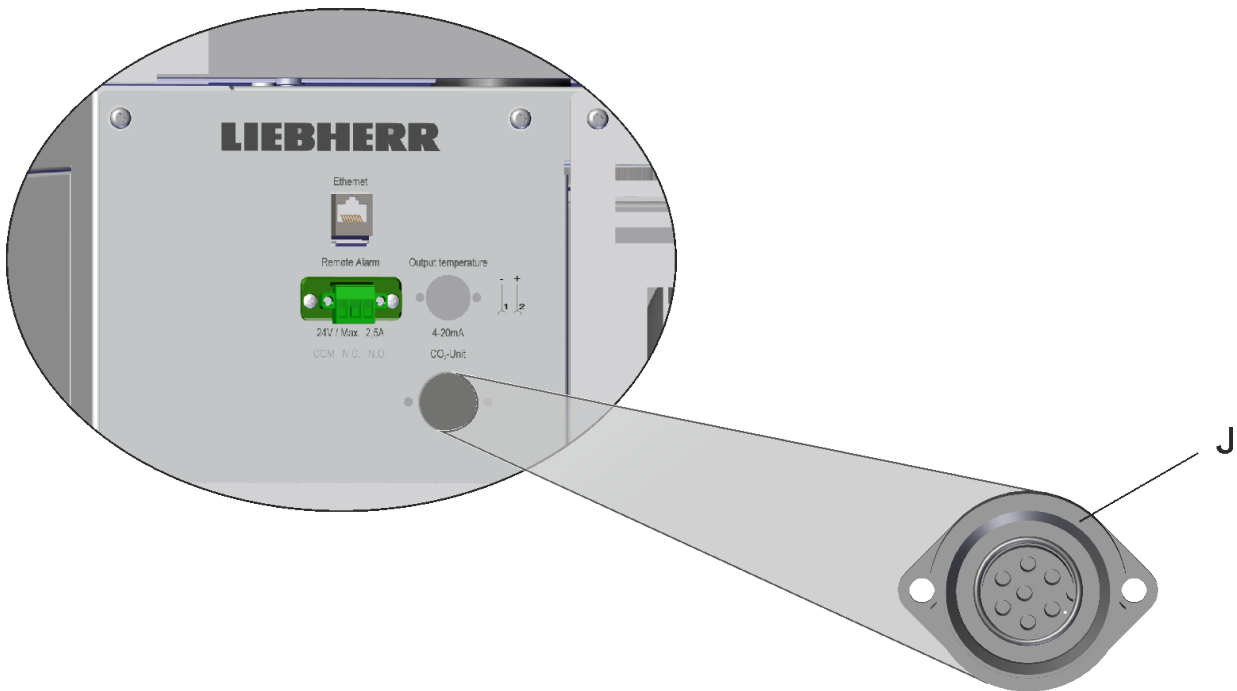

4. Wire all components (panel connector **(-X101)** and controller board) according to the circuit diagram.

Binary input for emergency cooling

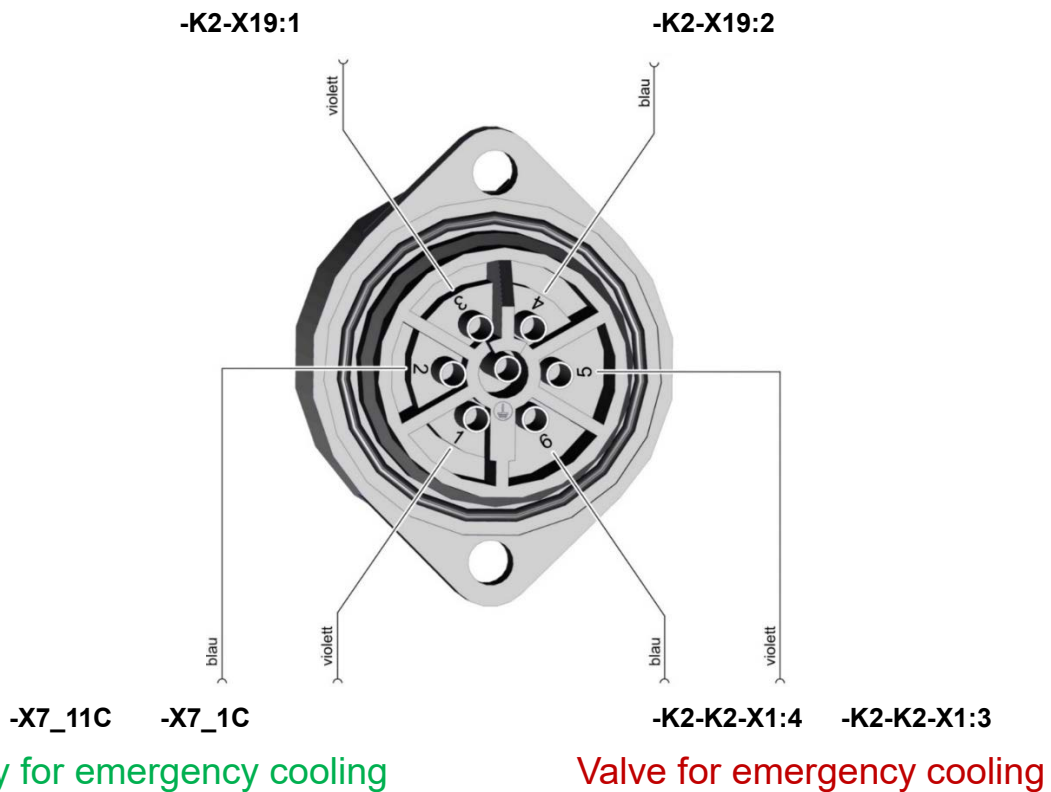

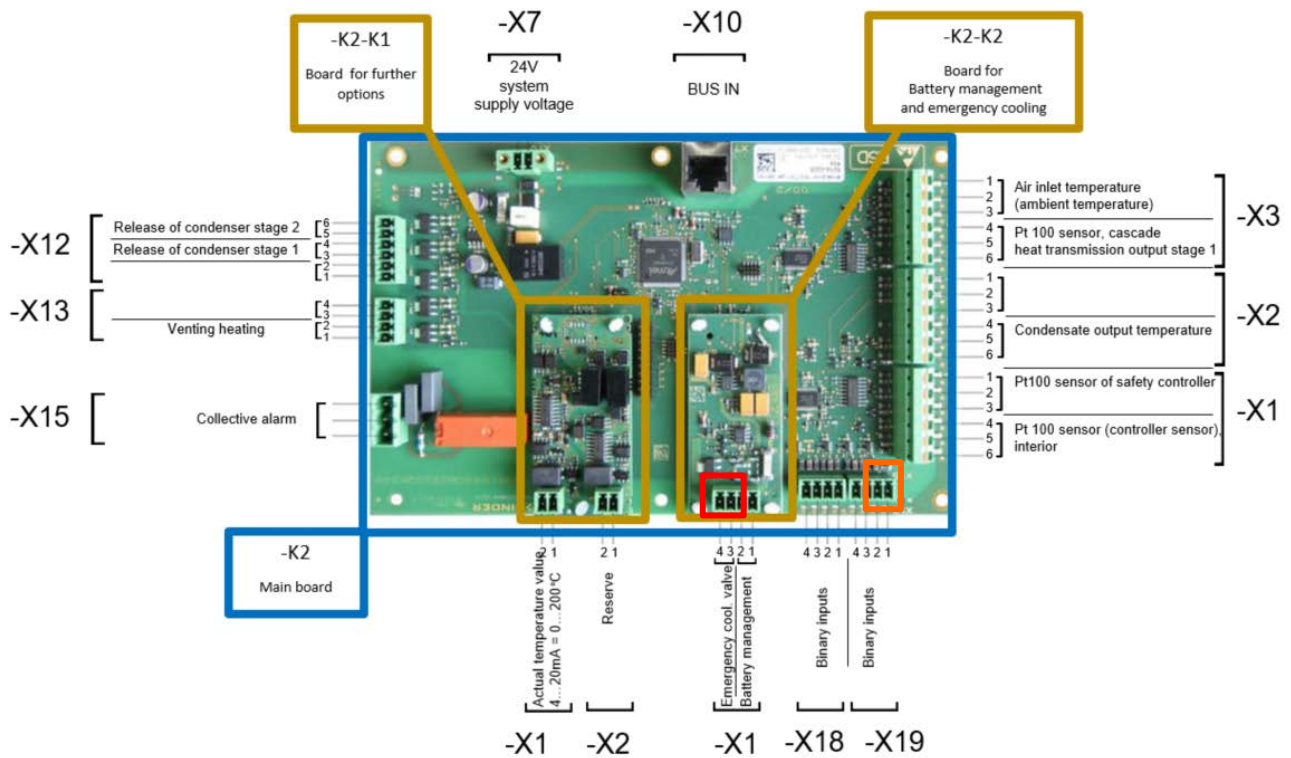

5. Fix the cables with the supplied white cable ties.

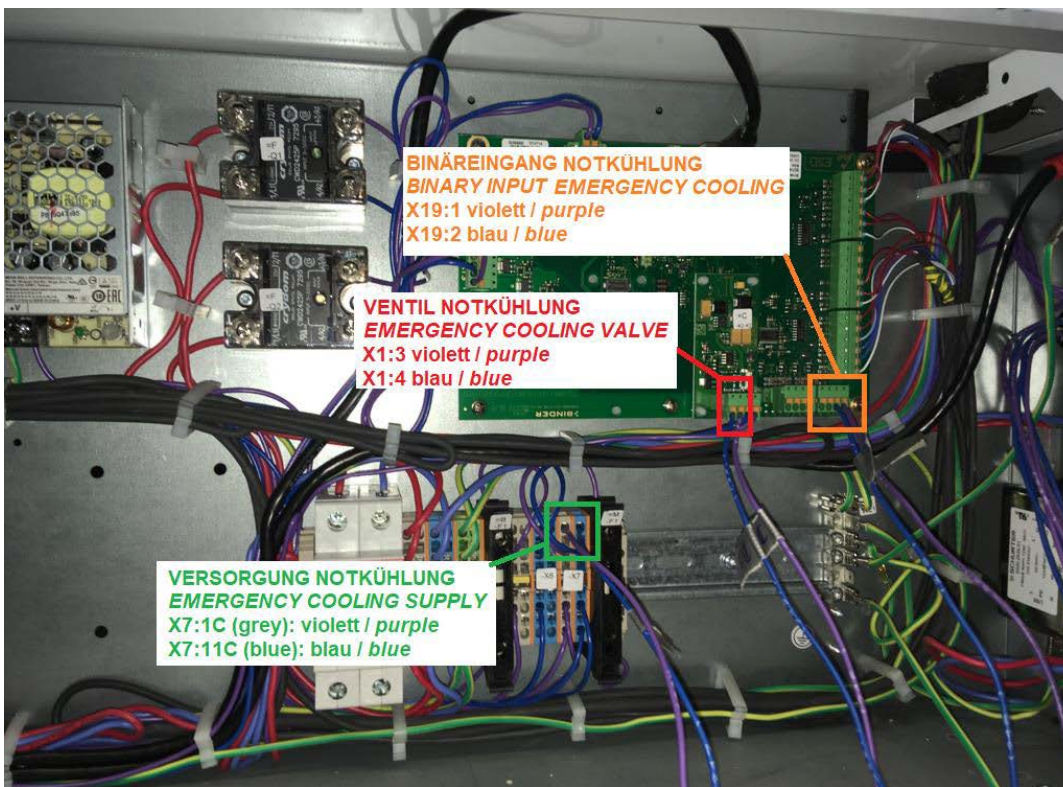

6. Connect the plug of the connection cable (10) from the CO₂ emergency cooling into the panel connector in the connection plate. This way the connection to the CO₂ emergency cooling is established.

7. Screw the housing cover **M** on the CO₂ emergency cooling.
8. Mount the right machine room cover **A**.

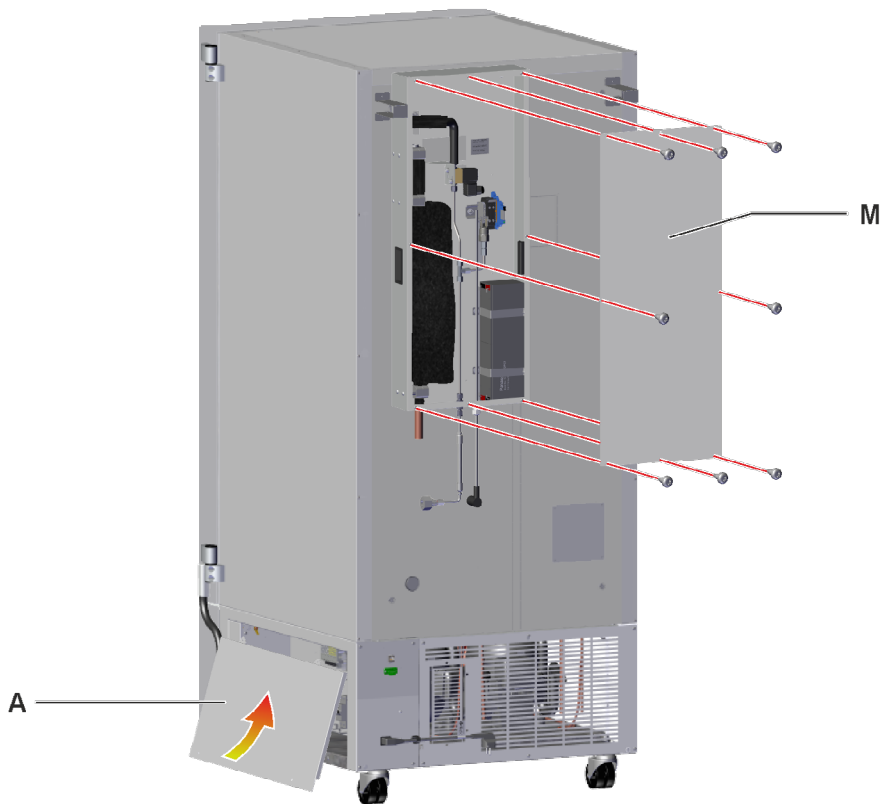

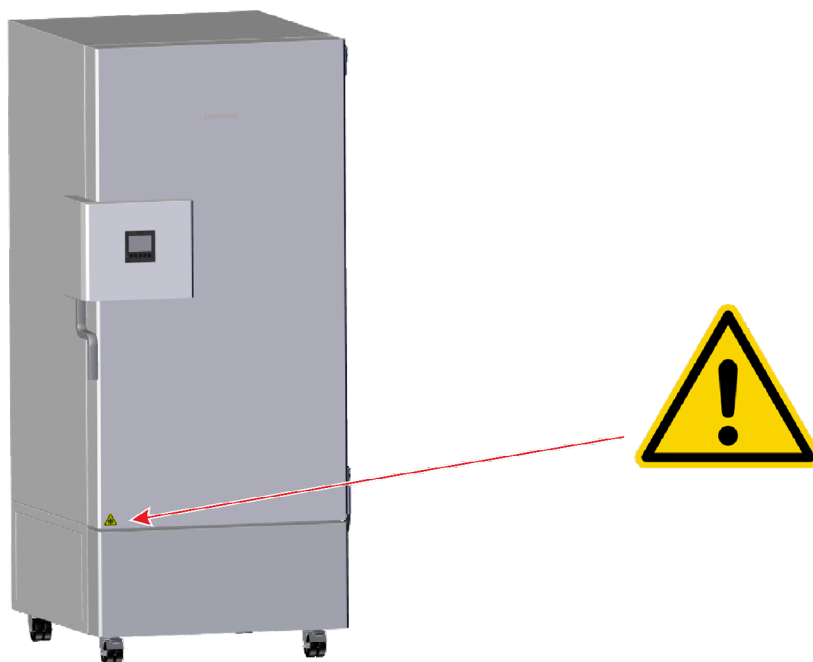

- M** Housing cover of the emergency cooling
- A** Right machine room cover

9. Finally stick the supplied warning label on the chamber door.



3.4 Leak detection

Precautions when handling gas cylinders:

	 WARNING
	<p>Risk of injury through sudden release of the stored pressure energy when the valve safety is torn off.</p> <p>Injuries. Local frostbite.</p> <ul style="list-style-type: none">➤ Secure gas cylinders against falling (by chaining it).➤ Transport gas cylinders with a cylinder cart.➤ Open the gas cylinder valve slowly to avoid pressure surges.➤ Observe relevant regulations for dealing with gas cylinders.

	<p>Even when CO₂ or systems operated with CO₂ are handled carefully and appropriately, a residual risk remains, which can lead to life-threatening situations under certain circumstances.</p> <p>Therefore, we strongly recommend continuous monitoring of the CO₂ concentration in the ambience of the CO₂ emergency cooling.</p> <p>The maximum permissible occupational exposure limit for CO₂ (0,5 Vol.-% CO₂ for Germany) must never be exceeded.</p>
-----------------------------------------------------------------------------------	-------------------------------------------------------------------------------------------------------------------------------------------------------------------------------------------------------------------------------------------------------------------------------------------------------------------------------------------------------------------------------------------------------------------------------------------------------------------------------------------------------------------------------



Connection of the CO₂-pressure cylinder



DANGER

Danger of suffocation and poisoning by high concentration of CO₂ (> 4 Vol.-%).

Death by suffocation.

- Operate the CO₂ emergency cooling only in a well-ventilated room.
- Install a suitable conduct at the CO₂ outlet of the emergency cooling system
- Observe the relevant regulations for handling CO₂.
- Comply with the occupational exposure limit
- Close the CO₂ supply when decommissioning the chamber.

1. Connect the hose to the CO₂-pressure cylinder.
2. Open the valve of the CO₂-pressure cylinder.
3. Check all fittings of the gas inlet for tightness with gas detection spray.



Check the gas fittings after connection with gas detection spray for leaks. The hose connection must be tight. Before installing or disconnecting the gas hose, the valve of the CO₂ pressure cylinder must be closed.



Please note

Even small leaks for a prolonged period of time decrease the content of the CO₂-pressure cylinder. To ensure the operational readiness of the emergency cooling system it is recommended to check up at regular intervals the capacity of the CO₂ pressure cylinder.

3.5 Function test

1. Connect the chamber to the power supply.
2. Turn on the chamber.
3. Activate the emergency cooling and take into account the exact chamber designation:

For chambers with index 70A:

Go to Liparts under the Download category of the respective chamber type, download the configuration file for CO₂ and save it on a USB stick.

The configuration file must then be imported. See the description in chap. 17.2. of the operating manual for the Ultra Low Temperature Freezer (German: 7085 837-00, English: 7085 838-00, French: 7085 839-00, other languages 7085 842-00).

For chambers from index 70B:

The configuration for CO₂ is already included on the controller and only needs to be activated. See the description in chap. 20.3.2 of the operating manual for the Ultra Low Temperature Freezer (German: 7085 954-00, English: 7085 955-00, French: 7085 956-00, other languages 7085 957-00).



On activation and deactivation of CO₂ emergency cooling a restart of the controller is necessary. For this turn off the power switch for 10 seconds.

Further information for activation and deactivation as well as the testing of the CO₂ emergency cooling, refer to the operating manual supplied with the device.



Liebherr-Hausgeräte GmbH
Memminger Straße 77-79
88416 Ochsenhausen
Germany
home.liebherr.com
