

---

# ICNh 5103

---

Integrated fridge-freezer with  
EasyFresh and NoFrost  
O Pure

# LIEBHERR

Fully Integrated



Fully Integrated

**LIEBHERR**

# ICNh 5103

Integrated fridge-freezer with  
EasyFresh and NoFrost

○ Pure

**G** Made  
in Germany



↑  
**178**  
↓



Type	Fixed door / Built-in appliance for integrated use
Energy consump. in 365 days/24 h	175 / 0.479 kWh
Volume	Freezer compartment: 70 l
Noise output	34 dB(A)
Climate rating	SN-T (+10 °C to +43 °C)
Frequency / voltage	50-60 Hz / 220-240 V~
Connection Rating	1.4 A 183 W
Aperture dimensions in cm (h / w / d)	177.2-178.8 / 56-57 / min. 55
<b>Controls</b>	
Type of Control	LC monochrome display, touch electronic
Interface	SmartDeviceBox: optional accessory
Door alarm	visual and acoustic
Alarm in case of malfunction	visual and acoustic
<b>Fridge compartment</b>	
Forced air system	PowerCooling with FreshAir activated charcoal filter
Door interior	Plastic door shelves with bottle holder
Interior light	LED ceiling lighting
<b>Freezer compartment</b>	
Number of drawers	3 drawers, VarioSpace
Freezing capacity in 24 hours	6 kg
Temperature rise time	9 h
<b>Features</b>	
Door hinges	Reversible door hinging
Replaceable door seal	yes
EAN-Nr.	4016803073352

## Features

---



### NoFrost

When you open your freezer, you want to see frozen food – and certainly not ice and frost. NoFrost protects the freezer compartment from unwanted icing, which consumes a lot of energy and can be expensive. NoFrost means no more tedious and time-consuming defrosting of the freezer compartment, more time for other things – and saving money.



### EasyFresh

The guarantee of market freshness in the home is our EasyFresh-Safe. Whether it's unpackaged vegetables or fruit, this ensures optimal storage for everything. Thanks to the air-tight closure, the food causes the humidity in the safe to rise. This keeps the food fresh for a long time.



### DuoCooling

DuoCooling uses two completely separate refrigeration circuits to ensure no air is exchanged between the fridge and freezer compartments. The food neither dries out nor is odour transferred. This means throwing less away, shopping less often, but saving more and greater enjoyment.



### Touch display

Fingertip control: the touch display enables easy and intuitive operation of your Liebherr. All functions are clearly arranged on the display. By gently tapping a finger, for example, you can easily select the functions or check the current temperature of your refrigerator.



### Space for baking tray

Do you want to keep that home-baked fruit pie fresh? Or maybe a prepared pizza to be baked later on? If so, simply slide your baking tray into your Liebherr -- it has plenty of space for storing a baking tray. Really convenient – you can slide the baking tray in and out when the door is opened at 90°.



### VarioSpace

Want to store a multi-layer ice cream cake safely until the summer party? No problem for your Liebherr freezer: Sometimes you just need more space and it's prepared for just that. With VarioSpace you can remove individual freezer drawers and the horizontal glass dividers below them, and hey presto, you have an extra large storage space.

# Technical drawing

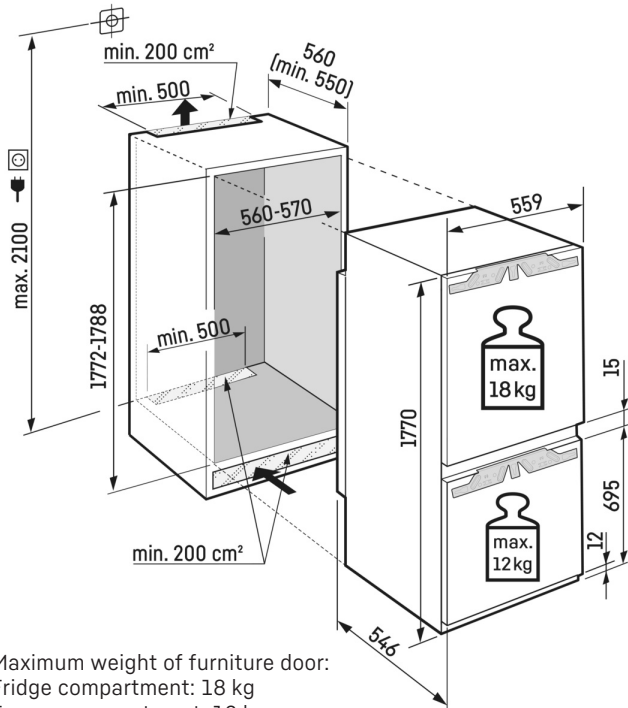

Maximum weight of furniture door:  
Fridge compartment: 18 kg  
Freezer compartment: 12 kg

Products and their details are staged for advertising purposes. Whilst every effort is made to ensure all specifications and information in this flyer are accurate, Liebherr reserves the right to make changes without notification. Where actual appliance measurements, specifications, and ratings are crucial, we recommend that the actual appliance installation instructions that accompany each appliance be checked. Liebherr will not be liable for any damage. (01.12.2022)

