

Operating and installation instructions

Upright refrigerator

EN

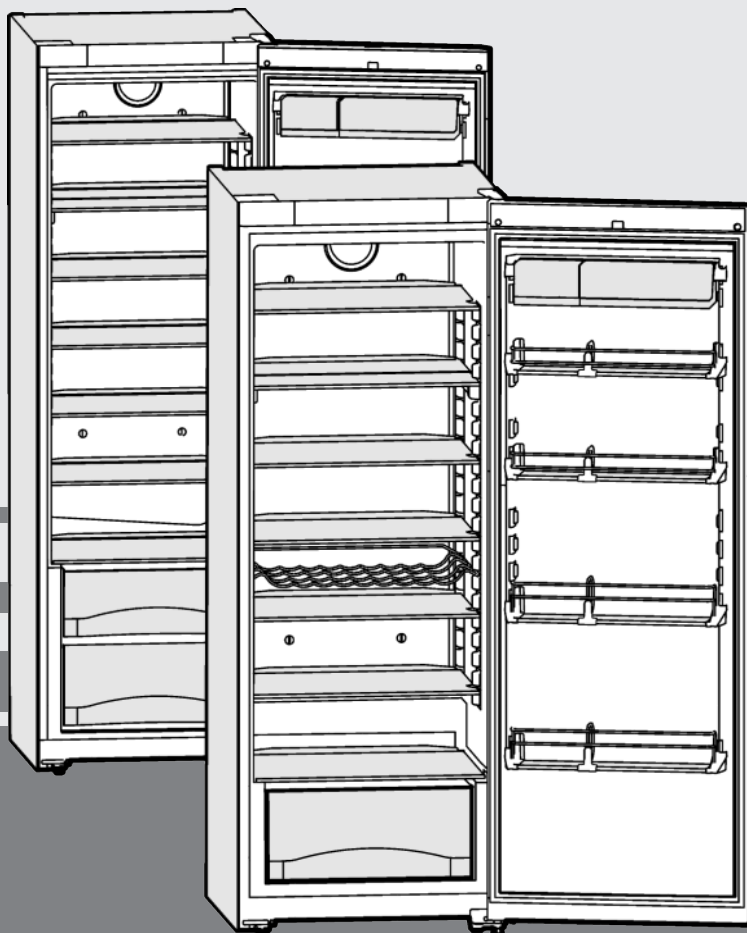

210417 **7085582 - 01**

(S)K(es/bs/ef) 36...42 ... 6

LIEBHERR

Appliance at a glance

Contents

1	Appliance at a glance	2
1.1	Description of appliance and equipment.....	2
1.2	Appliance range of use.....	2
1.3	Conformity.....	3
1.4	External dimensions of the appliance.....	3
1.5	Saving energy.....	3
1.6	HomeDialog.....	4
2	General safety information	4
3	Controls and displays	5
3.1	Operating and control elements.....	5
3.2	Temperature display.....	5
4	Putting into operation	5
4.1	Transporting the appliance.....	5
4.2	Installing the appliance.....	5
4.3	Changing over the door hinges.....	6
4.4	Insertion into a row of kitchen units.....	8
4.5	Disposing of packaging.....	8
4.6	Connecting the appliance.....	8
4.7	Switching on the appliance.....	9
5	Control	9
5.1	Brightness of the temperature display.....	9
5.2	Child proofing.....	9
5.3	Door alarm.....	9
5.4	Food refrigeration.....	9
5.5	Setting the temperature.....	9
5.6	SuperCool.....	10
5.7	Fan.....	10
5.8	Shelves.....	10
5.9	Using the sectioned shelf.....	10
5.10	Door racks.....	10
5.11	Removing the bottle holder.....	11
5.12	Vegetable bins.....	11
6	Maintenance	11
6.1	Cleaning the appliance.....	11
6.2	Customer service.....	12
7	Malfunctions	12
8	Decommissioning	13
8.1	Switching off the appliance.....	13
8.2	Taking the appliance out of service.....	13
9	Disposing of the appliance	13

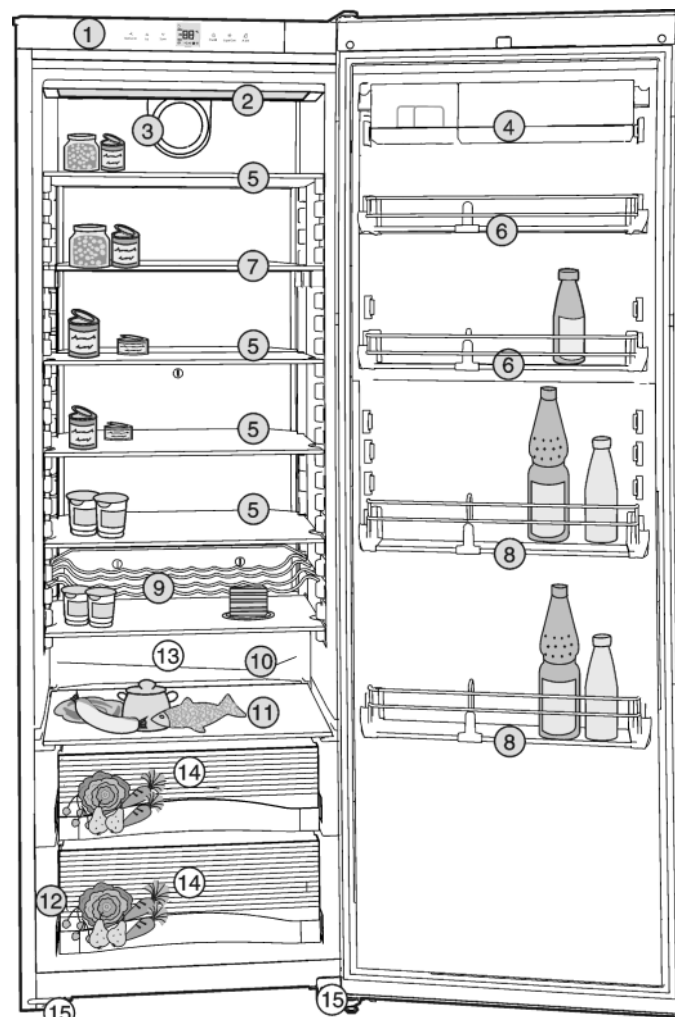

Fig. 1

- | | |
|--------------------------------------------|-------------------------------|
| (1) Operating panel | (9) Bottle shelf* |
| (2) Ceiling light | (10) Defrost water channel |
| (3) Fan | (11) Glass shelf |
| (4) Box shelves, removable | (12) Type plate |
| (5) Glass shelves, relocatable | (13) Coldest zone |
| (6) Door rack for tinned food, relocatable | (14) Vegetable compartment |
| (7) Glass shelf, sectioned, relocatable | (15) Height-adjustable foot * |
| (8) Door rack for bottles, relocatable | |

The manufacturer works constantly on the further development of all the types and models. Therefore please understand that we have to reserve the right to make design, equipment and technical modifications.

To get to know all the benefits of your new appliance, please read the information contained in these instructions carefully.

The instructions apply to several models. Differences may occur. Text relating only to specific appliances is marked with an asterisk (*).

Instructions for action are marked with a ►, the results of action are marked with a ▷.

1 Appliance at a glance

1.1 Description of appliance and equipment

Note

- Place food inside the appliance as shown in the diagram. This allows the appliance to save energy during operation.
- Shelves, drawers and baskets are arranged for optimum energy efficiency on delivery.

1.2 Appliance range of use

Intended use

The appliance is only suitable for refrigerating food in a domestic or domestic-like environment. This includes, for example, using

- in staff kitchens, bed and breakfast establishments,
- by guests in country houses, hotels, motels and other accommodation,
- for catering and similar services in the wholesale trade.

All other types of use are not permitted.

Foreseeable misuse

The following applications are expressly forbidden:

- Storing and refrigerating medicines, blood plasma, laboratory preparations or similar substances and products based on the Medical Device Directive 2007/47/EC
- Use in areas at risk of explosions

Misusing the appliance may lead to damage to the goods stored or they may spoil.

Climate classifications

Depending on the climate classification the appliance is designed to operate in restricted ambient temperatures. The climate classification applying to your appliance is printed on the rating plate.

Note

- Keep to the specified ambient temperatures in order to guarantee that the appliance works properly.

Climate classification	for ambient temperatures of
SN	10 °C to 32 °C
N	16 °C to 32 °C
ST	16 °C to 38 °C
T	16 °C to 43 °C

1.3 Conformity

The refrigerant circuit has been tested for leaks. This appliance complies with the applicable safety stipulations and with directives 2014/35/EU, 2014/30/EU, 2009/125/EG, 2011/65/EU and 2010/30/EU.

1.4 External dimensions of the appliance

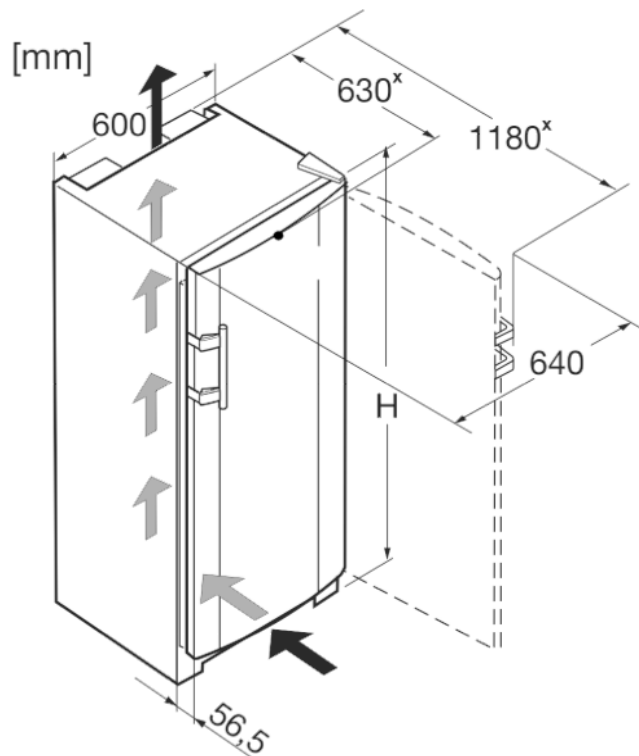

Fig. 2

Name	H (mm)
K(es) 36.., SK(es) 36..	1655
K(es) 42.., SK(es/ef) 42..	1852

^x For appliances supplied with wall spacers, the measurement increases by 35 mm (see 4.2) .

1.5 Saving energy

- Pay attention to good ventilation. Do not cover ventilation holes or grids.
- Always keep the fan air slits clear.
- Do not install the appliance in direct sunlight, next to an oven, radiator or similar.
- Energy consumption is dependent on the installation conditions, e.g. ambient temperature (see 1.2) . If the ambient temperature deviates from the standard temperature of 25°C, the energy consumption may differ.
- Open the appliance for as short a time as possible.
- The lower the temperature is set the higher the energy consumption.
- Sort food before arranging (see Appliance at a glance).
- Store all food well packaged and covered. A build up of frost is avoided.
- Only take food out for as long as necessary so that it doesn't warm up too much.
- Inserting hot food: let it cool to room temperature first.

Dust deposits increase energy consumption:

- For refrigerators with heat exchangers dust the metal grid on the back of the appliance once a year.

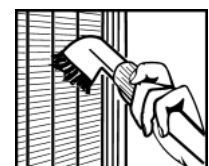

General safety information

1.6 HomeDialog

Depending on model and options, the HomeDialog system can be used to network a number of Liebherr appliances (situated, for example, in the basement) with a main appliance (sited, for example, in the kitchen) and control them via the latter. You will find more information on the benefits, requirements and principle of operation on the internet at www.liebherr.com.



2 General safety information

Danger for the user:

- This device can be used by children and people with impaired physical, sensory or mental abilities or with a lack of experience and knowledge provided that they are supervised or have received instruction in the safe use of this device, and about the resulting hazards. Children must not play with this appliance. Cleaning and user maintenance work must not be carried out by children without adult supervision. Children aged between 3 and 8 are allowed to load and unload the appliance. Children below the age of 3 must be kept away from the appliance unless they are under continuous adult supervision.
- When disconnecting the appliance from the supply, always take hold of the plug. Do not pull the cable.
- In the event of a fault pull out the mains plug or deactivate the fuse.
- Do not damage the mains power cable. Do not operate the appliance with a defective mains power cable.
- Have any repairs to or intervention in the appliance, and any change of the mains power cable, carried out by the customer service only or by other specialised personnel trained for the purpose.
- Only assemble, connect and dispose of the appliance according to the instructions.
- Please keep these instructions in a safe place and pass them on to any subsequent owners.
- Special-purpose lamps (incandescent lamps, LEDs, fluorescent tubes) in the appliance serve to illuminate the appliance interior and are not suited for room illumination.

Fire hazard:

- The refrigerant R 600a is environmentally friendly but flammable. Escaping refrigerant may ignite.
 - Do not damage the refrigerant circuit pipes.
 - Do not allow naked flames or ignition sources to enter the appliance.

- Do not use any electrical appliances in the interior (e.g. steam cleaners, heaters, ice cream maker etc.).
- If refrigerant escapes: remove any naked flames or sources of ignition from the leakage area. Ventilate the room well. Notify the after-sales service.
- Do not store explosives or sprays using combustible propellants such as butane, propane, pentane, etc. in the appliance. To identify these spray cans, look for the list of contents printed on the can, or a flame symbol. Gases possibly escaping may ignite due to electrical components.
- Keep burning candles, lamps and other items with naked flames away from the appliance so that they do not set the appliance on fire.
- Please be sure to store alcoholic drinks or other packaging containing alcohol in tightly closed containers. Any alcohol that leaks out may be ignited by electrical components.

Danger of tipping and falling:

- Do not misuse the plinth, drawers, doors etc. as a step or for support. This applies particularly to children.

Danger of food poisoning:

- Do not consume food which has been stored too long.

Danger of frostbite, numbness and pain:

- Avoid lasting skin contact with cold surfaces or refrigerated/frozen food or take protective steps, e.g. wear gloves. Do not consume ice cream, water ice or ice cubes immediately and do not consume them too cold.

Danger of injury and damage:

- Hot steam can lead to injury. Do not use electrical heating or steam cleaning equipment, open flames or defrosting sprays to defrost.
- Do not use sharp implements to remove the ice.

Danger of crushing:

- Do not hold the hinge when opening and closing the door. Fingers may get caught.

Symbols on the appliance:



The symbol can be located on the compressor. It refers to the oil in the compressor and indicates the following danger: Swallowing or inhaling can be fatal. This is only relevant for recycling. There is no danger in normal operation.

Please observe the specific information in the other sections:

	DANGER	identifies a situation involving direct danger which, if not obviated, may result in death or severe bodily injury.
	WARNING	identifies a dangerous situation which, if not obviated, may result in death or severe bodily injury.
	CAUTION	identifies a dangerous situation which, if not obviated, may result in minor or medium bodily injury.
	NOTICE	identifies a dangerous situation which, if not obviated, may result in damage to property.
	Note	identifies useful information and tips.

3 Controls and displays

3.1 Operating and control elements

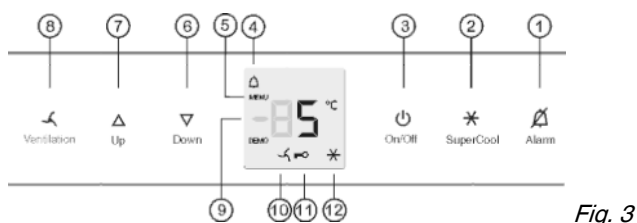

Fig. 3

- (1) Alarm button
- (2) SuperCool button
- (3) On/Off button
- (4) Alarm symbol
- (5) Menu symbol
- (6) Down setting button
- (7) Up setting button
- (8) Fan button
- (9) Temperature display
- (10) Fan symbol
- (11) Child-proofing symbol
- (12) SuperCool symbol

3.2 Temperature display

During normal operation, the display shows:

- the average cooling temperature

The following displays indicate a fault. Possible causes and solutions: (see Malfunction).

- F0 to F9

4 Putting into operation

4.1 Transporting the appliance

CAUTION

Risk of injury and danger of damage as a result of incorrect transport!

- ▶ Transport the appliance in a packed condition.
- ▶ Transport the appliance upright.
- ▶ Do not transport the appliance without assistance.

4.2 Installing the appliance

WARNING

Fire hazard due to dampness!

If live parts or the mains lead become damp this may cause short circuits.

- ▶ The appliance is designed for use in enclosed areas. Do not operate the appliance outdoors or in areas where it is exposed to splash water or damp conditions.

WARNING

Risk of fire due to short circuit!

If the mains cable/connector of the appliance or of another appliance touch the rear of the appliance, the mains cable/connector may be damaged by the appliance vibrations, leading to a short circuit.

- ▶ Stand the appliance so that it is not touched by connectors or main cables.
- ▶ Do not plug the appliance or any others into sockets located near the rear of the appliance.

WARNING

Fire hazard due to refrigerant!

The refrigerant R 600a is environmentally friendly but flammable. Escaping refrigerant may ignite.

- ▶ Do not damage the piping of the refrigeration circuit.

WARNING

Fire hazard and danger of damage!

▶ Do not place appliances emitting heat e.g. microwaves, toasters etc. on the appliance!

WARNING

Blocked ventilation openings pose a risk of fire and damage!

- ▶ Always keep the ventilation openings clear. Always ensure that the appliance is properly ventilated!

NOTICE

Risk of damage due to condensate!

If your appliance is not a Side-by-Side (SBS) appliance:

- ▶ do not install the appliance directly alongside a further refrigerator/freezer.

- In the event that the appliance is damaged, contact the supplier immediately before connecting to the mains.
- The floor at the site must be flat and level.
- Do not install the appliance in a location where it is exposed to direct radiation of the sun, next to a cooker, heater and similar.
- Always stand the appliance backed directly to the wall using the enclosed wall spacers (see below).
- The appliance may be moved only when it is empty.
- The surface supporting the appliance must be at the same level as the surrounding floor.
- Do not install the appliance without assistance.
- The more R 600a refrigerant there is in the appliance, the larger the room in which the appliance is standing needs to be. In rooms that are too small, a flammable mix of gas and air may be created if there is a leak. According to the EN 378 standard, every 11 g of R 600a refrigerant requires at least 1 m³ space in the room for the appliance. The amount of refrigerant in your appliance is on the type plate inside the appliance.

Putting into operation

- ▶ Detach the connecting cable from the rear of the appliance, removing the cable holder at the same time because otherwise there will be vibratory noise!
- ▶ Remove the protective film from the outside of the appliance.*

NOTICE*

The stainless steel doors are provided with a high-quality surface coating and must not be treated using the accompanying care product.



Otherwise the surface coating will be affected.

- ▶ Wipe the coated **door surfaces** using a soft, clean cloth only.
- ▶ Apply a stainless steel cleaner only to the **stainless steel side walls** evenly, wiping with the grain. Subsequent cleaning becomes easier as a result.
- ▶ Wipe **side walls with a paint finish** using a soft, clean cloth only.

- ▶ Remove the protective film from the decorative trims.*
- ▶ Remove all transit supports.

The spacers supplied with some appliances must be used to achieve the stated energy consumption. These will extend the depth of the appliance by approx. 35 mm. The appliance is fully functional if the spacers are not used, but does have a slightly higher energy consumption.

- ▶ In the case of an appliance with enclosed wall spacers, mount the wall spacers on the back of the appliance at the top left and right.

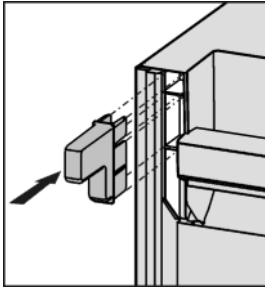

- ▶ Dispose of packaging material (see 4.5).
- ▶ Align the appliance so that it stands firmly and on a level by applying the accompanying spanner to the adjustable-height feet (A) and using a spirit level.
- ▶ Then support the door: Extend the adjustable foot at the turn hinge (B) until it rests on the floor and then make a further 90° turn.

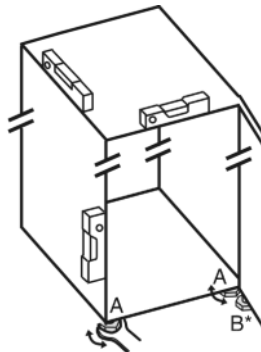

When a Side-by-Side appliance (S...) is fitted together with a second appliance (as a SBS combination):

- ▶ Proceed according to the Side-by-Side combined fridge-freezer installation instructions. (Accessories bag of the SBS freezer/appliance with freezer compartment)

Note

- ▶ Clean the appliance (see 6.1).

If the appliance is installed in a very damp environment, condensate may form on the outside of the appliance.

- ▶ Always see to good ventilation at the installation site.

4.3 Changing over the door hinges

You can change over the door hinges if necessary.

NOTICE

Risk of damage to side-by-side appliances due to condensation!

When a side-by-side appliance (S...) is fitted together with a second appliance (as a SBS combination), the door hinges must remain as delivered.

- ▶ Do not change over the door hinges.

Ensure that the following tools are to hand:

- Torx® 25
- Torx® 15
- Screwdriver
- Battery-powered screwdriver, if necessary
- Second person for fitting work, if needed
- Accompanying Allen key size 2*

4.3.1 Detaching the door

Note

- ▶ Remove any food from the door racks before removing the door, so that no food falls out.

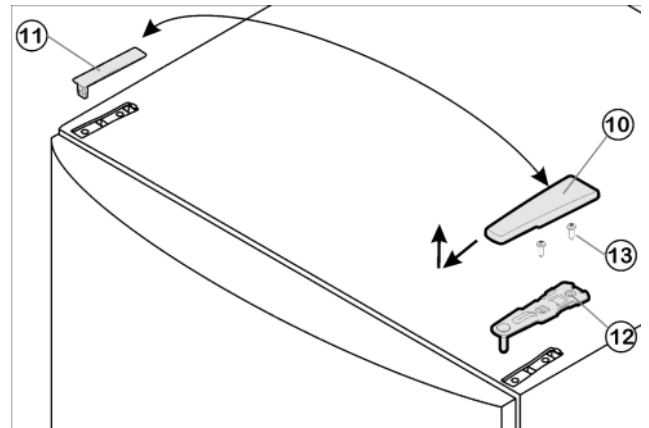

Fig. 4

- ▶ Close the door.
- ▶ Pull off the cover Fig. 4 (10) forwards and upwards.
- ▶ Lift off the cover Fig. 4 (11).



CAUTION

Risk of injury if the door tips!

- ▶ Take good hold of the door.
- ▶ Set down the door carefully.

- ▶ Unscrew the upper turn hinge Fig. 4 (12)(2x Torx® 25) Fig. 4 (13) and lift it off.
- ▶ Lift off the door and set it aside.

4.3.2 Distinguishing between bearing elements

Some appliances are height-adjustable, as can be noted from the bearing pin in the lower turn hinge:

- ▶ For appliances **without height adjustment**, continue with item (see 4.3.3).

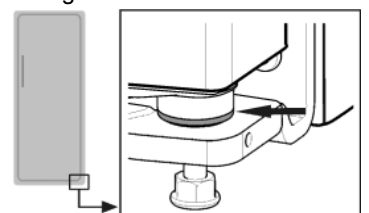

- ▶ For appliances with height adjustment, continue with item (see 4.3.4).

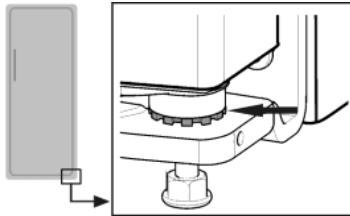

4.3.3 Changing the bearing parts

for appliances without height adjustment

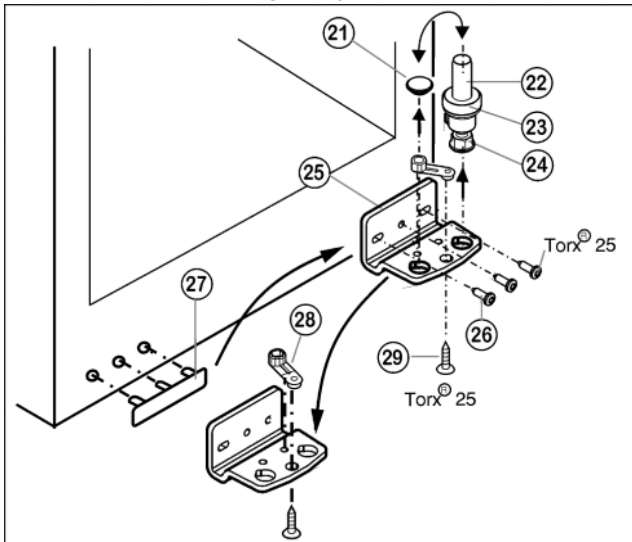

Fig. 5

- ▶ Lift out the bearing pin Fig. 5 (22) together with washer Fig. 5 (23) and adjustable-height foot Fig. 5 (24).
- ▶ Lift off the stopper Fig. 5 (21).
- ▶ Unscrew Fig. 5 (26) the turn hinge Fig. 5 (25).
- ▶ Unscrew Fig. 5 (29) the bearing element Fig. 5 (28), transfer it to the opposite location hole of the turn hinge and screw it firmly into place.
- ▶ Carefully lift off the cover on the handle side Fig. 5 (27) and transfer it to the opposite side.
- ▶ Screw the turn hinge Fig. 5 (25) firmly into place on the new hinge side, possibly using a cordless screwdriver (with 4 Nm).
- ▶ Re-insert the stopper Fig. 5 (21) into the other hole.
- ▶ Re-insert the bearing pin Fig. 5 (22) together with the washer and adjustable-height foot. In so doing, pay attention that the locating lug points backwards

4.3.4 Changing the bearing parts

For appliances with height adjustment

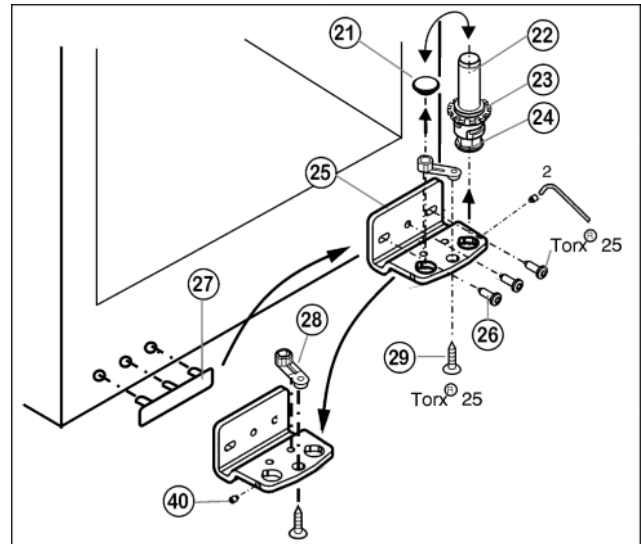

Fig. 6

- ▶ Using the accompanying Allen key, unscrew the threaded pin Fig. 6 (40) by about 1 turn.
- ▶ Turn and lift out the bearing pin Fig. 6 (22) together with the washer Fig. 6 (23) and adjustable-height foot Fig. 6 (24).
- ▶ Lift out the stopper Fig. 6 (21).
- ▶ Unscrew Fig. 6 (26) the turn hinge Fig. 6 (25).
- ▶ Fully unscrew the threaded pin Fig. 6 (40) and screw it in on the opposite side, at the turn hinge, until it is flush outside with the turn hinge.
- ▶ Unscrew Fig. 6 (29) the bearing element Fig. 6 (28) transfer it to the opposite location hole of the turn hinge and screw it firmly into place.
- ▶ Re-insert the stopper Fig. 6 (21) into the other hole.
- ▶ Carefully lift off the cover on the handle side Fig. 6 (27) and transfer it to the opposite side.
- ▶ Screw the turn hinge Fig. 6 (25) firmly into place on the new hinge side, possibly using a cordless screwdriver (with 4 Nm).
- ▶ Re-insert the bearing pin Fig. 6 (22) together with the washer and adjustable-height foot.
- ▶ Tighten the threaded pin Fig. 6 (40).

4.3.5 Transferring the handle

- ▶ Transfer the spring clamp Fig. 7 (31): Depress the latch nose and pull the spring clamp off over it.
- ▶ Slide the spring clamp into place on the new hinge side until it clicks into place.

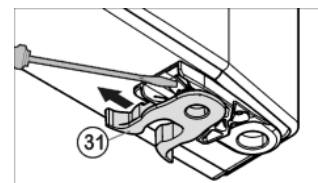

Fig. 7

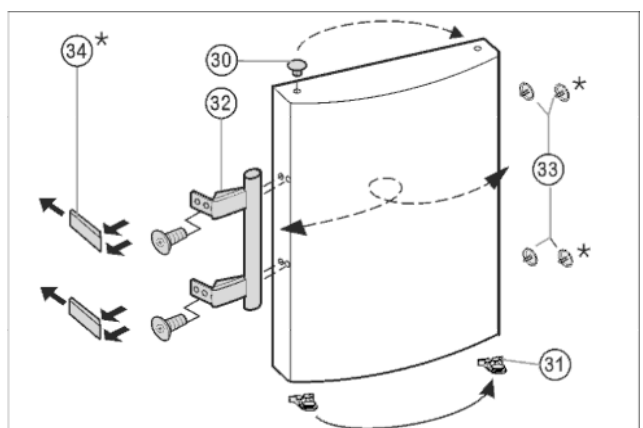

Fig. 8

Putting into operation

- ▶ Lift the stopper *Fig. 8 (33)* out of the door bearing bush and transfer it.
- ▶ Dismantle the door handle *Fig. 8 (32)*, stoppers *Fig. 8 (33)* and pressure plates* *Fig. 8 (34)* and transfer to the opposite side.
- ▶ When fitting the pressure plates on the opposite side, make sure they snap properly into place.*

4.3.6 Fitting the door

- ▶ Place the door from above onto the lower bearing pin *Fig. 6 (22)*.
- ▶ Close the door.
- ▶ Insert the upper turn hinge *Fig. 4 (12)* in the door on the new hinge side.
- ▶ Screw the upper turn hinge *Fig. 4 (12)* firmly into place (with **4 Nm**)(2x Torx® 25) *Fig. 4 (13)*. Possibly make preliminary holes with a bradawl or use a cordless screwdriver.
- ▶ Snap the cover *Fig. 4 (10)* and cover *Fig. 4 (11)* into place at the opposite side.

4.3.7 Aligning the door

- ▶ Align the door to the appliance housing by way of the two oblong holes in the bottom turn hinge *Fig. 6 (25)*. To do so, unscrew the middle screw.



WARNING

Risk of injury due to the door dropping out!
If the bearing parts are not screwed into place firmly enough, the door may drop out. This may lead to severe injuries. What is more, the door may not close and therefore the appliance may fail to cool properly.

- ▶ Screw the turn hinges firmly into place with 4 Nm.
- ▶ Check all of the screws and retighten if necessary.

4.4 Insertion into a row of kitchen units

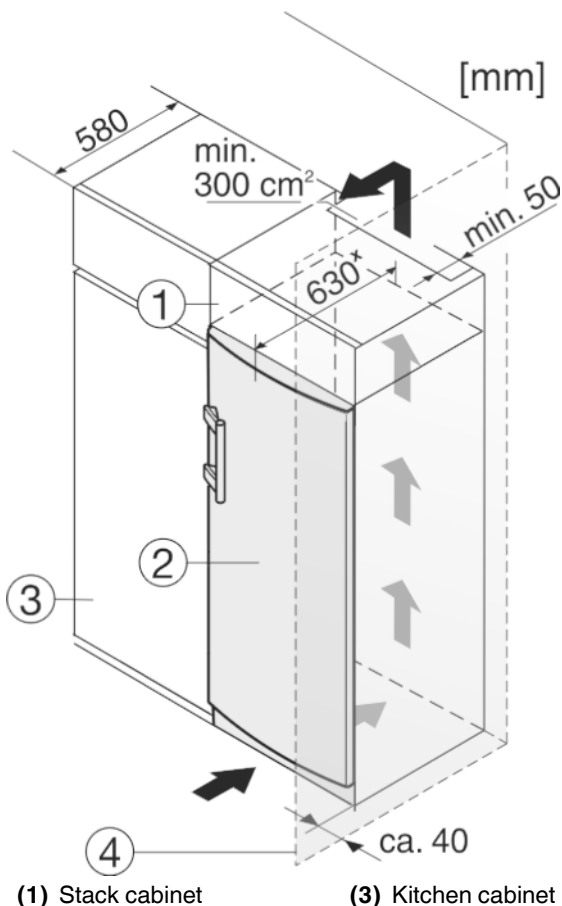

Fig. 9

(2) Appliance

(4) Wall

* For appliances supplied with wall spacers, the measurement increases by 35 mm (see 4.2).

The appliance can be built into kitchen units. A top cupboard *Fig. 9 (2)* can be added above the appliance in order to bring the appliance *Fig. 9 (1)* up to the height of the fitted kitchen units.

When installing with kitchen units (max. depth 580 mm), the appliance can be positioned directly next to the kitchen cabinet *Fig. 9 (3)*. The appliance will project by 34 mm* at the sides and 50 mm* in the centre of the appliance in relation to the kitchen cabinet front.

Ventilation requirements:

- At the back of the stack cabinet there has to be a ventilation duct of at least 50 mm depth throughout the width of the stack cabinet.
- The cross section of the ventilation gap below the ceiling must be at least 300 cm².
- the larger the ventilation space, the more energy-saving the appliance is in operation.

If the appliance is installed with the hinges next to a wall *Fig. 9 (4)*, the distance between appliance and wall has to be at least 40 mm. This corresponds to the projection of the handle when the door is open.

4.5 Disposing of packaging



WARNING

Danger of suffocation due to packing material and plastic film!

- ▶ Do not allow children to play with packing material.

The packaging is made of recyclable materials:

- corrugated board/cardboard
- expanded polystyrene parts
- polythene bags and sheets
- polypropylene straps
- nailed wooden frame with polyethylene panel*

- ▶ Take the packaging material to an official collecting point.



4.6 Connecting the appliance

NOTICE

Failure to connect properly

Damage to the electronics.

- ▶ Do not use a standalone inverter.
- ▶ Do not use an energy saving plug.



WARNING

Failure to connect properly

Fire hazard.

- ▶ Do not use an extension cable.
- ▶ Do not use distributor blocks.

The type of current (alternating current) and voltage at the installation site have to conform with the data on the type plate (see Appliance at a glance).

The socket must be properly earthed and fused. The tripping current for the fuse must be between 10 A and 16 A.

The socket must be easily accessible so that the appliance can be quickly disconnected from the supply in an emergency. It must be outside the area of the rear of the appliance.

- ▶ Check the electrical connection.
- ▶ Plug in the power plug.



4.7 Switching on the appliance

- ▶ Press On/Off button *Fig. 3 (3)*.
- ▷ The temperature display indicates the current temperature.
- ▷ The interior light is on when the door is open.
- ▷ If "DEMO" is displayed, demo mode is activated. Please contact the after sales service.

5 Control

5.1 Brightness of the temperature display

You can adjust the brightness of the temperature display to the light conditions of the room in which the appliance is installed.

5.1.1 Adjusting the brightness

The brightness is adjustable between **h0** (no illumination) and **h5** (maximum luminosity).

- ▶ To activate the setting mode: press SuperCool button *Fig. 3 (2)* for about 5s.
- ▷ The display indicates **c**.
- ▷ The menu symbol *Fig. 3 (5)* shines.
- ▶ Using the Up setting button *Fig. 3 (7)* and Down setting button *Fig. 3 (6)*, select **h**.
- ▶ To confirm: briefly press the SuperCool button *Fig. 3 (2)*.
- ▶ To set the display brighter: press the Up setting button *Fig. 3 (7)*.
- ▶ To set the display darker: press the Down setting button *Fig. 3 (6)*.
- ▶ To confirm: briefly press the SuperCool button *Fig. 3 (2)*.
- ▷ The brightness is adjusted to the new value.
- ▶ To deactivate the setting mode: press the On/Off button *Fig. 3 (3)*.

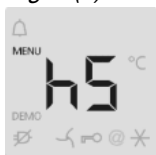

- or-
- ▶ Wait for 5 minutes.

- ▷ The temperature is indicated again in the temperature display.

5.2 Child proofing

The child-proofing function enables you to make sure that the appliance is not inadvertently switched off by playing children.



5.2.1 Setting the child lock function

- ▶ To activate the setting mode: press SuperCool button *Fig. 3 (2)* for about 5 s.
- ▷ The display indicates **c**.
- ▷ The menu symbol *Fig. 3 (5)* shines.
- ▶ Briefly press the SuperCool button *Fig. 3 (2)* to confirm. When **cl** is indicated in the display:
- ▶ to activate the child lock, briefly press the SuperCool button *Fig. 3 (2)*.



- ▷ The child lock symbol *Fig. 3 (11)* shines. **c** flashes in the display. When **cl** is indicated in the display:
- ▶ to deactivate the child lock, briefly press the SuperCool button *Fig. 3 (2)*.
- ▷ The child lock symbol *Fig. 3 (11)* goes out. **c** flashes in the display.

- ▶ To deactivate the set-up mode: press On/Off button *Fig. 3 (3)*.

-or-

- ▶ Wait for 5 minutes.
- ▷ The temperature is indicated again in the temperature display.

5.3 Door alarm*

An audible warning sounds if the door is open for longer than 60 seconds.

The audible warning stops automatically when the door is closed.



5.3.1 Muting the door alarm*

The audible alarm can be muted when the door is open. The sound switch-off function is active as long as the door is left open.

- ▶ Press alarm button *Fig. 3 (1)*.
- ▷ The door alarm is silenced.

5.4 Food refrigeration

Note

The energy consumption increases and the cooling performance decreases if the ventilation is inadequate.

- ▶ Always keep the air slits of the fan free.

- ▶ Store perishable food such as ready-to-serve dishes, meat products and sausages in the coldest zone. Place butter and preserves in the upper area and in the door (see Appliance at a glance).
- ▶ Use recyclable plastic, metal, aluminium and glass containers and cling film for wrapping.
- ▶ Use the front area of the refrigerator compartment floor only for briefly putting down cooled products, e.g. when rearranging and sorting. However do not leave cooled products there otherwise they may be pushed back or tipped over when the door is closed.
- ▶ Do not store food too close together to enable good air circulation.
- ▶ To safeguard bottles from tipping over: move the bottle holder.

5.5 Setting the temperature

The temperature depends on the following factors:

- the frequency of opening the door
- the room temperature of the installation location
- the type, temperature and quantity of the food

The temperature can be set from 9 °C to 2 °C, the recommended temperature is 5 °C.

- ▶ For a higher temperature setting: press Up button *Fig. 3 (7)*.
- ▶ For a lower temperature setting: press Down button *Fig. 3 (6)*.
- ▷ When the button is pressed the first time, the previously set value is indicated, flashing, in the temperature display.
- ▶ To change the temperature in 1 °C steps: briefly press the button.
- ▶ To change the temperature continuously: hold down the button.
- ▷ The value is displayed flashing during the setting operation.
- ▷ The actual temperature is displayed about 5 s after the last press of a button. The temperature slowly adjusts to the new value.

Control

5.6 SuperCool

With SuperCool you switch to the highest cooling performance to reach lower cooling temperatures. Use SuperCool, to rapidly cool large amounts of food.



When SuperCool is activated, the fan* may run. The appliance operates with maximum cooling performance, which means that the noise of the refrigeration unit may be temporarily louder.

The SuperCool function uses slightly more energy.

5.6.1 Cooling with SuperCool

- ▶ Briefly press SuperCool button *Fig. 3 (2)*.
- ▷ The SuperCool symbol *Fig. 3 (12)* lights up in the display.
- ▷ The cooling temperature drops to the coldest value. SuperCool is activated.
- ▷ SuperCool is automatically deactivated after 6 to 12 hours. The appliance continues to operate in the energy-saving, normal mode.

5.6.2 To prematurely deactivate SuperCool

- ▶ Briefly press SuperCool button *Fig. 3 (2)*.
- ▷ The SuperCool symbol *Fig. 3 (12)* goes out in the display.
- ▷ SuperCool is deactivated.

5.7 Fan

With the fan you can rapidly cool large quantities of fresh food or achieve a relatively even distribution of temperature across all the storage levels.



The forced-air cooling is to be recommended:

- at high room temperature (above 33 °C)
- at high humidity

The forced-air cooling uses slightly more energy. To save energy, the fan switches off automatically when the door is open.

5.7.1 Switching on the fan

- ▶ Briefly press the fan button *Fig. 3 (8)*.
- ▷ The fan symbol *Fig. 3 (10)* shines.
- ▷ The fan is active. In some appliances, the fan is only activated when the compressor is running.

5.7.2 To switch off the fan

- ▶ Briefly press the fan button *Fig. 3 (8)*.
- ▷ The fan symbol *Fig. 3 (10)* goes out.
- ▷ The fan is switched off.

5.8 Shelves

5.8.1 Moving or removing shelves

The shelves have stops preventing them from being unintentionally pulled out.

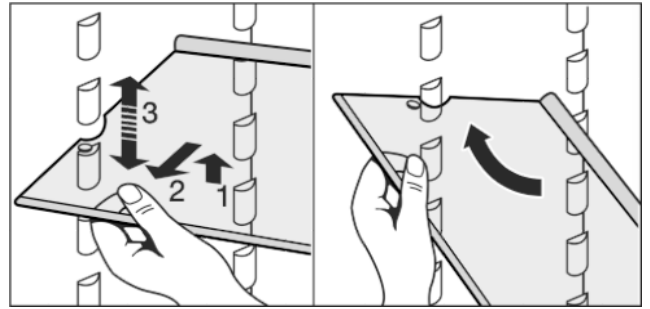
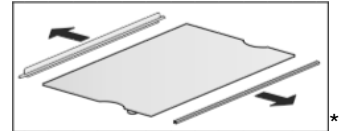

*Fig. 10**

- ▶ Lift the shelf slightly and pull forward a little.
- ▶ Adjust the height of the shelf. To do so, push the cut-outs along the supports.*
- ▶ In order to remove the shelf fully, place it at a slant and pull out towards the front.*
- ▶ Insert shelf with the raised edge pointing upwards at the back.*
- ▷ The food does not freeze onto the rear wall.

5.8.2 Dismantling shelves

- ▶ The shelves can be dismantled for cleaning.



5.9 Using the sectioned shelf

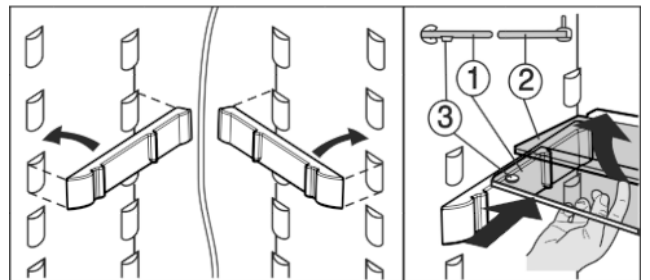

Fig. 11

- ▶ The glass shelf with stop face (2) has to be at the back.

5.10 Door racks

5.10.1 Moving the storage rack

- ▶ Remove storage rack according to illustration.

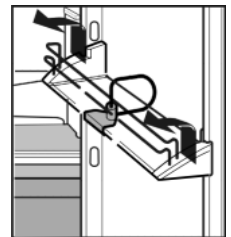

The boxes can be removed and placed on the table as a single unit.

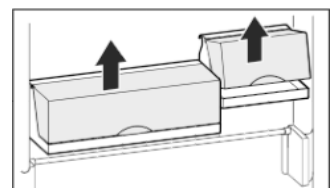

Three small boxes are available through the customer service as optional equipment instead of one wide and one small box.

Either one or both the boxes can be used. If particularly tall bottles are to be stored, hang only a single box above the bottle rack.

- ▶ Re-positioning the boxes: Lift them for removal and re-position them as required.

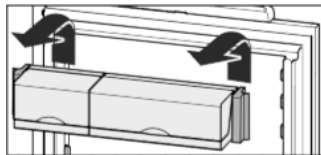

- ▷ In the case of the bottom drawer, the drawer locking device additionally engages and the vegetable drawer sits firmly on the telescopic slides.

6 Maintenance

6.1 Cleaning the appliance



WARNING

- Risk of injury and damage as a result of hot steam!
- Hot steam can lead to burns and can damage the surfaces.
- ▶ Do not use any steam cleaners!

NOTICE

- Incorrect cleaning damages the appliance!
- ▶ Do not use cleaning agents in concentrated form.
- ▶ Do not use any scouring or abrasive sponges or steel wool.
- ▶ Do not use any sharp or abrasive cleaning agents, nor any that contain sand, chloride or acid.
- ▶ Do not use chemical solvents.
- ▶ Do not damage or remove the type plate on the inside of the appliance. It is important for the customer service.
- ▶ Do not pull off, bend or damage cables or other components.
- ▶ Do not allow any cleaning water to enter the drain channel, ventilation grille or electrical parts.
- ▶ Please use soft cleaning cloths and a universal pH-neutral cleaning agent.
- ▶ Please use cleaning and care products suitable for contact with foodstuffs in the appliance interior.

- ▶ **Empty appliance.**
- ▶ **Pull out the power plug.**



- ▶ Clean **plastic outer and inner surfaces** with lukewarm water and a little washing-up liquid.

Do not apply stainless steel cleaning agent to glass or plastic surfaces to prevent them from being scratched. Darker areas at the beginning and quite an intensive colour of the stainless steel surface are normal.*

NOTICE*

The stainless steel doors are treated with a high quality surface coating and must not be treated with stainless steel care products.



Otherwise the surface coating will be affected.

- ▶ **Coated door surfaces** and **painted side walls** must only be wiped with a soft, clean cloth. If they are very dirty, use a little water or a neutral cleaner. A microfibre cloth may also be used.
- ▶ If the **stainless steel side walls** are dirty, clean them using a commercially available stainless steel cleaning agent. Then evenly apply the accompanying stainless steel care product, making strokes in the direction of the grain.

- ▶ Clean **drain hole**: Remove deposits with a narrow instrument, e.g. a cotton bud.

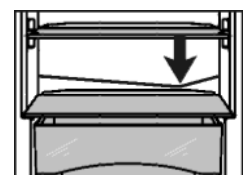

- ▶ Most of the **parts** can be dismantled for cleaning: see the relevant chapter.
- ▶ Clean **items of equipment** by hand with lukewarm water and a little washing-up liquid.

5.10.2 Dismantling door racks

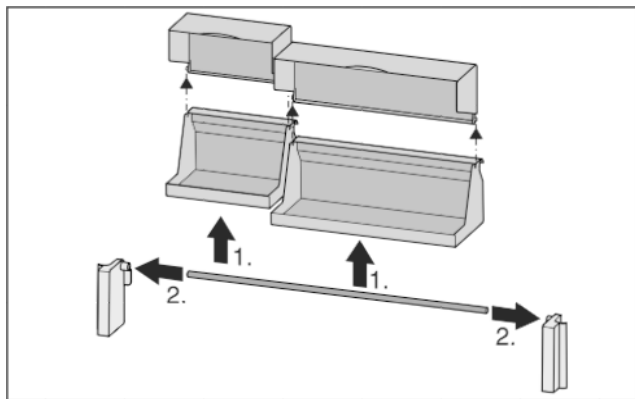
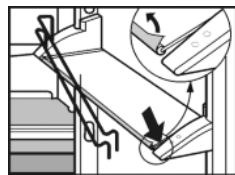

Fig. 12



- ▶ The door racks can be dismantled for cleaning.

5.11 Removing the bottle holder

- ▶ Always take hold of the bottle holder on the plastic part.

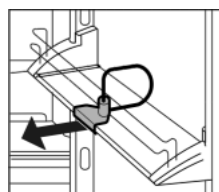

5.12 Vegetable bins

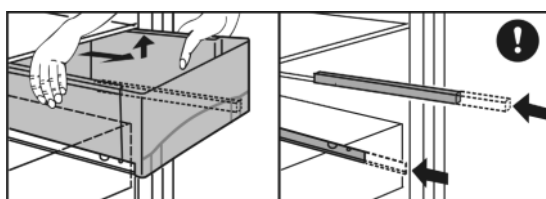

Fig. 13

To remove the vegetable bins:

- ▶ pull the vegetable bin all the way out and tilt it forwards a little.
- ▷ In the case of the bottom drawer, the drawer locking device is additionally released and the vegetable bin can be removed.
- ▶ Push the projecting telescopic slides back in.

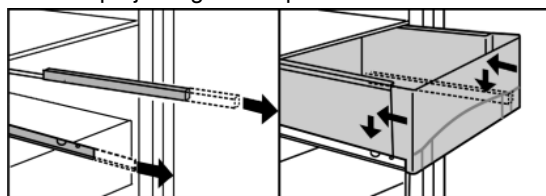

Fig. 14

To insert the vegetable bins:

- ▶ place the vegetable bin on the telescopic slides and push to the rear, exerting slight pressure.

Malfunctions

- ▶ Only use a damp cloth to clean the **telescopic rails**. The grease in the runners is for lubrication purposes and must not be removed.

After cleaning:

- ▶ Wipe dry the appliance and items of equipment.
- ▶ Connect the appliance and switch it on again.
- ▶ Put the food back inside.

6.2 Customer service

First check whether you can correct the fault yourself by reference to the list (see Malfunction). If this is not the case, please contact the customer service whose address is given in the enclosed customer service list.



WARNING

Risk of injury if repair work is not carried out professionally!

- ▶ Have any repairs and action - not expressly specified - on the appliance and mains cable carried out by service personnel only. (see Maintenance)

- ▶ Read the appliance designation *Fig. 15 (1)*, service No. *Fig. 15 (2)* and serial No. *Fig. 15 (3)* off the type plate located inside the appliance on the left-hand side.

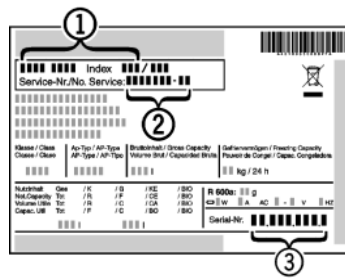

Fig. 15

- ▶ Notify the customer service, specifying the fault, appliance designation *Fig. 15 (1)*, service No. *Fig. 15 (2)* and serial No. *Fig. 15 (3)*.
- ▷ This will help us to provide you with a faster and more accurate service.
- ▶ Keep the appliance closed until the customer service arrives.
- ▷ The food will stay cool longer.
- ▶ Pull out the mains plug (not by pulling the connecting cable) or switch off the fuse.

7 Malfunctions

Your appliance is designed and manufactured for a long life span and reliable operation. If a malfunction nonetheless occurs during operation, check whether it is due to a handling error. In this case you will have to be charged for the costs incurred, even during the warranty period. You may be able to rectify the following faults yourself:

Appliance does not work.

- The appliance is not switched on.
- ▶ Switch on the appliance.
- The power plug is not properly inserted in the wall socket.
- ▶ Check power plug.
- The fuse of the wall socket is not in order.
- ▶ Check fuse.

The compressor runs for a long time.

- The compressor switches to a low speed when little cold is needed. Although the running time is increased as a result, energy is saved.
- ▶ This is normal in energy-saving models.
- SuperCool is activated.
- ▶ The compressor runs for longer in order to rapidly cool the food. This is normal.

A LED on the bottom rear of the appliance (at the compressor) flashes regularly every 15 seconds*.

- The inverter is equipped with a diagnostic LED.
- ▶ The flashing is normal.

Excessive noise.

- Due to the various speed steps, speed-regulated* compressors can generate different running noises.
- ▶ The sound is normal.

A bubbling and gurgling noise.

- This noise comes from the refrigerant flowing in the refrigeration circuit.
- ▶ The sound is normal.

A quiet clicking noise.

- The noise is produced whenever the refrigeration unit (motor) automatically switches on or off.
- ▶ The sound is normal.

A hum. It is briefly a little louder when the refrigeration unit (the motor) switches on.

- The refrigeration increases automatically when the SuperCool function is activated, fresh food has just been placed in the appliance or the door has been left open for a while.
- ▶ The sound is normal.
- The ambient temperature is too high.
- ▶ Solution: (see 1.2)

A low hum.

- The sound is produced by air flow noise of the fan.
- ▶ The sound is normal.

Vibratory noise.

- The appliance is not fixed to the ground. The running of the cooling unit therefore makes objects and adjacent furniture vibrate.
- ▶ Adjust appliance via the height-adjustable feet.
- ▶ Move bottles and containers apart.

The temperature display indicates: F0 to F9

- There is a fault.
- ▶ Please contact the after-sales service (see Maintenance).

DEMO shines in the temperature display.

- The demo mode is activated.
- ▶ Please contact the after-sales service (see Maintenance).

The outer surfaces of the appliance are warm*.

- The heat of the refrigeration circuit is used to prevent condensate from forming.
- ▶ This is normal.

The temperature is not cold enough.

- The door of the appliance is not properly closed.
- ▶ Close the door of the appliance.
- Insufficient ventilation.
- ▶ Keep ventilation grille clear, and clean it.
- The ambient temperature is too high.
- ▶ Solution: (see 1.2) .
- The appliance was opened too frequently or for too long.
- ▶ Wait to see whether the appliance reaches the required temperature by itself. If not, please contact the after sales service (see Maintenance).
- The temperature is incorrectly set.
- ▶ Set the temperature to a colder setting and check after 24 hours.
- The appliance is too close to a source of heat (stove, heater etc).
- ▶ Change the position of the appliance or the source of heat.

The internal light does not come on.

- The appliance is not switched on.
- ▶ Switch on the appliance.
- The door was open longer than 15 min.

- ▶ The interior light automatically switches off if the door has been open for about 15 min.
- The LED illumination is defective or the cover is damaged:

**WARNING**

Risk of injury due to electric shock!
Live parts are located under the cover.

- ▶ Have the LED interior light changed or repaired only by the customer service or by specialized personnel trained for the purpose.

**WARNING**

Danger of injury by LED lamp!
The light intensity of the LED illumination corresponds to laser class 1/1M.

If the cover is defective:

- ▶ Do not look into the illumination with optical lenses from the immediate proximity. This can cause injury to the eyes.

8 Decommissioning

8.1 Switching off the appliance

- ▶ Press On/Off button *Fig. 3 (3)* for approx. 2 seconds.
- ▷ The temperature display is dark.
- ▷ If the appliance cannot be switched off, the child lock function is active (see 5.2) .

8.2 Taking the appliance out of service

- ▶ Empty the appliance.
- ▶ Switch off the appliance (see Decommissioning).
- ▶ Remove mains connector.
- ▶ Clean the appliance (see 6.1) .



- ▶ Leave the door open to prevent odour.

9 Disposing of the appliance

The appliance contains some reusable materials and should be disposed of properly - not simply with unsorted household refuse. Appliances which are no longer needed must be disposed of in a professional and appropriate way, in accordance with the current local regulations and laws.



When disposing of the appliance, ensure that the refrigeration circuit is not damaged to prevent uncontrolled escape of the refrigerant it contains (data on type plate) and oil.

- ▶ Disable the appliance.
- ▶ Pull out the plug.
- ▶ Cut through the connecting cable.



Liebherr-Hausgeräte Ochsenhausen GmbH

Memminger Straße 77-79

88416 Ochsenhausen

Deutschland

home.liebherr.com