



User Guide

Quality, Design and Innovation



home.liebherr.com/fridge-manuals









LIEBHERR

Contents

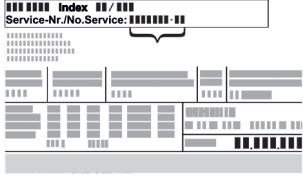
1	Appliance at a glance.....	3
1.1	Scope of supply.....	3
1.2	Overview of appliances and equipment.....	3
1.3	Special features.....	4
1.4	Range of use of appliance.....	4
1.5	Appliance noise emissions.....	4
1.6	Conformity.....	4
1.7	SVHC substances according to REACH regulation.....	5
2	General safety instructions.....	5
3	Functionality of the Touch & Swipe display.....	6
3.1	Navigation and symbol explanation.....	6
3.2	Menus.....	7
3.3	Sleep mode.....	8
4	Putting into operation.....	8
4.1	Installation conditions.....	8
4.2	Appliance dimensions.....	8
4.3	Transporting appliance.....	9
4.4	Unpacking appliance.....	9
4.5	Connect power cable.....	9
4.6	Mounting the anti-tipping device.....	9
4.7	Installing appliance.....	10
4.8	Installing multiple appliances.....	10
4.9	After installation.....	10
4.10	Disposing of packaging.....	10
4.11	Reversing the door opening direction.....	10
4.12	Aligning the door.....	15
4.13	Connecting appliance.....	16
4.14	Switching on appliance (first use).....	16
4.15	Using equipment.....	17
4.16	Centre grid shelf.....	17
5	Storage.....	17
5.1	Information regarding storage.....	17
6	Controls.....	18
6.1	Control and display elements.....	18
6.1.1	Status display.....	18
6.1.2	Display symbols.....	18
6.1.3	Acoustic signals.....	19
6.2	Appliance functions.....	19
6.2.1	Notes on the appliance functions.....	19
6.2.2	Switching appliance on and off.....	19
6.2.3	Temperature.....	20
6.2.4	Temperature recording.....	20
6.2.5	Lighting.....	20
6.2.6	Door lock.....	21
6.2.7	SmartLock.....	22
6.2.8	Settings menu access protection.....	23
6.2.9	Access codes.....	24
6.2.10	Remote control.....	26
6.2.11	Maintenance interval reminder.....	27
6.2.12	Language.....	27
6.2.13	Date and time.....	27
6.2.14	Temperature unit.....	28
6.2.15	Display brightness.....	28
6.2.16	Alarm Sound.....	28
6.2.17	Key Sound.....	29
6.2.18	WiFi connection.....	29
6.2.19	LAN connection.....	30
6.2.20	Device information.....	31
6.2.21	Operating hours.....	31
6.2.22	Software.....	31
6.2.23	Defrosting.....	32
6.2.24	Data download / Datalogging.....	32
6.2.25	Sensor calibration.....	33
6.2.26	Temperature alarm.....	33
6.2.27	Door alarm.....	34
6.2.28	Light alarm.....	35
6.2.29	Alarm simulation.....	35
6.2.30	Alarm log.....	36
6.2.31	Alarm relay.....	36
6.2.32	Demo mode.....	37
6.2.33	Resetting to factory settings.....	37
6.3	Message.....	38
6.3.1	Warnings.....	38
6.3.2	Reminders.....	40
7	Features.....	40
7.1	Safety lock.....	40
7.2	Remote control.....	41
7.3	Sensors.....	41
7.4	Sensor info.....	41
7.5	Interfaces.....	42
8	Maintenance.....	43
8.1	Maintenance schedule.....	43
8.2	Defrosting appliance.....	44
8.3	Cleaning the appliance.....	44
8.4	Replacing appliance battery.....	45
8.5	Replacing the remote control batteries.....	45
9	Customer help.....	45
9.1	Technical specifications.....	45
9.2	Technical fault.....	46
9.3	Customer Service.....	47
9.4	Type plate.....	47
10	Shutting down.....	47
11	Disposal.....	47
11.1	Preparing appliance for disposal.....	47
11.2	Disposing of the appliance in an environmentally friendly manner.....	47
12	Additional information.....	48
13	Quick Start Guide for everyday use.....	49

The manufacturer is continually working on the further development of all types and models. Please be aware that we reserve the right to make changes to the shape, equipment and technology.

Symbol	Explanation
	<p>Read instructions</p> <p>Please read the information in these instructions carefully to understand all of the benefits of your new appliance.</p>
	<p>Additional information on the Internet</p> <p>The digital manual with additional information and in other languages can be found via the QR code on the front of the manual or by entering the service number at home.liebherr.com/fridge-manuals.</p> <p>The service number can be found on the serial tag:</p>  <p style="text-align: right;"><i>Fig. Example illustration</i></p>
	<p>Check appliance</p> <p>Check all parts for transport damage. If you have any complaints, please contact your agent or customer service.</p>

Symbol	Explanation
	Differences These instructions apply to a range of models, so differences are possible. Sections that apply to certain models only are marked with an asterisk (*).
	Instructions and results Instructions are marked with a ▶. Results are marked with a ▷.
	Videos Videos about the appliances are available on the YouTube channels of Liebherr-Hausgeräte.

These operating instructions apply to:

- SFPvh 1402
- SFPvh 6501
- SFPvh 8401

1 Appliance at a glance

1.1 Scope of supply

Check all parts for transport damage. If you have any complaints, please contact your dealer or Customer Service. (see 9.3 Customer Service)

The delivery comprises the following parts:

- Free-standing appliance
- Equipment *
- Installation materials *
- Operating instructions
- Service brochure
- Quality certificate *
- Mains cable
- Remote control
- Emergency unlocking key
- Wall fastening kit

1.2 Overview of appliances and equipment

SFPvh 6501
SFPvh 8401

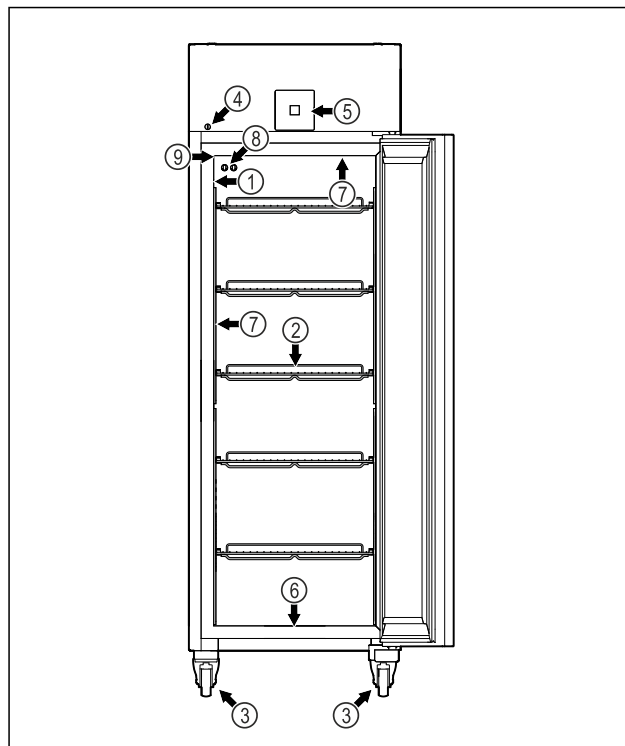

Fig. 1 Example illustration

- | | |
|--|--------------------------------------|
| (1) Type plate | (6) Drain opening for cleaning water |
| (2) Grid shelves | (7) Interior lighting * |
| (3) Castors | (8) P sensor |
| (4) Lock | (9) Sensor feedthrough |
| (5) Control elements and temperature display | |

SFPvh 1402

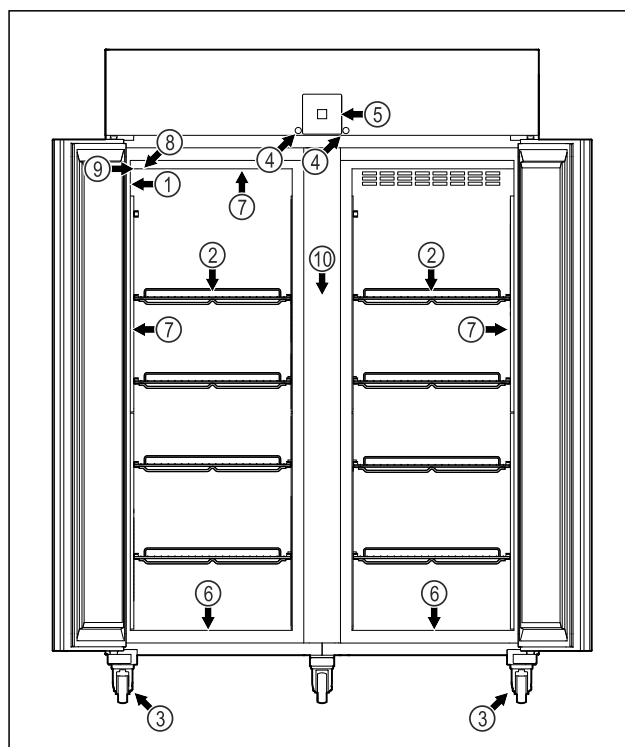

Fig. 2 Example illustration

- | | |
|------------------|--------------------------------------|
| (1) Type plate | (6) Drain opening for cleaning water |
| (2) Grid shelves | (7) Interior lighting * |
| (3) Castors | (8) P sensor |
| (4) Lock | (9) Sensor feedthrough |

Appliance at a glance

(5) Control elements and temperature display

(10) Intermediate grate

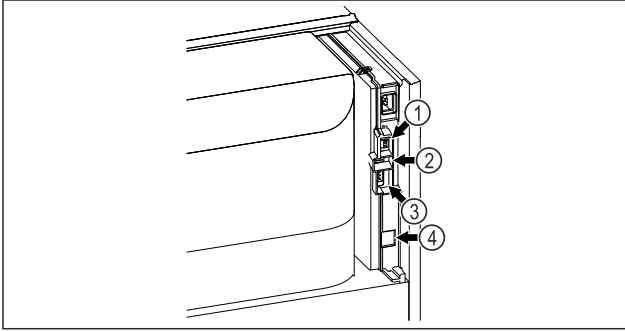

Fig. 3 Example illustration

(1) Connection for P sensor

(2) USB interface

(3) Potential-free alarm output

(4) LAN interface

1.3 Special features

Note

Accessories are available from Customer Service (see 9.3 Customer Service) and the Liebherr-Hausgeräte store at home.liebherr.com/shop/de/deu/zubehor.html.

SmartModule

The appliance is fitted with a SmartModule. This is a WiFi and LAN interface for the connection between the appliance and an external documentation and alarm system such as Liebherr SmartMonitoring.

Liebherr SmartMonitoring Dashboard is not available in all countries. Check availability via the QR code (see 6.2.18 WiFi connection) by entering your model.

Retrofitting drawers

Temperature qualification is required when retrofitting drawer systems in Liebherr refrigerators/freezers where these are used for temperature-sensitive materials such as chilled drugs and refrigerated products which are subject to specific standards requirements. Retrofitting drawers in Liebherr refrigerators/freezers can result in the goods stored becoming spoiled or damaged. The retrofitting must therefore be completed exclusively by authorised service providers from the manufacturer of the refrigerator/freezer.

1.4 Range of use of appliance

Intended use

This laboratory freezer is suitable for the professional storage of products at temperatures between -9 °C and -35 °C.

Typical products to be stored include research samples, reagents, laboratory inventory etc.

The appliance meets the requirements of DIN 13277 Refrigerators and freezers for laboratory and medical applications.

The storage of temperature-sensitive substances requires the use of an independent, continuous monitoring alarm system. This alarm system must be designed

in such a way that a responsible person can register any alarm status so that appropriate action can be taken.

Foreseeable incorrect use

Do not use the appliance for the following applications:

- Storage and refrigeration of:
 - Chemically unstable, flammable or corrosive substances
 - Blood, plasma or other body fluids for the purpose of infusion, application or introduction in the human body.
- Use in potentially explosive atmospheres.
- Use outdoors or in areas exposed to dampness and splashing water.
- Use in residential areas because adequate protection of radio reception cannot be ensured in such environments.*

Improper use of the appliances will result in goods stored being damaged or spoiled.

Climate classes

The applicable climate class for your appliance is printed on the type plate.

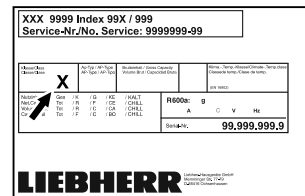

Fig. 4 Type plate

(X) This climate class indicates the ambient conditions in which the appliance can be safely operated.

Climate class (X)	max. room temperature	max. rel. humidity
7	35 °C	75%

Note

The minimum permitted room temperature at the setup location is 10 °C.

Under borderline conditions, slight condensation may form on the glass door (depending on the equipment) and on the side walls.

1.5 Appliance noise emissions

The A-weighted emission sound pressure level during operation of the appliance is under 70 dB(A) (sound power rel. 1 pW).

1.6 Conformity

The coolant circuit has been tested for leak-tightness. The appliance complies with the relevant safety regulations.

EU Declaration of Conformity	
Manufacturer/Exhibitor:	LIEBHERR-HAUSGERÄTE LIENZ GMBH
Address:	A-9900 Lienz, Dr. Hans Liebherr Straße 1
The designated product complies with the provisions of the following European directives and regulations: (EU) 2019/2020, 2014/35/EU, 2014/30/EU, 2011/65/EU	
The built-in radio module complies with Directive 2014/53/EU. Information on the radio module (see 9.1 Technical specifications).	
The full text of the EU Declaration of Conformity is available at the following web address: www.liebherr.de	

1.7 SVHC substances according to REACH regulation

You can check whether your appliance contains SVHC substances according to REACH regulation at the following link: home.liebherr.com/de/deu/de/liebherr-erleben/nachhaltigkeit/umwelt/scip/scip.html

2 General safety instructions

Please keep these operating instructions in a safe place so you can refer back to them at any time.

If you pass the appliance on, please hand these operating instructions to the next user.

Read these operating instructions carefully before use to ensure safe and correct use of the appliance. Follow the instructions, safety instructions and warning messages included at all times. They are important for ensuring you can operate and install the appliance safely and without any problems.

Danger for the user:

- This appliance may only be used by specialist and laboratory personnel who have been trained for this purpose and are familiar with all safety measures pertaining to laboratory work. Children and persons with reduced physical, sensory or mental capabilities or lack of experience and knowledge must not commission or operate this appliance.
- The socket must be easily accessible so that the appliance can be disconnected quickly from the electricity supply in an emergency. It must not be located in the area behind the appliance.
- When disconnecting the appliance from the supply, always take hold of the plug. Do not pull the cable.
- In the event of a fault pull out the mains plug or deactivate the fuse.

- **WARNING:** Do not damage the mains power cable. Do not operate the appliance with a defective mains power cable.
- **WARNING:** Multiple sockets/distributors and other electronic equipment (such as halogen transformers) must not be placed or operated at the rear of the appliance.
- **WARNING:** Keep ventilation openings, in the appliance enclosure or in the built-in structure, clear of obstruction.
- Only customer service or other specially trained staff may repair or perform other operations on the appliance.
- Only assemble, connect and dispose of the appliance according to the instructions.

Fire hazard

- The coolant used (information on the model plate) is ecofriendly but also flammable. Any leaking coolant may ignite.
 - **WARNING:** Do not damage refrigeration circuit.
 - Do not handle ignition sources inside the appliance.
 - **WARNING:** Do not use electrical appliances in the fridge compartment which do not comply with the design recommended by the manufacturer.
 - If the refrigerant leaks: remove any naked flames or ignition sources from the vicinity of the leakage point. Properly air the room. Inform customer services.
- Do not operate the appliance close to explosive gases.
- Do not store or use petrol or other flammable gases and liquids close to the appliance.
- Do not store any explosive substances, such as aerosol containers with flammable propellant gas, in the appliance. To identify these spray cans, look for the list of contents printed on the can, or a flame symbol. Gases possibly escaping may ignite due to electrical components.
- Keep burning candles, lamps and other items with naked flames away from the appliance so that they do not set the appliance on fire.
- Alcoholic liquids or other containers with alcohol inside must only be stored tightly sealed. Any alcohol that leaks out may be ignited by electrical components.

Functionality of the Touch & Swipe display

Danger of tipping and falling:

- **WARNING:** In order to prevent danger due to an unstable appliance, it must be fixed in accordance with the instructions.
- Do not misuse the plinth, drawers, doors etc. as a step or for support.

Danger of frostbite, numbness and pain:

- Avoid prolonged skin contact with cold surfaces or refrigerated/frozen goods or take protective measures, e.g. wear gloves.

Danger of injury and damage:

- **WARNING:** Do not use mechanical equipment or other methods to speed up the defrosting process other than those recommended by the manufacturer.
- **WARNING:** Risk of injury due to electric shock! There are live electrical parts under the cover.
Only have the LED interior lighting replaced or repaired by customer service or other suitably trained professionals.
- **NOTICE:** Appliance must only be used using original manufacturer accessories or using accessories from other providers approved by the manufacturer. The user bears the risk of using accessories which are not approved.

Risk of crushing

- Do not hold the hinge when opening and closing the door. Fingers may get caught.

Specialist personnel qualifications:

The appliance may only be installed, tested, maintained, and commissioned by specialist personnel who are familiar with the installation, commissioning, and operation of the appliance.

Specialist personnel are persons who, on account of their specialist training, knowledge and experience as well as their knowledge of the relevant standards, are able to assess and perform the work assigned to them and identify potential hazards. They must have training, instruction, and authorisation to work on the appliance.

Symbols on the appliance:



This symbol may be located on the compressor. It relates to the oil in the compressor and makes reference to the risk that: **Swallowing or inhaling can be fatal.** This advice is only relevant to recycling. There is no danger in normal operation.



WARNING: Danger of fire / flammable materials. This symbol is located on the compressor and indicates the danger of flammable materials. Do not remove the sticker.

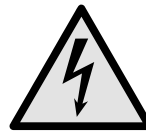

The symbol is located on the back of the appliance near the alarm relay and indicates the following danger: **Electric shock!** Even if an appliance is disconnected from the mains there may still be extraneous voltage. Do not remove sticker.



This or a similar sticker may be located on the rear of the appliance. This sticker indicates that there are vacuum insulation panels (VIP) or perlite panels in the door and/or housing. This advice is only relevant to recycling. Do not remove the sticker.



This or a similar sticker may be located on the rear of the appliance. It refers to the Li-ion self-charging battery installed. This advice is only relevant to recycling. Do not remove sticker.

Li-ion



WARNING: Cold surface! Only touch with suitable hand protection.

This or similar sticker may be on the appliance and indicates the danger of frostbite.

Please note the warning messages and other specific advice in the other chapters:

	DANGER	Indicates an immediately hazardous situation which will lead to death or serious injuries if it is not avoided.
	WARNING	Indicates a hazardous situation which will lead to death or serious injuries if it is not avoided.
	CAUTION	Indicates a hazardous situation which will lead to minor or moderate injuries if it is not avoided.
	NOTICE	Indicates a hazardous situation which may lead to damage to property if it is not avoided.
	Note	Indicates useful instructions and tips.

3 Functionality of the Touch & Swipe display

You operate your appliance using the Touch & Swipe display. You select appliance functions in the Touch & Swipe display (hereafter referred to as display) by tapping them. If you do not perform any action on the display for 10 seconds, the display either jumps back to the higher-level menu or directly to the status display.

3.1 Navigation and symbol explanation

In the illustrations, different symbols are used to navigate the display. The following table describes these symbols.

Functionality of the Touch & Swipe display

Symbol	Description
	Briefly touch the display: Activates/deactivates function. Confirms selection. Opens submenu.
	Touch the display for a specified time (e.g. 3 seconds): Activates/deactivates function or value.
	Swipe left or right: Navigate in the menu.
	Briefly touch the Back symbol: Jumps back one menu level.
	Press and hold the Back symbol for 3 seconds: Jumps back to the status display.
	Briefly touch the Back symbol at the top left: Jumps back one menu level.
	Arrow with clock: It takes more than 10 seconds for the following message to appear in the display.
	Arrow with a time indication: It takes the specified amount of time until the following message appears in the display.
	“Open Settings menu” symbol: Navigates to the Settings menu and opens the settings menu. If necessary: Navigate to the desired function in the Settings menu. (see 3.2.1 Opening the Settings menu)
	“Open Advanced menu” symbol: Navigates to the Advanced menu and opens the advanced menu. If necessary: Navigate to the desired function in the Advanced menu. (see 3.2.2 Opening the expanded menu)
No action for 10 seconds	If you do not perform any action on the display for 10 seconds, the display either jumps back to the higher-level menu or directly to the status display.
Open door and close it again.	If you open the door and immediately close it again, the display jumps directly back to the status display.

Note: Illustrations of the display are shown in the English version.

3.2 Menus

The appliance functions are distributed over various menus:

Menu	Description
Main menu	When you switch the appliance on, you are automatically in the main menu. From here you can navigate to the most important appliance functions, to the Settings menu and to the Advanced menu.
 Settings menu	The Settings menu contains additional appliance functions for setting up your appliance.
 Advanced menu	The advanced menu contains special appliance functions for setting up your appliance. Access to the Advanced menu is protected by the numerical code 151 .

3.2.1 Opening the Settings menu

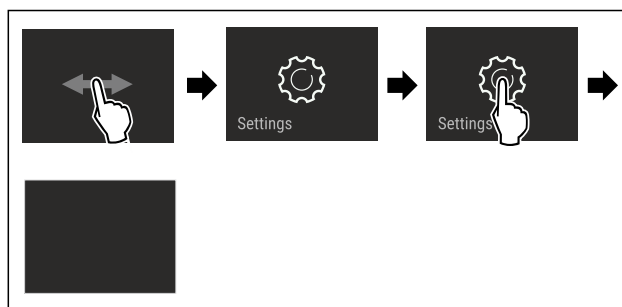

Fig. 5 Example illustration

- ▶ Carry out action steps according to the illustration.
- ▷ Settings menu is open.
- ▶ If necessary: Navigate to the desired function.

3.2.2 Opening the expanded menu

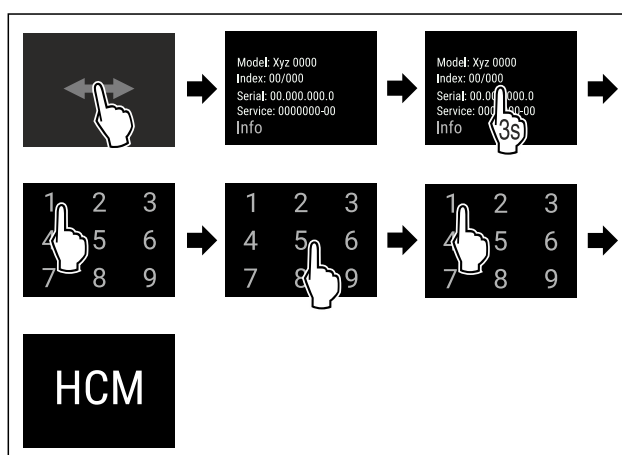

Fig. 6 Access with numerical code **151**

- ▶ Carry out action steps according to the illustration.
- ▷ The expanded menu is open.
- ▶ If necessary: Navigate to the desired function.

Putting into operation

3.3 Sleep mode

If you do not touch the display for 1 minute, the display switches to sleep mode. In sleep mode, the display brightness is dimmed.

3.3.1 Ending sleep mode

- ▶ Touch the display briefly with your finger.
- ▷ Sleep mode is ended.

4 Putting into operation

4.1 Installation conditions



WARNING

Fire hazard due to dampness!
If live parts or the mains lead become damp this may cause short circuits.

- ▶ The appliance is designed for use in enclosed areas. Do not operate the appliance outdoors or in areas where it is exposed to splash water or damp conditions.

4.1.1 Installation location



WARNING

Leaking coolant and oil!
Fire. The coolant contained in the appliance is eco-friendly, but also flammable. The oil contained in the appliance is flammable. Escaping coolant and oil can ignite if the concentration is high enough and in contact with an external heat source.

- ▶ Do not damage the pipelines of the coolant circuit and the compressor.

- Do not install appliance in direct sunlight, next to an oven, radiator or similar.
- The best place for installation is a dry and well ventilated room.
- If the appliance is installed in a very humid environment, condensation can form on the outside of the appliance. Always ensure good airflow and ventilation in the installation location.
- The more refrigerant there is in the appliance, the larger the space it is installed in must be. If the space is too small, any leak may create a flammable mixture of gas and air. For every 8 g of refrigerant, the installation space must be at least 1 m³. Information regarding the refrigerant can be found on the type plate inside the appliance.
- The floor of the location must be horizontal and even.
- The installation location must be able to withstand the weight of the appliance plus weight when stocked to maximum level. (see 9.1 Technical specifications)
- Use in hazardous areas is not permitted.

4.1.2 Electrical connection



WARNING

Danger of fire due to incorrect positioning!
If the mains cable or plug touches the back of the appliance, the vibration can damage the mains cable or the plug resulting in a short circuit.

- ▶ Make sure the mains cable is not trapped under the appliance when you position the appliance.
- ▶ Stand the appliance so that it is not touched by connectors or main cables.
- ▶ Do not connect any appliances to sockets in the area of the back of the appliance.
- ▶ Do **not** place and operate multi-sockets/power distributors and other electronic devices (such as halogen transformers) at the back of the appliances.

4.2 Appliance dimensions

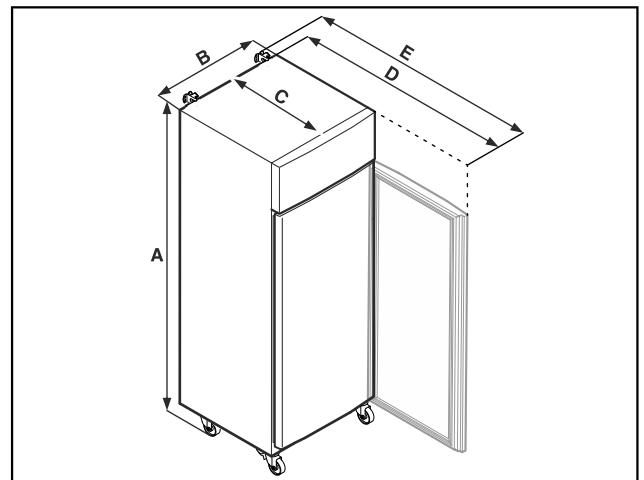

Fig. 7 Example illustration

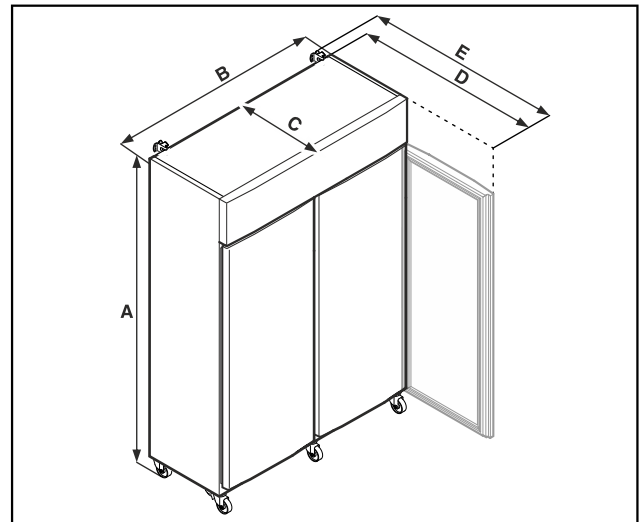

Fig. 8 Example illustration

	SFPvh 1402	SFPvh 6501
A	2135 mm	2135 mm
B	1427 mm	697 mm
C	867 mm	867 mm
D	1500 mm	1500 mm
E	1532 mm	1532 mm

SFPvh 8401	
A	2135 mm
B	787 mm
C	1017 mm
D	1740 mm
E	1772 mm

- A = appliance height including feet (minimum) / castors
 B = appliance width without handle
 C = appliance depth without handle
 D = appliance depth with door open
 F = appliance depth with protruding handle and anti-tipping device

4.3 Transporting appliance



DANGER

- Risk of injury and damage due to heavy appliance!
 ► Always transport the appliance with at least two people.



DANGER

- Risk of injury and damage due to the appliance tipping over!
 ► Pay attention to uneven floors and ramps when transporting appliances.

Note when transporting the appliance:

- Transport the appliance upright.
 ► If necessary: Dismantle two-door appliances for transport.

During first use:

- Transport the appliance packaged.

When transporting appliances after initial commissioning (e. g. moving or cleaning):

- Empty the appliance.
 ► Secure the door against unintentional opening.

4.4 Unpacking appliance

- Check the appliance and the packaging for damage during transport. Contact the supplier immediately if you suspect any damage. Do not connect appliance to the power supply.
 ► Remove all packaging materials from the rear or the side walls of the fridge that may prevent proper installation or prevent air flow and ventilation.

4.5 Connect power cable

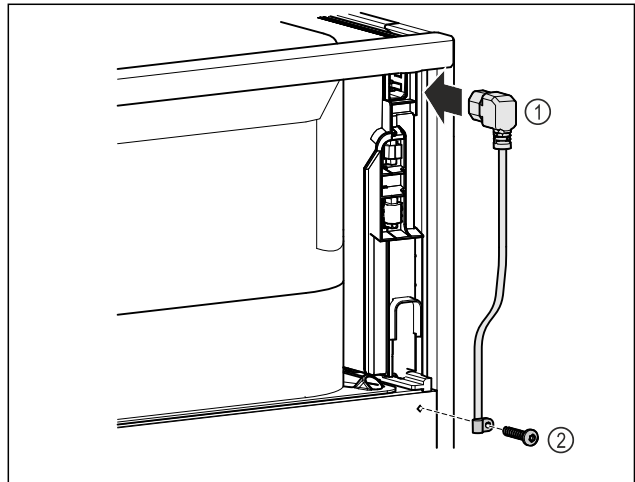

Fig. 9

- IEC socket of the power cable Fig. 9 (1) on the rear side of the appliance.
 ► Install mains tension relief. Fig. 9 (2)

4.6 Mounting the anti-tipping device



WARNING

Danger of injury and damage due to appliance tipping over! Danger to life and material damage to appliance. If you remove fully loaded shelves from the appliance, the appliance may tip over.

- Before putting the appliance into operation: install anti-tipping device in accordance with the instructions.

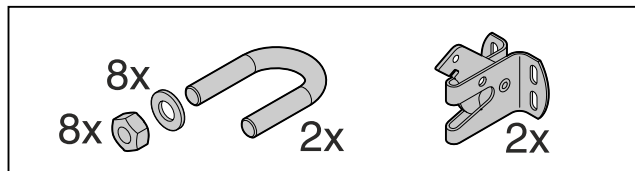

Fig. 10

The anti-tipping device is included with the appliance. It consists of a retaining part, bracket, 8 washers and 8 nuts.

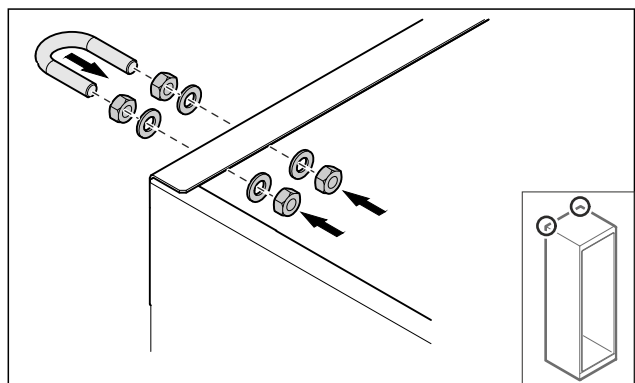

Fig. 11

- Mount the bracket with included washers and nuts on the appliance.
 ► Push appliance with fitted retaining parts against the wall.
 ► Level out the appliance.

Putting into operation

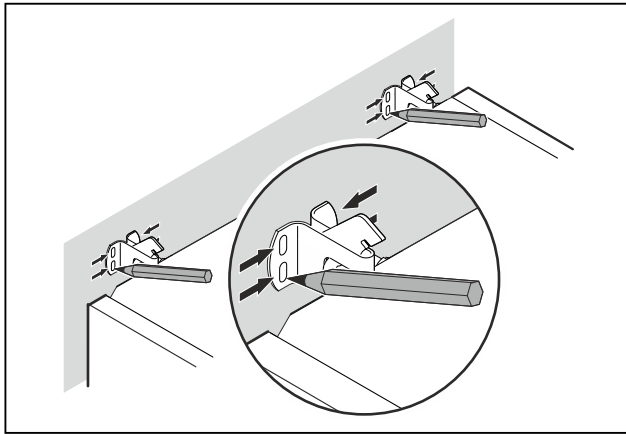

Fig. 12

- ▶ Make markings on the wall.
- ▶ Remove appliance.

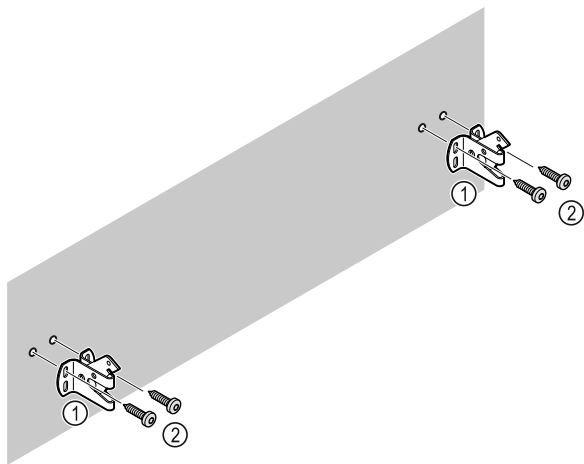

Fig. 13

Use fixing material (e.g. wall anchors) which is appropriate for the nature of the wall or floor (wood, concrete) and sufficient attachment points.

- ▶ Attach retaining hooks.

4.7 Installing appliance



CAUTION

Risk of injury and damage.

- ▶ Use 2 people to install appliance.



CAUTION

Risk of injury and damage.

The door can knock against the wall and become damaged as a result. In the case of glass doors, the damaged glass can cause injuries.

- ▶ Protect the door from knocking against the wall. Attach door stopper, e.g. felt stopper, to the wall.

- ▶ Connect all necessary components (e.g. mains cable) to the back of the appliance and route to the side.

Note

Cables can be damaged.

- ▶ Do not jam the cable when pushing the appliance back.
- ▶ The spacing between the top edge of the device and the room ceiling must be at least 300 mm.

4.8 Installing multiple appliances

NOTICE

Risk of damage due to condensation between the side walls.

- ▶ Do not install the appliance directly next to another fridge.
- ▶ Install appliances with a space 3 cm between appliances.
- ▶ Only install multiple appliances up to temperatures of 35 °C and 65% humidity next to one another.
- ▶ At higher levels of humidity, increase space between appliances.

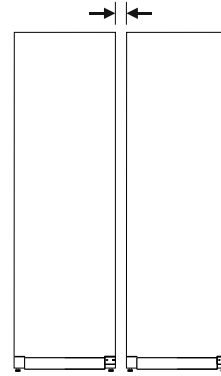

Fig. 14 Side-by-side installation

Note

A side-by-side kit is available as an accessory via Liebherr Customer Service. (see 9.3 Customer Service)

4.9 After installation

- ▶ Peel off the protective films. *
- ▶ Clean appliance. (see 8.3 Cleaning the appliance)
- ▶ If necessary: Disinfect the appliance.
- ▶ Keep the invoice so you have the appliance and dealer information available if needed.

4.10 Disposing of packaging



WARNING

Danger of suffocation due to packing material and plastic film!

- ▶ Do not allow children to play with packing material.

The packaging is made of recyclable materials:

- corrugated board/cardboard
- expanded polystyrene parts
- polythene bags and sheets
- polypropylene straps
- nailed wooden frame with polyethylene panel*

- ▶ Take the packaging material to an official collecting point.

4.11 Reversing the door opening direction

4.11.1 Safety notes



WARNING

Risk of injury if the door is not reversed correctly!

- ▶ The door may only be reversed by qualified personnel.



WARNING

- Risk of injury and material damage due to heavy door!
- Only perform the conversion if you can carry a weight of 45 kg.
- Always have someone help you carry out the conversion.

NOTICE

- Live parts!
- Damage to electrical components.
- Disconnect the power plug before reversing the door.

4.11.2 Tools



4.11.3 Opening the aggregate cover

- Open the door.

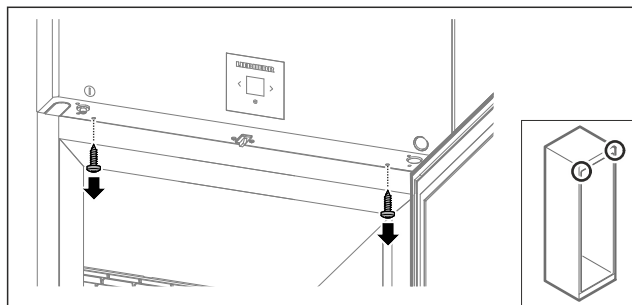

Fig. 15

- Remove the screws.

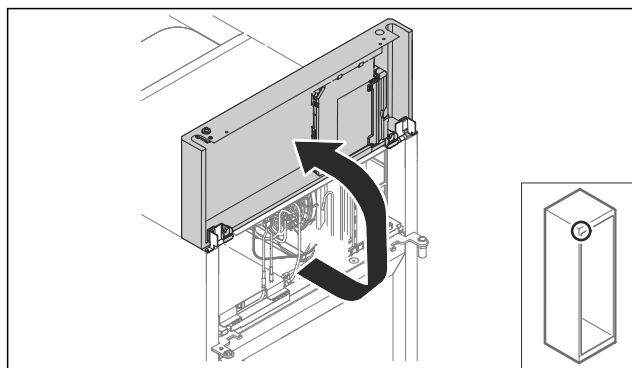

Fig. 16

- Lift the aggregate cover.
- Hold on to the cover.

-or-

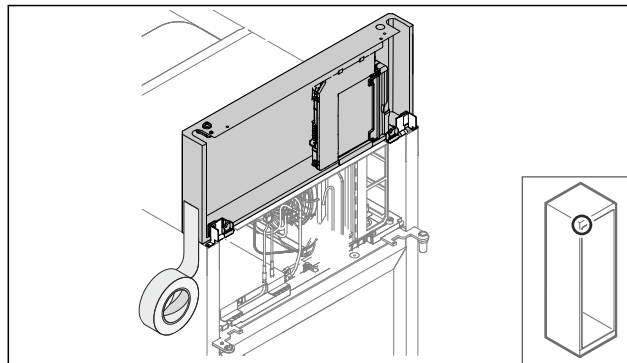

Fig. 17

- Fix the cover.

4.11.4 Removing the door

4.11.4 Removing the door (foamed door)

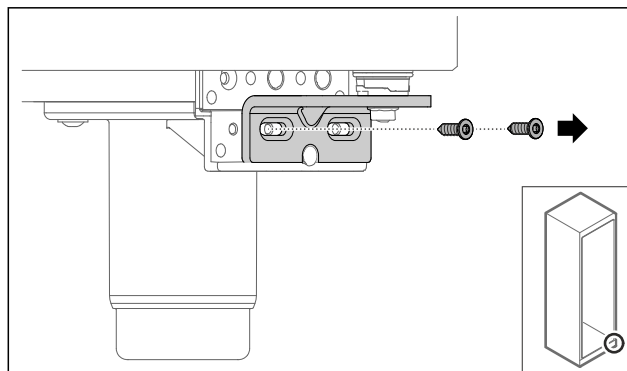

Fig. 18

- Remove the screws.

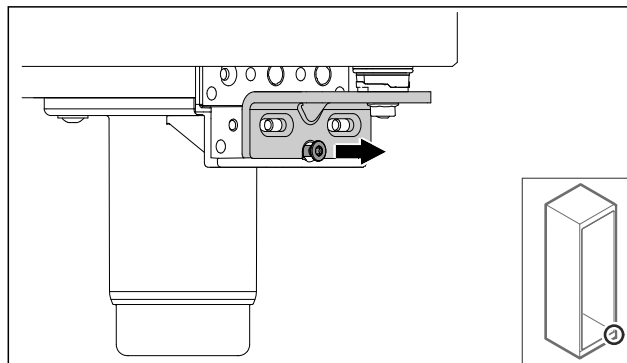

Fig. 19

- Loosen screw.

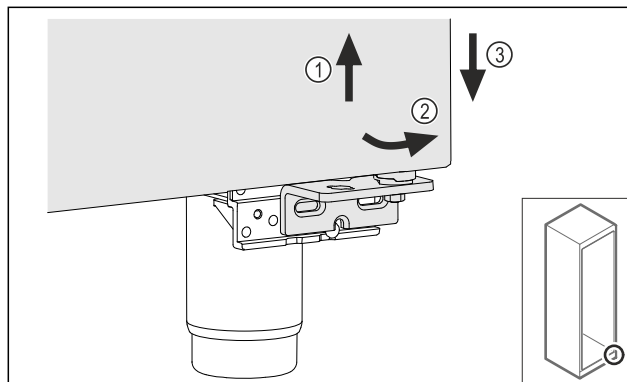

Fig. 20

- Lift the door slightly Fig. 20 (1), tilt it forwards at the bottom Fig. 20 (2) and lower it Fig. 20 (3).
- Place the door on a soft surface.

Putting into operation

▷ Foamed door is removed.

4.11.5 Converting the lower locking system

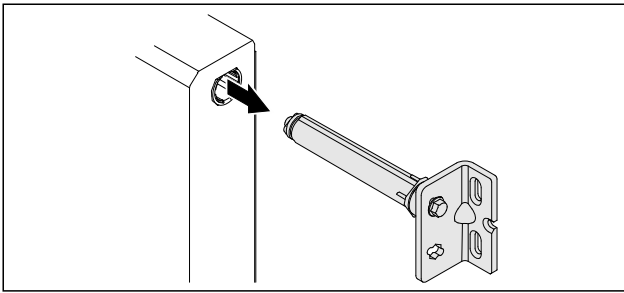

Fig. 21

▶ Pull the lower hinge bracket out of the door.

NOTICE

Danger of injury due to tensioned spring!

▶ Do not disassemble the door locking system Fig. 22 (1).

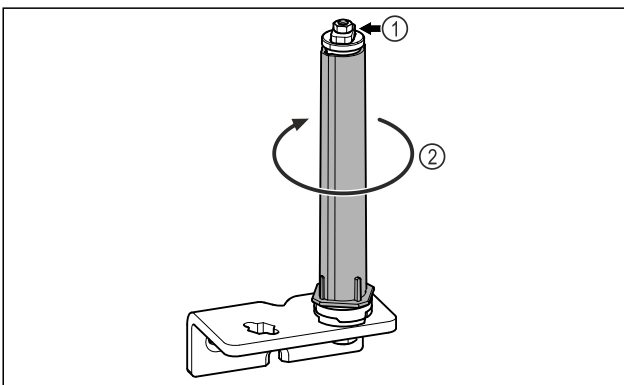

Fig. 22

▶ Turn the locking system Fig. 22 (2) until it clicks.
▷ Preload of the locking system is released.

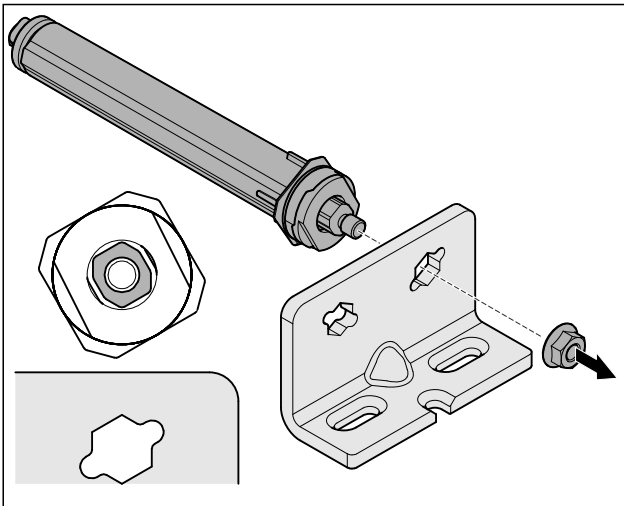

Fig. 23 Right-hinged

▶ Loosen nut.

Note

Incorrect alignment of the height adjustment washers.
Nuts no longer have sufficient hold.

▶ The washer must lock into the underside of the closing system.

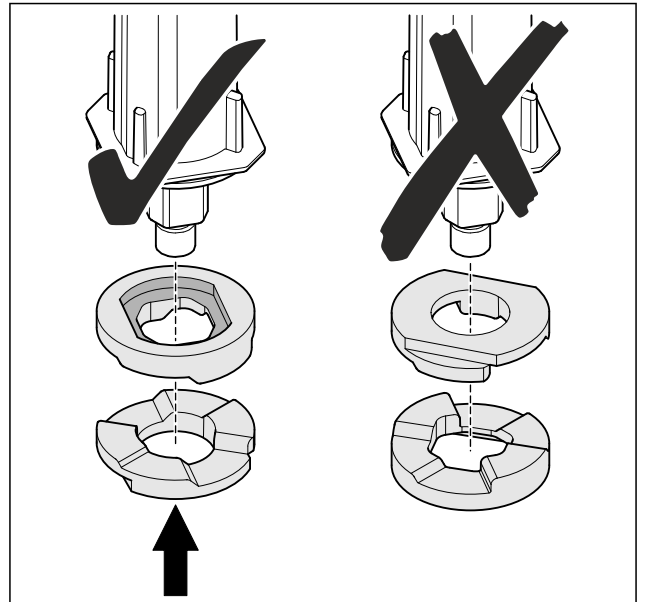

Fig. 24

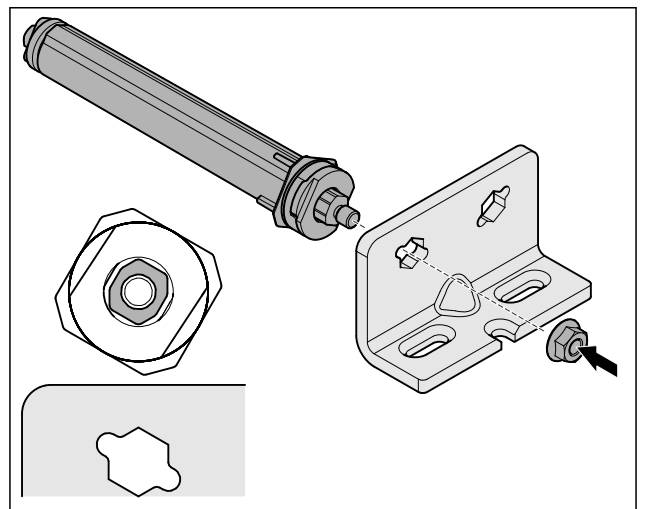

Fig. 25 Left-hinged

▶ Change over the closing system and tighten; observe the alignment of the closing system.
▷ Lower locking system has been converted.

4.11.6 Converting the upper locking system

4.11.6 Converting the upper locking system (foamed door)

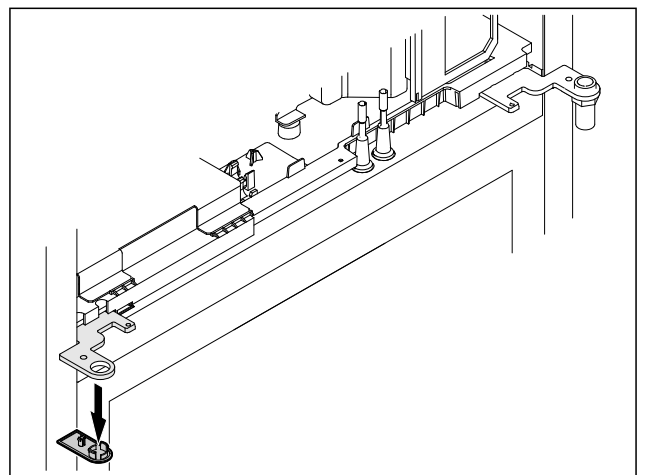

Fig. 26

- ▶ Remove cover.

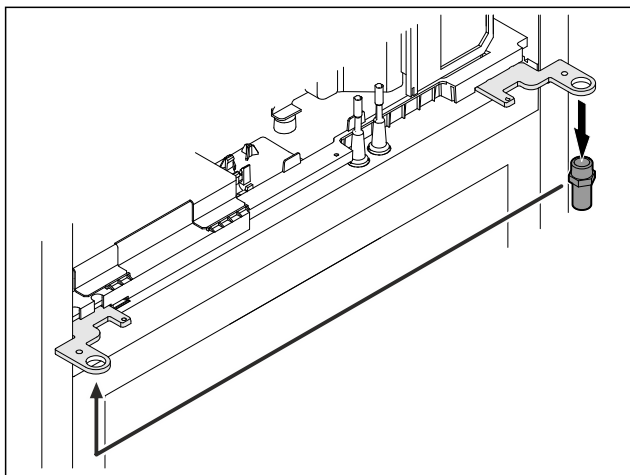

Fig. 27

- ▶ Re-locate the bolt in the hinge bracket.
- ▶ Tighten the bolt to a **torque of 12 Nm**.

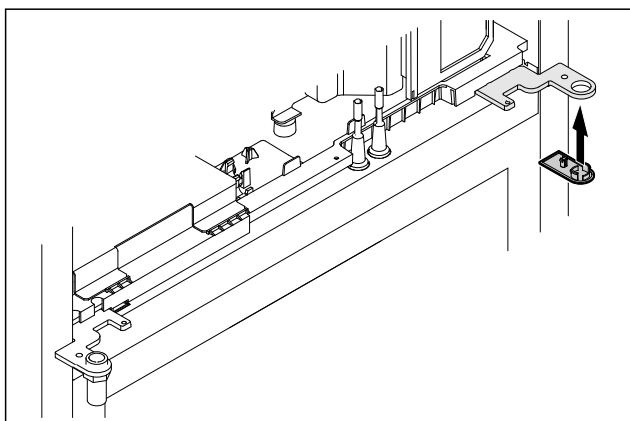

Fig. 28

- ▶ Put on the cover.
- ▷ Upper locking system has been converted.

4.11.7 Changing over the lock

4.11.7 Re-locating the lock (electronic lock)

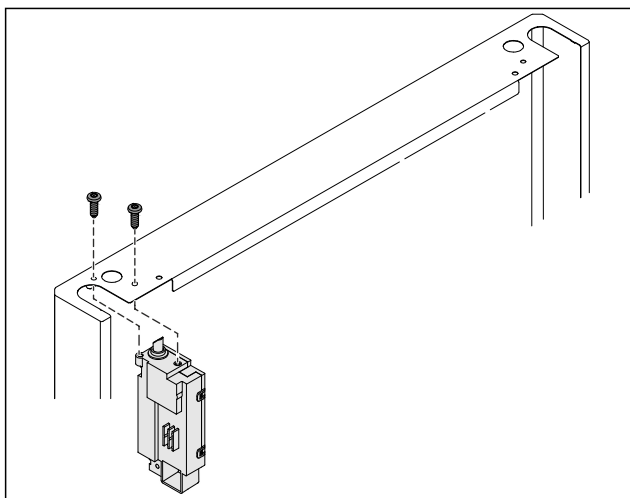

Fig. 29

- ▶ Remove the screws and remove the lock.
- ▶ The connected cable remains in the lock. Loosen any fasteners.

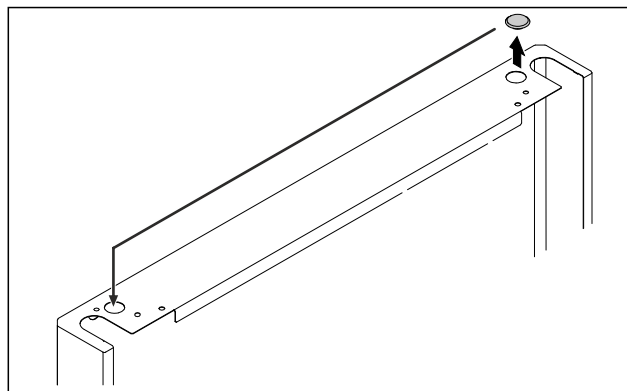

Fig. 30

- ▶ Swap the cover to the opposite side.

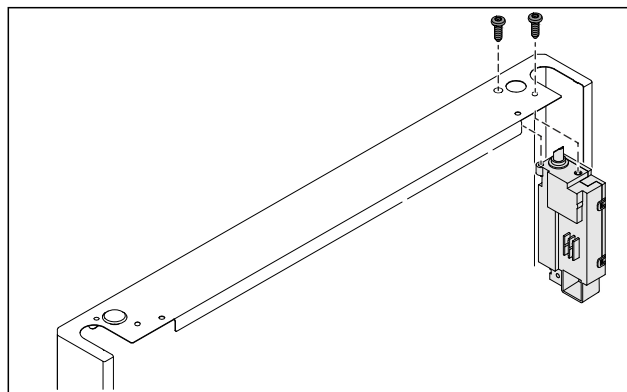

Fig. 31

- ▶ Insert the lock and screw in place.
- ▷ The electronic lock has been implemented.

4.11.8 Re-locating the swap bearing block

4.11.8 Re-locating the swap bearing block (casters)



WARNING

Danger of injury and damage due to appliance tipping over! Danger to life and material damage to appliance. If you remove the casters from the appliance, the appliance can tip over.

- ▶ Before performing a conversion on the appliance: Secure appliance against tipping over.

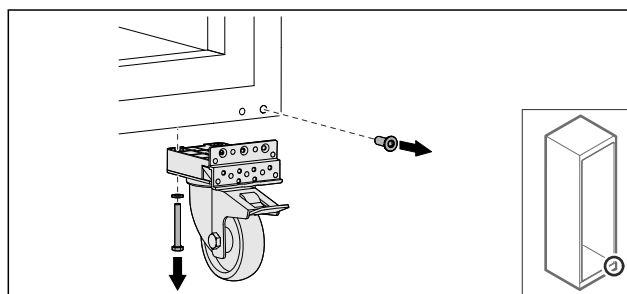

Fig. 32

- ▶ Unscrew and remove casters.

Putting into operation

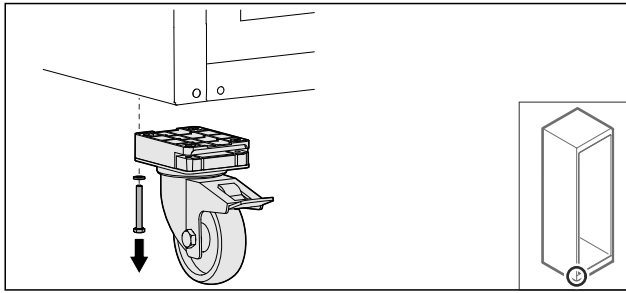

Fig. 33

- ▶ Unscrew and remove casters with bearing bracket.

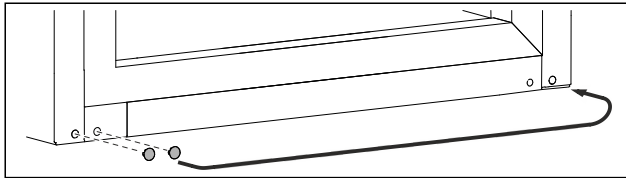

Fig. 34

- ▶ Swap over covers.

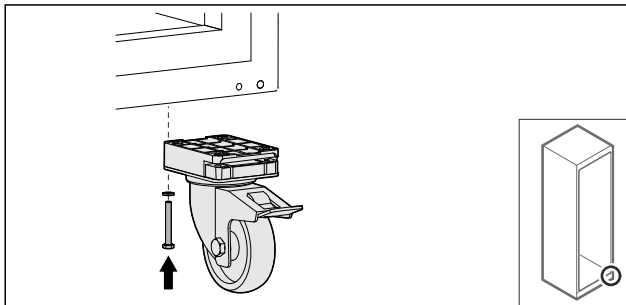

Fig. 35

- ▶ Screw on casters.

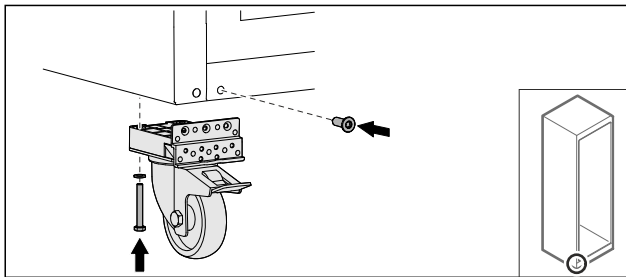

Fig. 36

- ▶ Screw on casters with bearing bracket.
- ▷ Swap bearing block is relocated.

4.11.9 Converting the door

4.11.9 Converting the door (foamed door)

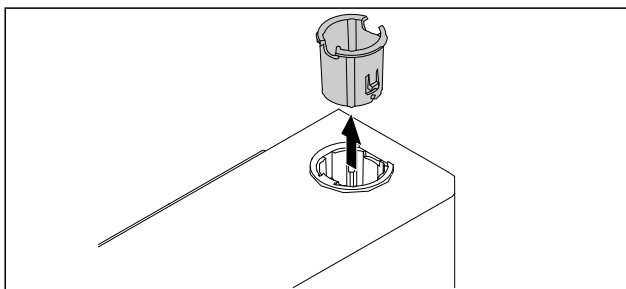

Fig. 37

- ▶ Pull out the hinge bushing on the opposite side.

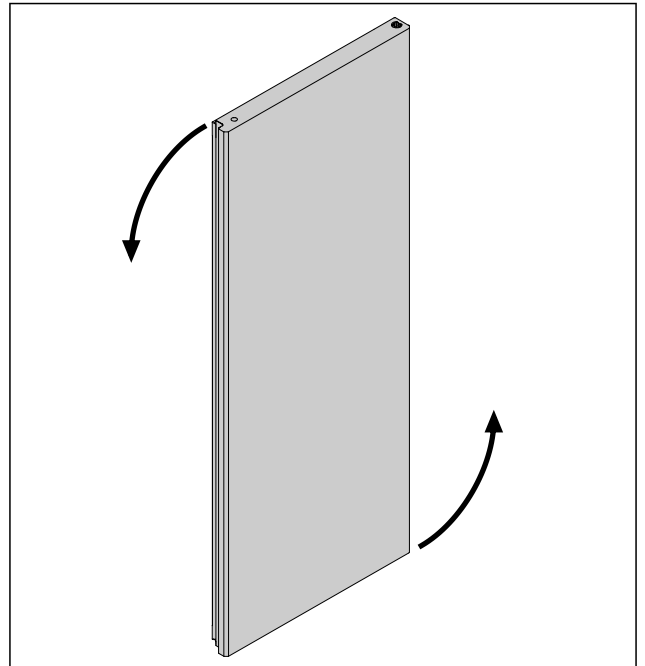

Fig. 38

- ▶ Turn the door 180°.

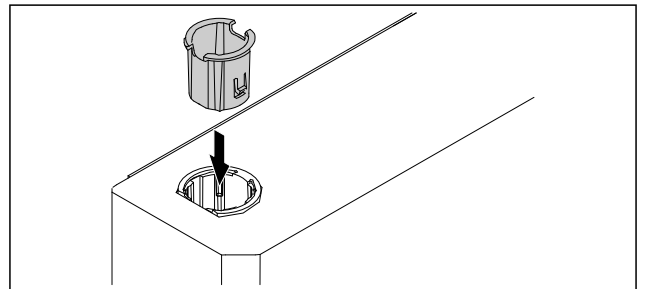

Fig. 39

- ▶ Insert the hinge bushing at the top of the hinge side (the flattened side faces outwards).
- ▷ Foamed door is converted.

4.11.10 Fitting the lower locking system

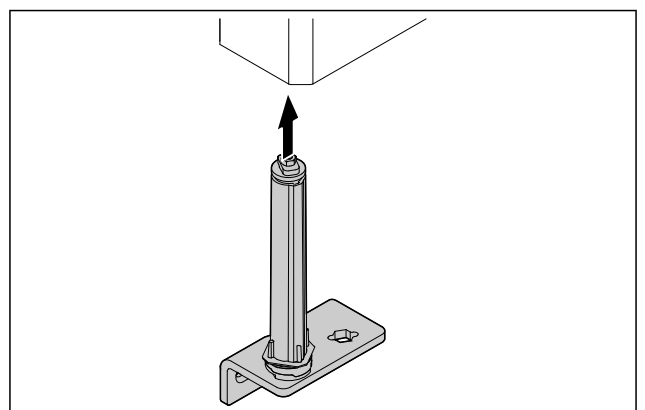

Fig. 40

- ▶ Slide the closing system into the door.

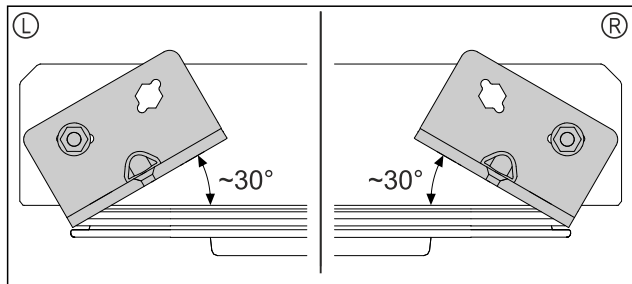

Fig. 41 Door from below

- ▷ Alignment of closing system installation for left-hinged (L) or right-hinged (R).

4.11.11 Fitting the door

4.11.11 Fitting the door (foamed door)

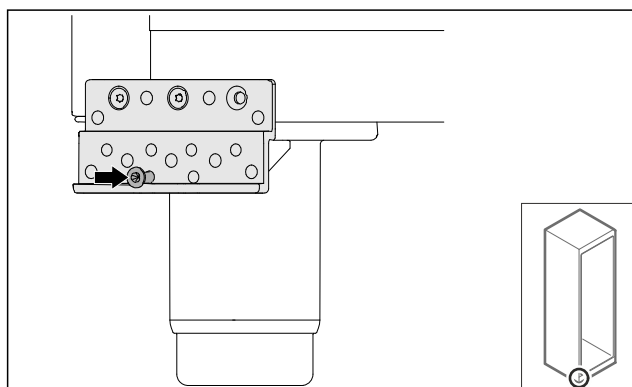

Fig. 42

- ▶ Slightly tighten the screw.

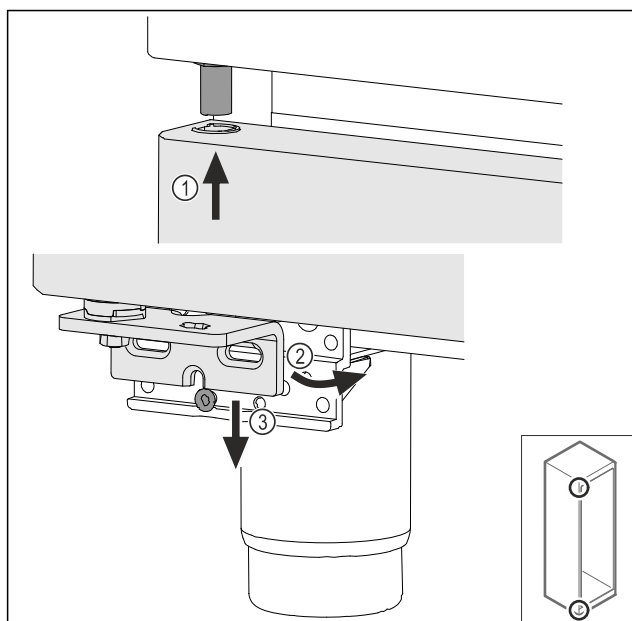

Fig. 43

- ▶ Insert the door slightly tilted at the top Fig. 43 (1), align the door straight Fig. 43 (2) and place it on the bottom of the swap bearing block screw Fig. 43 (3).

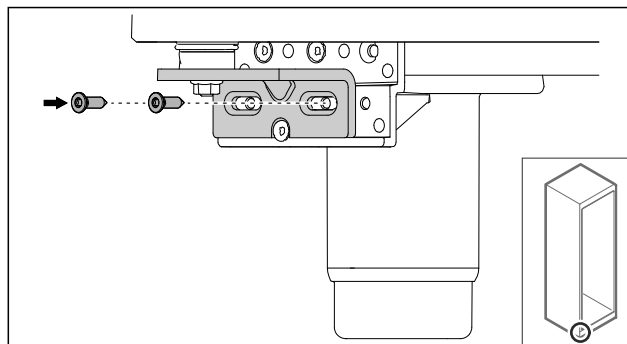

Fig. 44

- ▶ Screw on the door.
- ▷ Foamed door is fitted.

4.11.12 Closing the aggregate cover

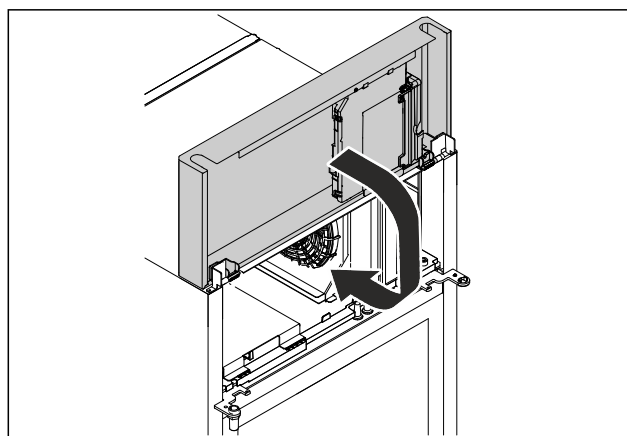

Fig. 45

- ▶ Close the aggregate cover.

Note

Do not pinch the cable.

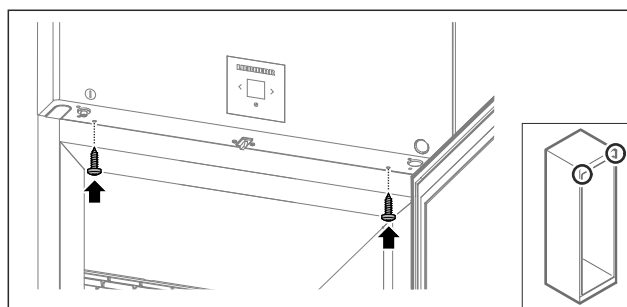

Fig. 46

- ▶ Screw on the aggregate cover.
- ▶ Close the door.
- ▷ The door hinge has been changed.

4.12 Aligning the door

4.12.1 Aligning the door horizontally

If the door is not straight, you can adjust it on the lower hinge.

Putting into operation

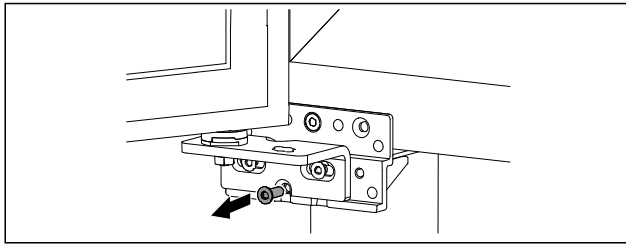

Fig. 47

- ▶ Remove the middle screw on the lower hinge.

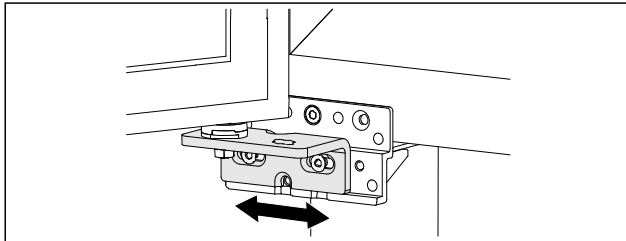

Fig. 48

- ▶ Slightly undo both screws and move the door with the hinge to the left or right.
- ▶ Fully tighten the screws (the middle screw is no longer needed).
- ▷ The door is now straight.

4.13 Connecting appliance



WARNING

- Danger of fire due to incorrect connection!
- Burns.
- Damage to the appliance.
- ▶ Do not use an extension cable.
- ▶ Do not use distributor blocks.

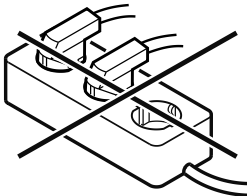

NOTICE

- Danger of damage to incorrect connection!
- Damage to the appliance.
- ▶ Do not connect the appliance to a stand-alone inverter, e.g. solar power systems and petrol generators.

Note

Only use the supplied mains cable.

Make sure that the following requirements are fulfilled:

- The appliance operated using **alternating current** only.
- The permitted voltage and frequency is printed on the type plate. The type plate position can be seen in the appliance overview chapter. (see 1.2 Overview of appliances and equipment)
- The socket is earthed according to the regulations and fused.
- The fuse tripping current is between 10 A and 16 A.
- The socket is easily accessible.
- ▶ Check the electrical connection.
- ▶ Insert the appliance plug into the back of the appliance. Ensure that they latch into place.
- ▶ Connect the mains plug to the power supply.
- ▷ The display switches to the standby symbol.

4.14 Switching on appliance (first use)

Ensure that the following requirements are met:

- Appliance is installed and connected.
- All adhesive strips, adhesive and protective films and transport locks are removed from inside and outside the appliance.

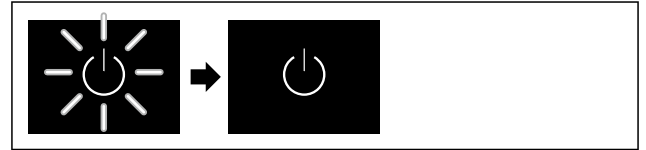

Fig. 49 Example illustration

- ▶ The standby symbol is flashing: Wait until the start process is complete.
- ▷ The display shows the standby symbol.

If the appliance has been supplied with factory settings, the screen language and the date/time first need to be set when using the appliance for the first time.

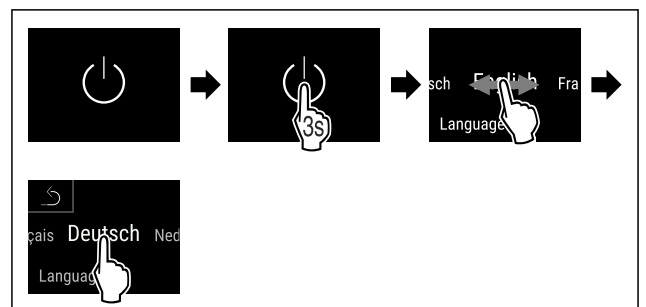

Fig. 50

- ▶ Carry out action steps according to the illustration.
- ▷ Language is set.

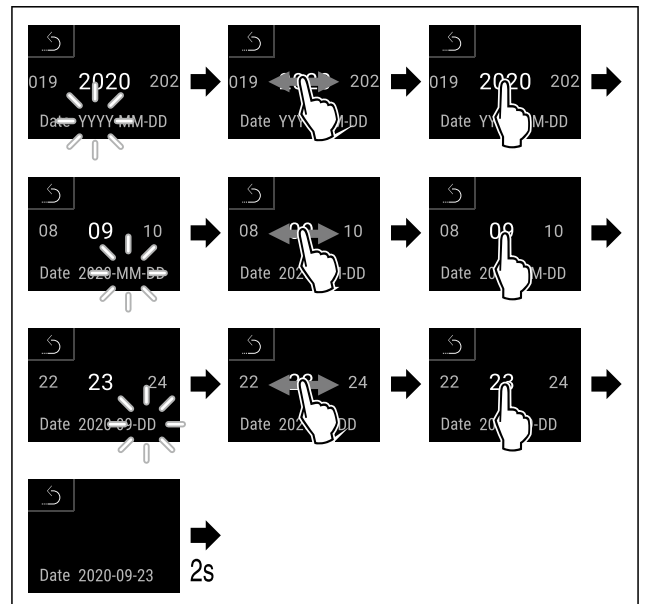

Fig. 51

- ▶ Carry out action steps according to the illustration.
- ▷ Date is set.

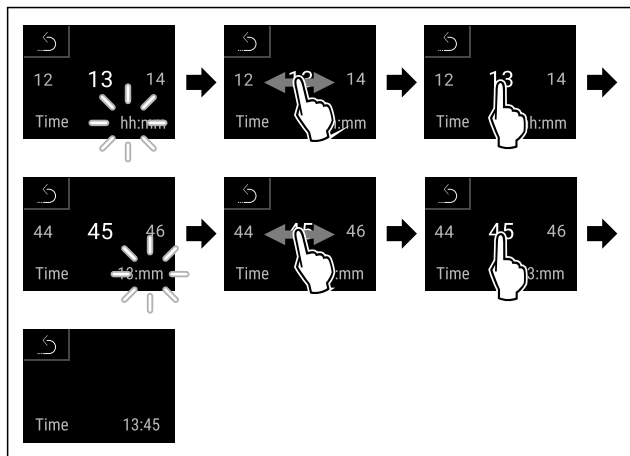

Fig. 52

- ▶ Carry out action steps according to the illustration.
- ▷ Time is set.

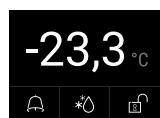

Fig. 53 Status display

- ▷ The appliance is ready for operation once the temperature appears in the display.
- ▷ The temperature display flashes until the set temperature is reached.

4.15 Using equipment

4.15.1 Inserting the snap strips

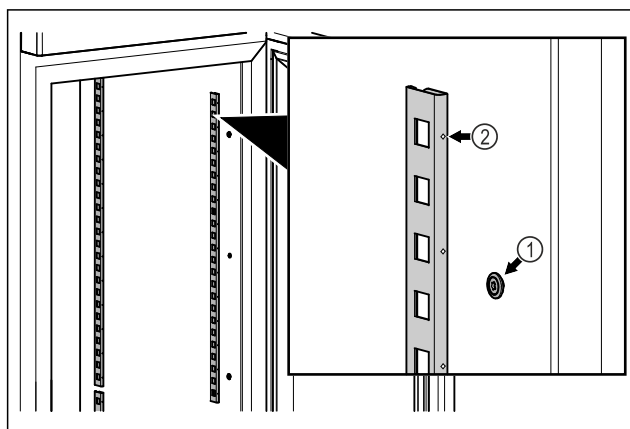

Fig. 54 Example illustration

- ▶ Hook the snap strips into the suspension Fig. 54 (1). Mark Fig. 54 (2) must point forwards.

4.15.2 Inserting support rail

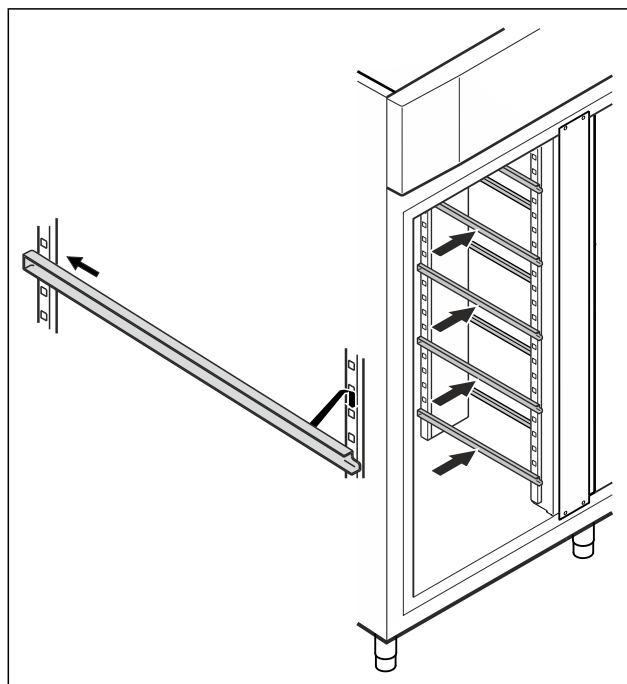

Fig. 55 Example illustration

- ▶ Insert support rail into rear snap-in bar and attach at front.

4.16 Centre grid shelf

4.16.1 Inserting centre grid shelf

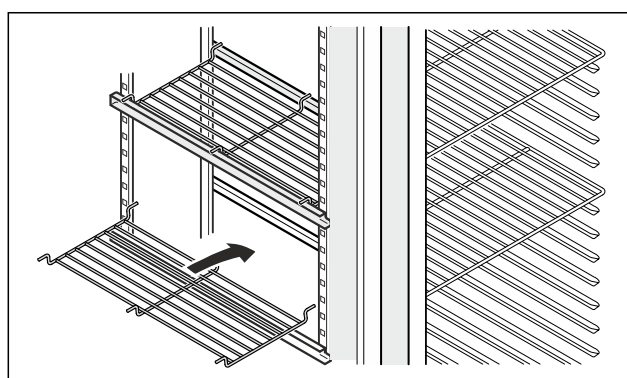

Fig. 56 Example illustration

- ▶ Place centre grid shelf on to support rails.

5 Storage

5.1 Information regarding storage

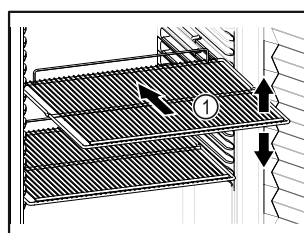



Fig. 57 Example illustration

Controls

When stocking observe the following:

- If there are adjustable shelves *Fig. 57 (1)*, position them as required.
 - Observe maximum load weight. (see 9.1 Technical specifications)
 - Do not load appliance until storage temperature has been reached (maintain cold chain).
 - Refrigerated goods must not touch the rear wall.
 - Do not store refrigerated goods beyond the rear stop of the support grates.
 - Keep liquids in closed containers.
 - Leave space when storing items for refrigeration to ensure good air circulation.
 - Do not stack refrigerated products above the indicated height. 
- This is important for free air circulation and even temperature distribution in the interior.

6 Controls

6.1 Control and display elements

The display provides a quick overview of the current appliance status, the temperature setting, the status of functions and settings as well as alarm and error messages.

Operation takes place directly on the Touch & Swipe display by swiping and touching.

Functions can be activated or deactivated and setting values can be changed.

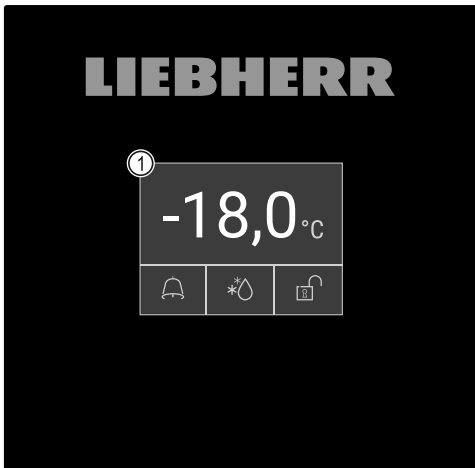

Fig. 58 Touch & Swipe display

(1) Status display

6.1.1 Status display



Fig. 59 Status display

(1) Actual temperature (2) Alarm status (3) Defrosting status (4) Door locking status













The status display is the output display.

It displays the temperature in the middle and three symbols in the lower area. The status display can show other display symbols.

Navigation to the functions takes place from the status display.

6.1.2 Display symbols

Display symbols provide information about the status of the appliance.

Symbol	Appliance status
	Standby symbol Appliance is switched off.
	Standby symbol (flashing) Appliance is starting up.
	Temperature (flashing) Target temperature not yet reached. Appliance cooling to temperature set.
	Status display (white frame) Appliance is locked.
	D in the display The appliance is in demo mode.
	Maintenance display (yellow) The time interval set has expired.
	Full data memory (yellow) The data memory (999 hours) is full. From now, the oldest data will be overwritten.
	Full alarm memory (yellow) The alarm memory is full. Delete individual alarms or entire memory.
	Manual door opening (yellow) The locked door was opened manually.
	Error symbol (red) Appliance is in error state.
	Background (blue) Active setting or active function
	Bar (increasing) Press for 3 seconds to activate setting.
	Bar (decreasing) Press for 3 seconds to deactivate setting.

Symbols on the status display

The additional symbols on the bottom of the status display enable fast access to alarm information and details regarding the appliance status.

Symbol	Appliance status
	Alarm symbol (grey) Alarm archive is empty. Pressing briefly opens the alarm archive.
	Alarm symbol (white) There are confirmed alarms in the alarm archive. Pressing briefly opens the alarm archive.
	Alarm symbol (red) There are still unconfirmed alarms in the alarm archive. Pressing briefly opens the alarm archive.
	Alarm symbol (red, flashing) There is an active alarm in the archive. Pressing briefly opens the alarm archive.
	Defrosting symbol (grey) No active defrosting process.
	Defrosting symbol (white, flashing) Manual defrosting process active. Pressing briefly opens the manual defrosting. (see 6.2.23 Defrosting)
	Defrosting symbol (white) Automatic defrosting process active. Function cannot be aborted.
	Door lock symbol (white, closed) The door lock is active. Pressing briefly opens the code entry for opening the door. (see 6.2.6 Door lock)
	Door lock symbol (white, open) The door lock is inactive. Brief press opens the code entry for locking the door. (see 6.2.6 Door lock)

Additional symbols on the status display

6.1.3 Acoustic signals

A signal sounds in the following cases:

- If a function or a value is confirmed.
- If a function or a value can either not be activated or not deactivated.
- As soon as an error occurs.
- If there is an alarm message.

The alarms can be switched on and off in the customer menu.

6.2 Appliance functions

6.2.1 Notes on the appliance functions

The appliance functions are set at the factory so that your appliance is fully functional.

Before you alter, activate or deactivate the device functions, make sure that the following requirements are met:

- You have read and understood the descriptions of how the display works. (see 3 Functionality of the Touch & Swipe display)
- You have familiarised yourself with the operating and display elements of your appliance. (see 6.1 Control and display elements)

6.2.2 Switching appliance on and off



This function makes it possible to switch the entire appliance on and off.

Switching on appliance

If demo mode is not activated:

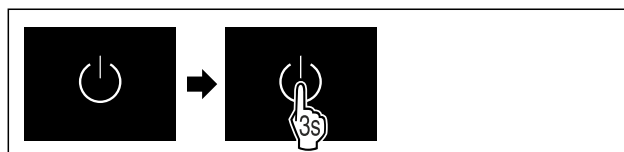

Fig. 60

- ▶ Carry out action steps according to the illustration.

If demo mode is activated:

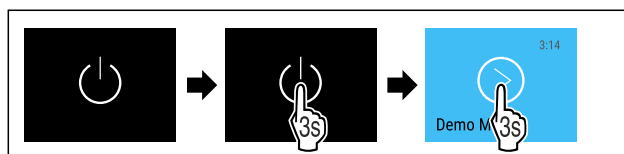

Fig. 61

- ▶ Carry out action steps according to the illustration.

Note

Deactivate demo mode before the countdown has finished.

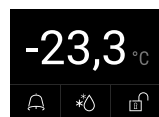

Fig. 62 Status display

- ▷ The temperature appears in the display.

Switching off appliance



Fig. 63

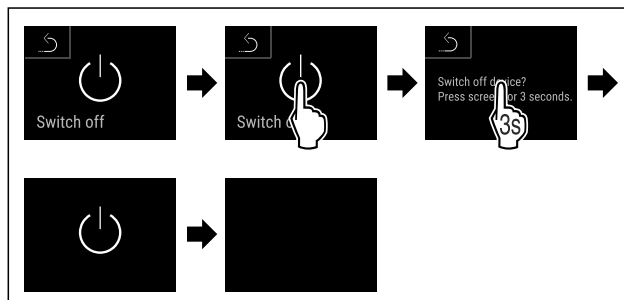

Fig. 64

- ▶ Carry out action steps according to the illustration.
- ▷ Standby symbol is shown in the display.
- ▷ The display switches off automatically after around 10 minutes.

Controls



6.2.3 Temperature

The temperature depends on the following factors:

- How often the door is opened
- How long the door is open for
- The room temperature of the installation site
- The type, temperature and amount of food

Note

The temperature may differ from the temperature displayed in some areas of the interior.

At the correct temperature, frozen food will keep for longer. This avoids disposing of food unnecessarily.

Setting temperature

The following steps describe how to increase the temperature, e.g. from -33.3 °C to -31.8 °C.



Fig. 65

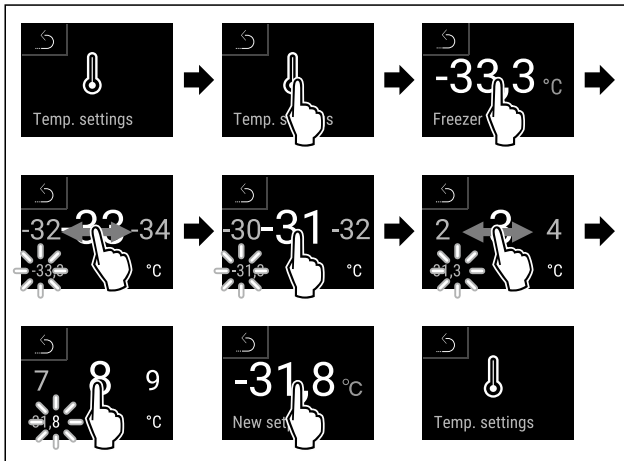

Fig. 66

- ▶ Carry out action steps according to the illustration.
- ▷ Temperature is set.



6.2.4 Temperature recording

The appliance displays the minimum and maximum temperatures of the interior via this function. The recording of these temperatures starts automatically after the appliance is switched on; they are recorded at one minute intervals. A note indicating that the data memory is full is displayed after 999 hours (approx. 40 days). The temperature recording should then be reset.

Note

The entire temperature history as well as alarm and service messages are also recorded independently of this function. This data can be exported and backed up on a USB storage medium. (see 6.2.24 Data download / Datalogging)

If there is an additional product sensor installed on the appliance, there is the option of selecting this sensor to display the minimum and maximum temperatures. (see 6.2.25 Sensor calibration)

Note

The temperature recording should be reset once **after reaching the set temperature** when the appliance is commissioned. (see Resetting temperature recording) This ensures that the value for the maximum temperature is a meaningful value.

Displaying temperature recording

The temperature recording displays the length of the recording and the minimum and maximum temperatures measured during this period of time.



Fig. 67



Fig. 68

- ▷ Status screen with the temperature recordings is displayed.

Resetting temperature recording

The displayed minimum and maximum temperatures can be reset at any time. This deletes the displayed values and the recording interval starts again.



Fig. 69

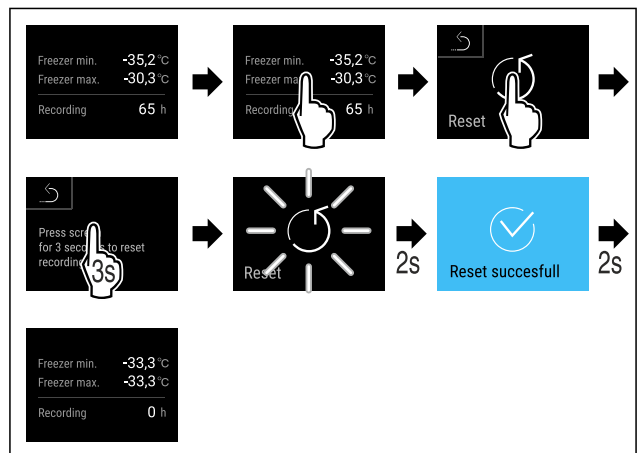

Fig. 70

- ▶ Carry out action steps according to the illustration.
- ▷ Temperature recording is reset.



6.2.5 Lighting

The appliance is fitted with interior lighting.

When you open the appliance door, the interior lighting switches on. You can also deactivate this function.

6.2.6 Door lock

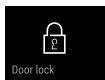

The appliance is fitted with an electronic door lock. **When using the first time, the door is unlocked** and you can open it.

This function means the appliance can be secured against the unwanted removal of items.

You have the following setting options for this:

- Lock door using door code.
- Unlock door using door code.
- Activate automatic locking.
- Deactivate automatic locking.
- Set time delay for automatic locking.
- Change the door code. (see 6.2.9 Access codes)
- Reset the door code. (see 6.2.9 Access codes)
- Pair remote control. (see 6.2.10 Remote control)

Locking door using door code

Note

- ▶ In the following example, the factory-set PIN code: **1 1 1 1** is used.

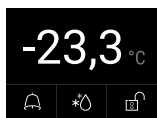

Fig. 71 Status display

Starting from the status display, the door code entry begins by pressing the open padlock symbol.

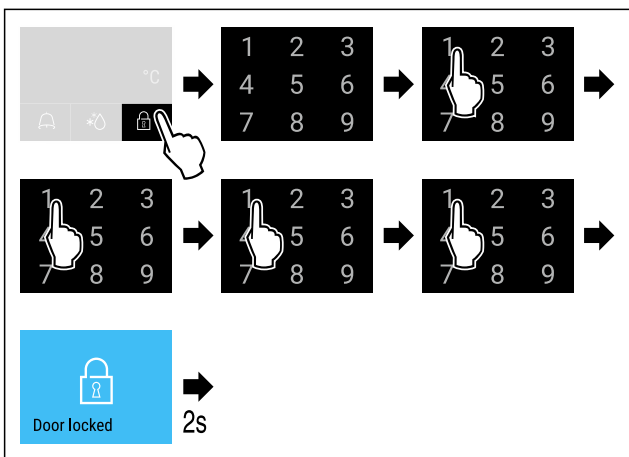

Fig. 72 Locking door using door code 1 1 1 1.

- ▶ Carry out action steps according to the illustration.



Fig. 73 Status display with white border

- ▷ The door is locked.

Unlocking door using door code

Note

- ▶ In the following example, the factory-set PIN code: **1 1 1 1** is used.

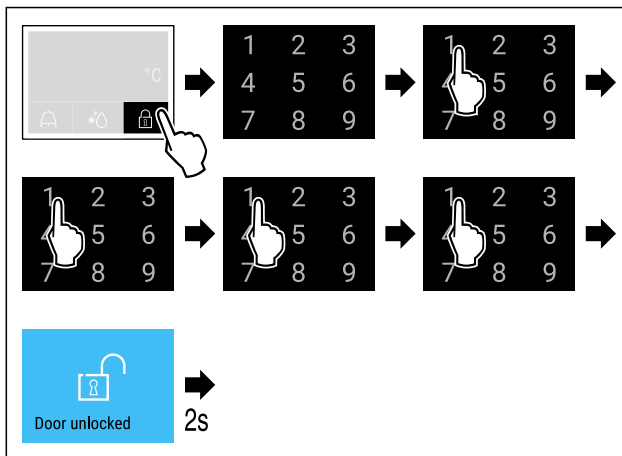

Fig. 75 Unlock the door with door code 1 1 1 1.

- ▶ Carry out action steps according to the illustration.

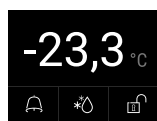

Fig. 76 Status display

- ▷ The status display with an open padlock symbol appears.
- ▷ The door is unlocked.

Activating automatic locking

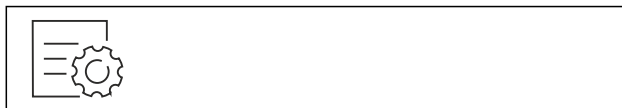

Fig. 77

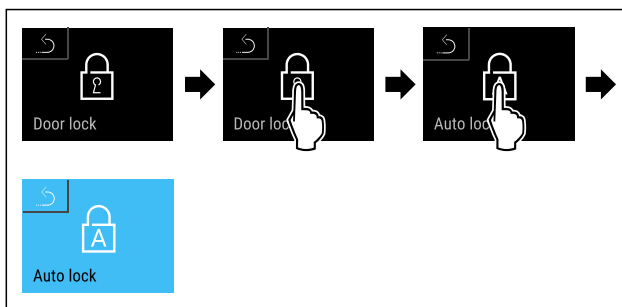

Fig. 78

- ▶ Carry out action steps according to the illustration.
- ▷ Automatic locking is activated.
- ▷ The time delay (see Setting time delay for automatic locking) can now be set.

Note

You can continue to lock and unlock the door using the remote control (see 6.2.10 Remote control) or by entering the door code.

Deactivating automatic locking

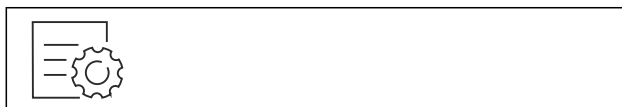

Fig. 79

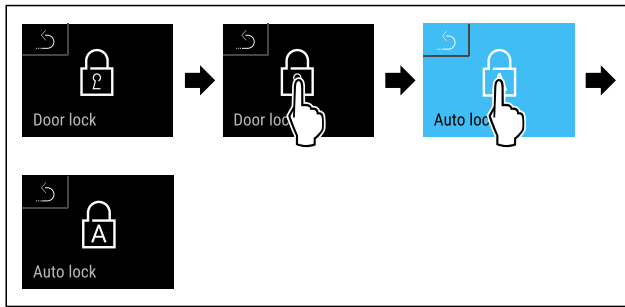

Fig. 80

- ▶ Carry out action steps according to the illustration.
- ▷ Automatic locking is deactivated.

Setting time delay for automatic locking

This function sets the time delay of the automatic door lock after a door is opened.

Make sure that the following requirements are fulfilled:

- The automatic door locking (see Activating automatic locking) is activated.



Fig. 81

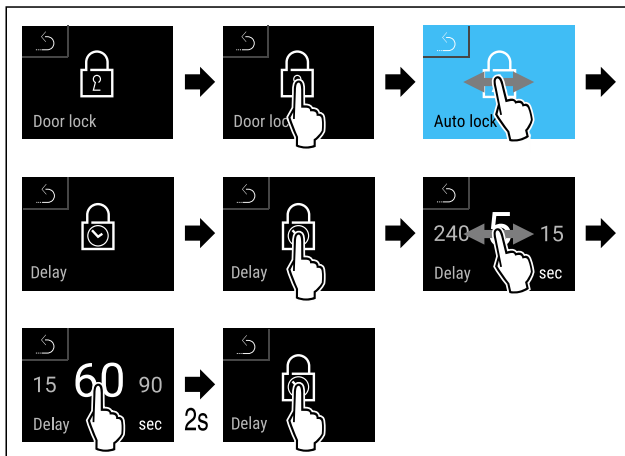

Fig. 82 The following values can be set: 5, 15, 60, 90, 120, 180 and 240 seconds

- ▶ Carry out action steps according to the illustration.
- ▷ Time delay is set.

Changing door code

(see 6.2.9 Access codes)

Resetting door code

(see 6.2.9 Access codes)

Pairing remote control

(see 6.2.10 Remote control)



6.2.7 SmartLock

To prevent the removal of the cooled produce, this function enables automatic door locking after the temperature alarm has been triggered. (see 6.2.26 Temperature alarm) The locking delay time can be set. The door can then only be opened with the SmartLock PIN code.

Application:

- Activating the SmartLock.

- Deactivating the SmartLock.
- Setting the locking delay.
- Unlocking the door lock with the SmartLock PIN code.
- Changing the SmartLock PIN code. (see 6.2.9 Access codes)
- Resetting the SmartLock PIN code. (see 6.2.9 Access codes)

Activating SmartLock

Note

- ▶ In the following example, the factory-set PIN code: **1 1 1 1** is used.



Fig. 83

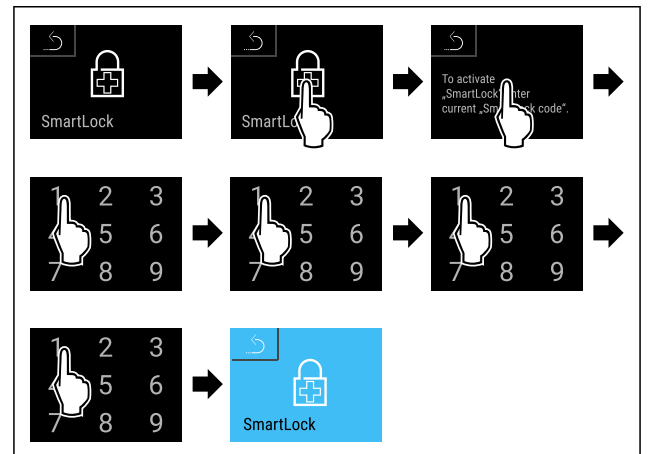

Fig. 84

- ▶ Carry out action steps according to the illustration.
- ▷ SmartLock is activated.
- ▷ The locking delay interval can now be selected. (see Setting locking delay)

Deactivating SmartLock

Note

- ▶ In the following example, the factory-set PIN code: **1 1 1 1** is used.



Fig. 85

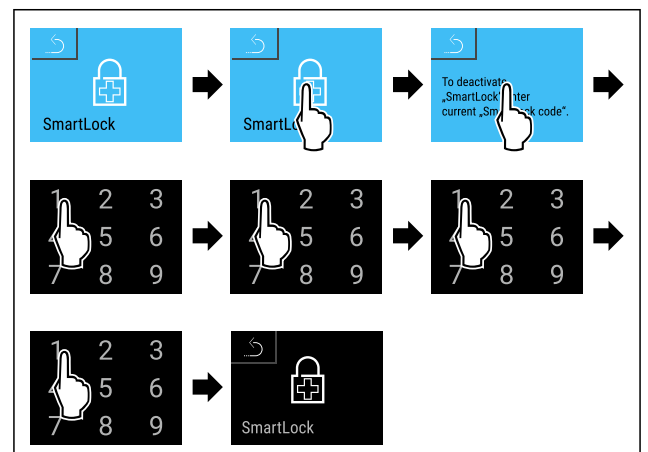

Fig. 86

- ▶ Carry out action steps according to the illustration.
- ▷ SmartLock is deactivated.

Setting locking delay

Make sure that the following requirements are fulfilled:

- SmartLock must be activated. (see Activating SmartLock)



Fig. 87

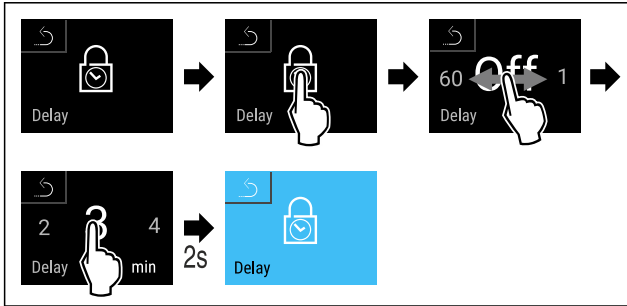

Fig. 88 The following values can be set: Off (no waiting time) up to 60 minutes; in 1-minute increments

- ▶ Carry out action steps according to the illustration.
- ▷ The time for the locking delay has been set.

Unlocking door lock with SmartLock PIN code

After the temperature alarm has been triggered (see 6.2.26 Temperature alarm) the door is locked automatically via the SmartLock function.

Opening is now only possible with the SmartLock PIN code.

Note

- ▶ In the following example, this SmartLock PIN code is used: **2 3 4 5**

Entry of the SmartLock PIN code starts from the status display. Information about the SmartLock function and the temperature recording for the temperature alarm are displayed.

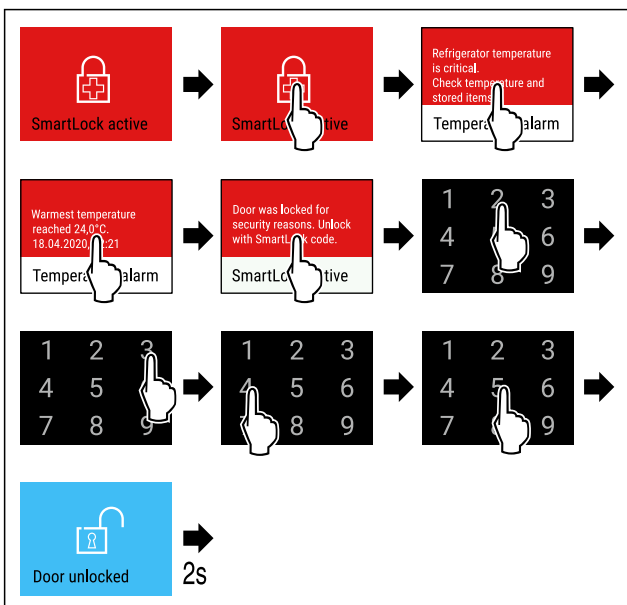

Fig. 89

- ▶ Carry out action steps according to the illustration.
- ▷ The door is unlocked.

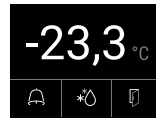

Fig. 90 Status display

- ▷ The temperature appears in the display.

Changing the SmartLock PIN code

(see 6.2.9 Access codes)

Resetting the SmartLock PIN code

(see 6.2.9 Access codes)

6.2.8 Settings menu access protection



This function enables the settings menu access protection via a four-digit PIN code.

Application:

- Prevent settings and functions being changed unintentionally.
- Prevent appliance being switched off unintentionally.
- Prevent temperature being set unintentionally.

Activating the settings menu access protection

Note

- ▶ In the following example, the factory-set PIN code: **1 1 1 1** is used.

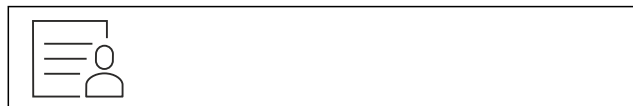

Fig. 91

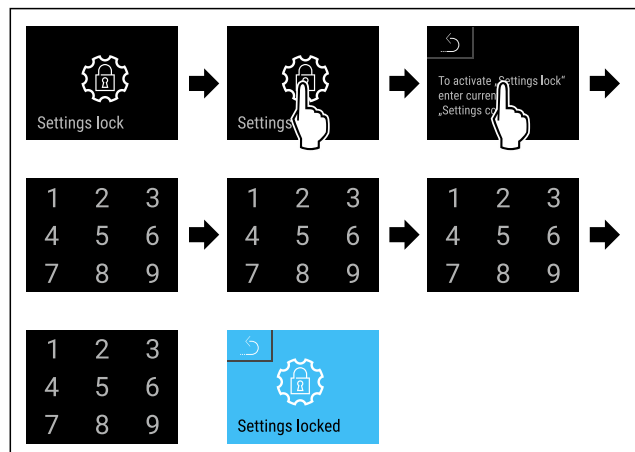

Fig. 92

- ▶ Carry out action steps according to the illustration.
- ▷ Settings menu access protection is activated.

Changing the access protection PIN code for the settings menu

(see 6.2.9 Access codes)

Deactivating the settings menu access protection

Note

- ▶ In the following example, the factory-set PIN code: **1 1 1 1** is used.



Fig. 93

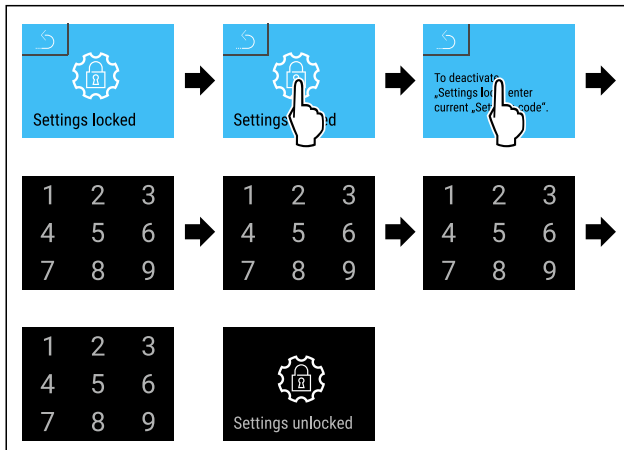

Fig. 94

- ▶ Carry out action steps according to the illustration.
- ▷ Settings menu access protection is deactivated.

Opening protected settings menu

If the settings menu access protection is active, it is necessary to enter the PIN code to open the settings menu. The settings menu remains unlocked for 20 minutes after entering the correct PIN code.

Note

- ▶ In the following example, the factory-set PIN code: **1 1 1 1** is used.

Access protection for the settings menu must be active.

- ▶ Swipe left or right until corresponding function is displayed.

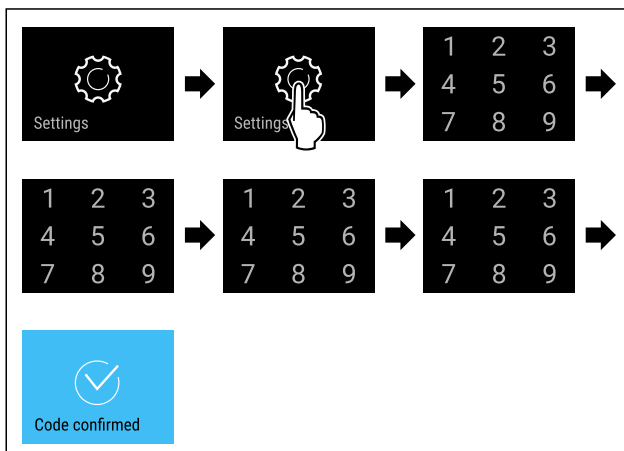

Fig. 95

- ▶ Carry out action steps according to the illustration.
- ▷ PIN code is correct: settings menu opens.

6.2.9 Access codes

Various settings are possible.

Application:

- Changing the door code.
- Resetting the door code.
- Changing the setting code.
- Resetting the setting code.
- Changing the SmartLock code.
- Resetting the SmartLock code.



Door code

Changing door code

The setting allows the door code for the door lock to be changed.

The setting is made in three stages:

- Entering the old door code
- Entering the new door code
- Confirming the new door code

Note

- ▶ In the following example, the default factory set door code **1 1 1 1** is changed.
- ▶ The new door code is: **2 3 4 5**



Fig. 96

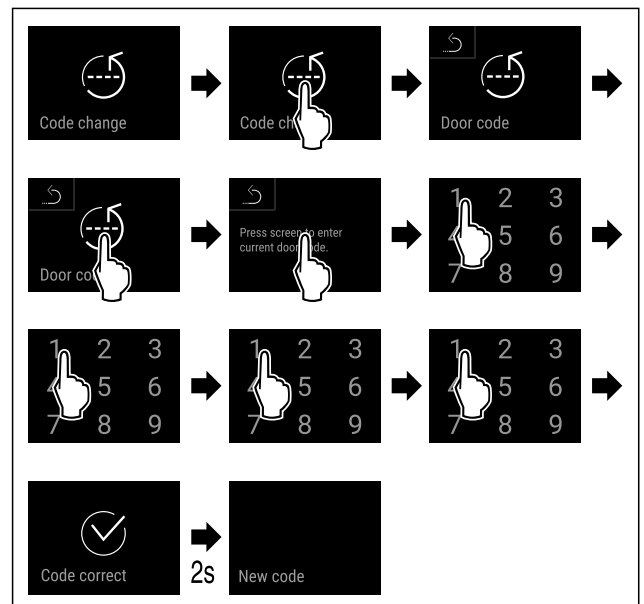

Fig. 97

- ▶ Carry out action steps according to the illustration.
- ▷ Entry of the old door code successful.

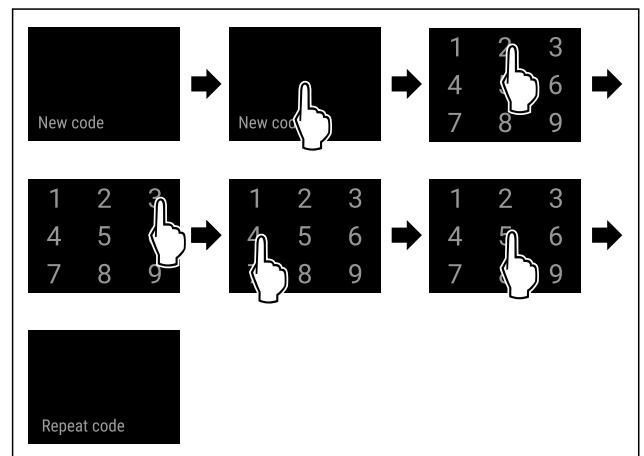

Fig. 98

- ▶ Carry out action steps according to the illustration.
- ▷ Entry of the new door code successful.

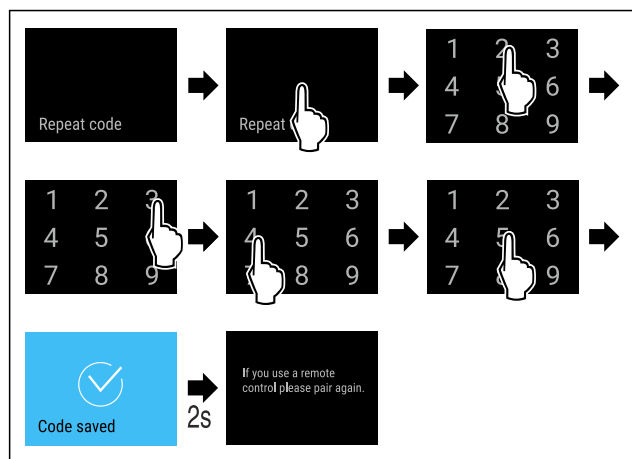

Fig. 99

- ▶ Carry out action steps according to the illustration.
- ▷ Confirmation of the new door code successful.
- ▷ The door code has been changed.
- ▶ Re-pair the remote control. (see 6.2.10 Remote control)

Resetting door code

Door code forgotten or not known.

- ▶ Reset appliance to factory settings. (see 6.2.33 Resetting to factory settings)
- ▷ The appliance is reset to the original settings.
- ▷ The factory setting for the door code is: **1 1 1 1**

Settings menu access protection



Changing the settings code

This setting allows the setting code for settings menu access protection to be changed.

The setting is made in three stages:

- Entering the old settings code
- Entering the new settings code
- Confirming the new settings code

Note

- ▶ In the following example, the default factory-set settings code **1 1 1 1** is changed.
- ▶ The new settings code is: **2 3 4 5**



Fig. 100

The settings menu access protection must be active. (see 6.2.8 Settings menu access protection)

- ▶ Swipe left or right until corresponding function is displayed.

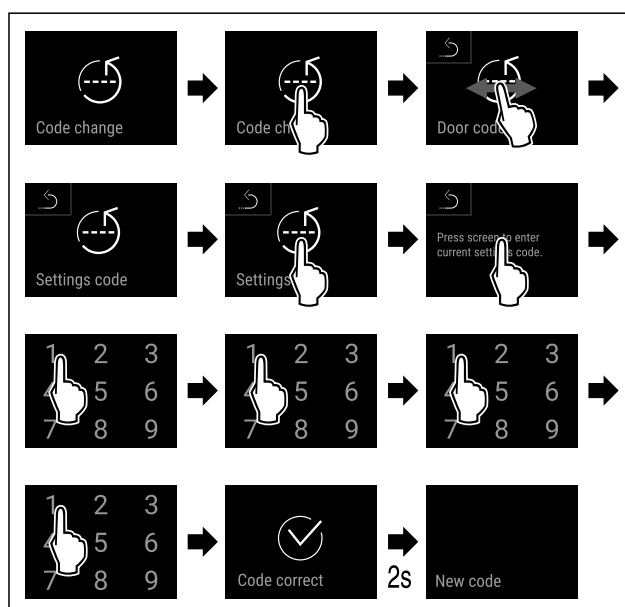

Fig. 101

- ▶ Carry out action steps according to the illustration.
- ▷ Entry of the old settings code successful.

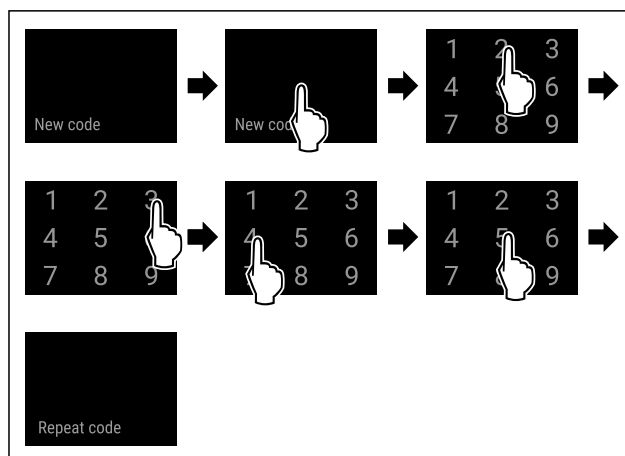

Fig. 102

- ▶ Carry out action steps according to the illustration.
- ▷ Entry of the new settings code successful.

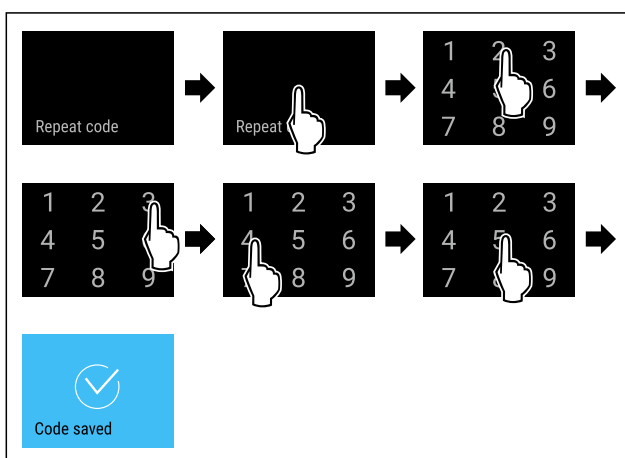

Fig. 103

- ▶ Carry out action steps according to the illustration.
- ▷ Confirmation of the new settings code successful.
- ▷ The settings code has been changed.

Controls

Resetting the setting code

The setting code for the settings menu access protection has been forgotten or is not known.

- ▶ Reset appliance to factory settings (see 6.2.33 Resetting to factory settings).
- ▷ The appliance is reset to the original settings.
- ▷ The factory-set setting code is: **1 1 1 1**



SmartLock

Changing SmartLock code

This setting makes it possible to change the SmartLock code.

The setting is made in three stages:

- Entry of the old SmartLock code
- Entry of the new SmartLock code
- Confirmation of the new SmartLock code

Note

- ▶ In the following example, the default factory-set SmartLock code **1 1 1 1** is changed.
- ▶ The new SmartLock code is: **2 3 4 5**



Fig. 104

SmartLock must be active. (see 6.2.7 SmartLock)

- ▶ Swipe left or right until corresponding function is displayed.

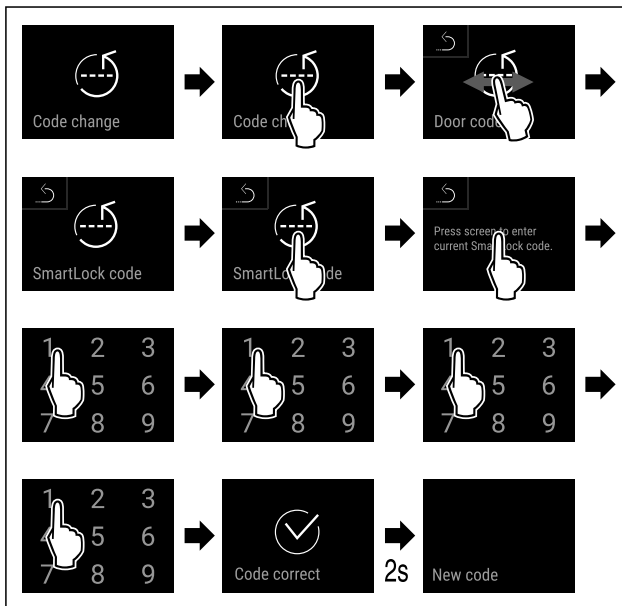

Fig. 105

- ▶ Carry out action steps according to the illustration.
- ▷ Entry of the old SmartLock code successful.

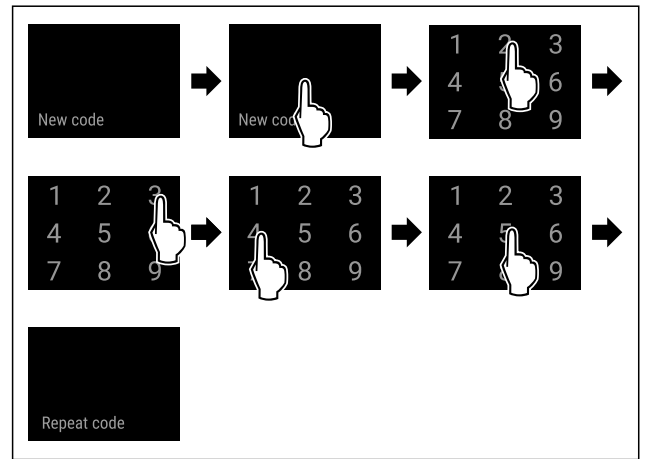

Fig. 106

- ▶ Carry out action steps according to the illustration.
- ▷ Entry of the new SmartLock code successful.

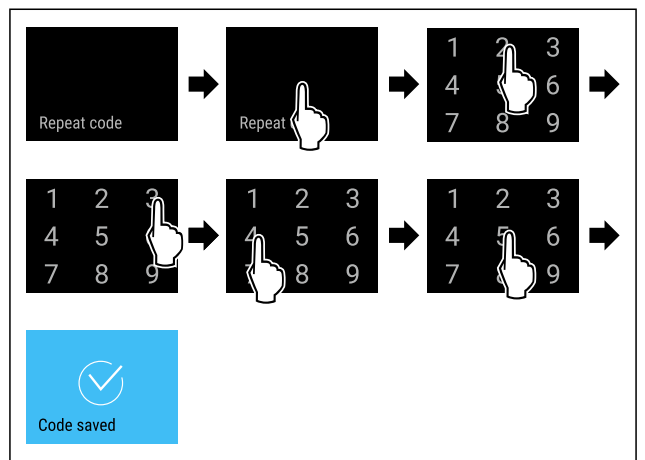

Fig. 107

- ▶ Carry out action steps according to the illustration.
- ▷ Confirmation of the new SmartLock code successful.
- ▷ The SmartLock code has been changed.

Resetting SmartLock code

SmartLock code forgotten or not known.

- ▶ Reset appliance to factory settings. (see 6.2.33 Resetting to factory settings)
- ▷ The appliance is reset to the original settings.
- ▷ The factory setting for the SmartLock code is: **1 1 1 1**



6.2.10 Remote control

When supplied, a factory PIN code is stored on the remote control. This opens every appliance with factory settings unchanged (see 6.2.33 Resetting to factory settings). This means multiple appliances can be opened and closed with just one remote control. Pairing generates an appliance-specific PIN code which can only open and close the appliance which is signed in. A factory reset restores the original functionality.

Note

The range of the remote control is approximately 15 m.

Application:

- Pairing remote control.
- Unpairing remote control.

Pairing remote control



Fig. 108

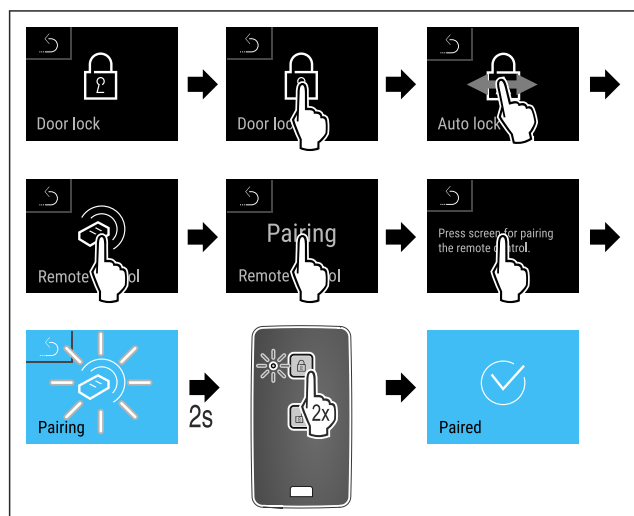

Fig. 109

- ▶ Carry out action steps according to the illustration.
- ▶ Press a button on the remote control twice.
- ▷ The status LED on the remote control flashes three times.
- ▷ The remote control is connected to the appliance.

Unpairing remote control



Fig. 110

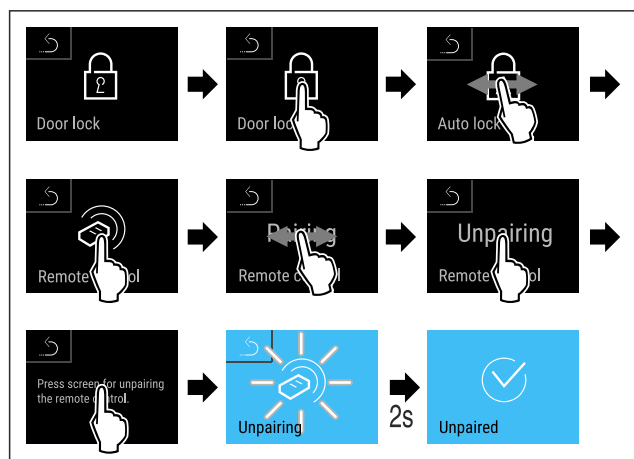

Fig. 111

- ▶ Carry out action steps according to the illustration.
- ▷ The remote control is disconnected from the appliance.

6.2.11 Maintenance interval reminder



Setting for the time interval after which a maintenance reminder is issued.

The following values can be set:

- 7 days
- 14 days
- 30 days

- 60 days
- 90 days
- 180 days
- 360 days
- 720 days
- 1080 days
- Off

Setting maintenance interval reminder

The following steps describe how the maintenance interval is set.

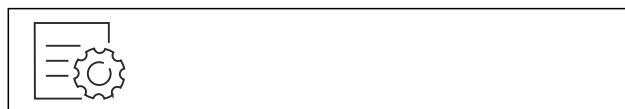

Fig. 112

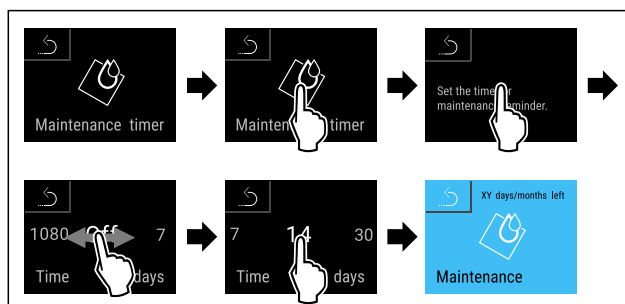

Fig. 113

- ▶ Carry out action steps according to the illustration.
- ▷ The time interval, after which the maintenance reminder is issued, is set.
- ▷ The remaining time is displayed.

6.2.12 Language



This setting allows the display language to be set.

Setting language



Fig. 114

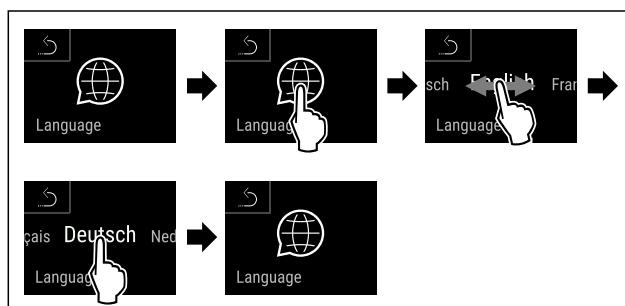

Fig. 115

- ▶ Carry out action steps according to the illustration.
- ▷ The selected language is set.

6.2.13 Date and time



This setting makes it possible to set the date and time.

Controls

Setting date and time



Fig. 116

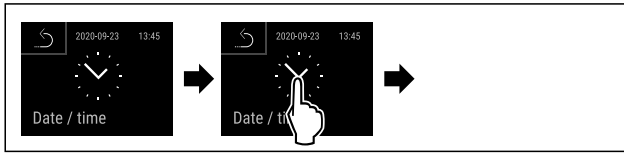

Fig. 117

► Carry out action steps according to the illustration.

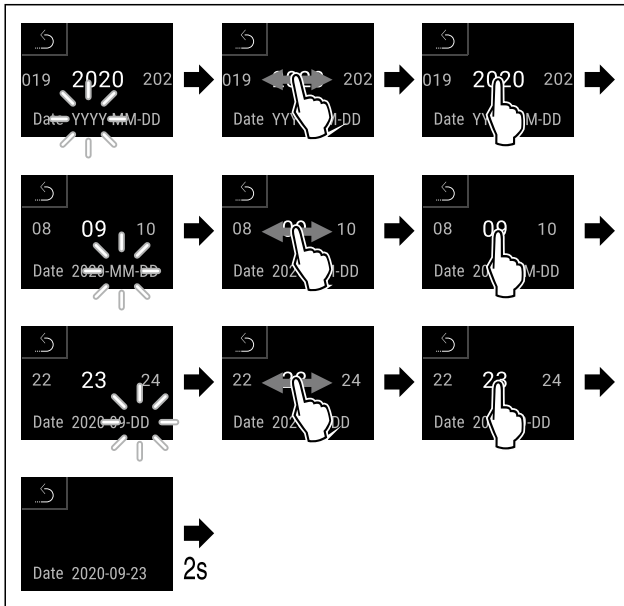

Fig. 118

► Carry out action steps according to the illustration.
▷ Date has been set.

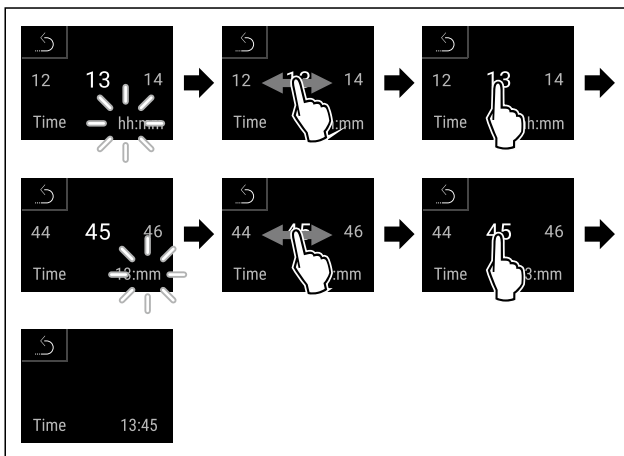

Fig. 119

► Carry out action steps according to the illustration.
▷ Time has been set.

6.2.14 Temperature unit



Use this function to set the temperature unit. You can set degrees Celsius or degrees Fahrenheit as the temperature unit.

Setting the temperature unit



Fig. 120

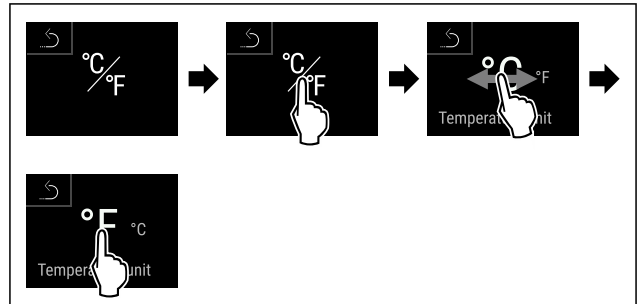

Fig. 121 Example illustration: Switch from degrees Celsius to degrees Fahrenheit.

► Carry out action steps according to the illustration.
▷ The temperature unit is set.

6.2.15 Display brightness



Use this function to set the display brightness in stages.

You can select the following brightness levels:

- 40 %
- 60 %
- 80 %
- 100 % (pre-setting)

Setting the brightness



Fig. 122

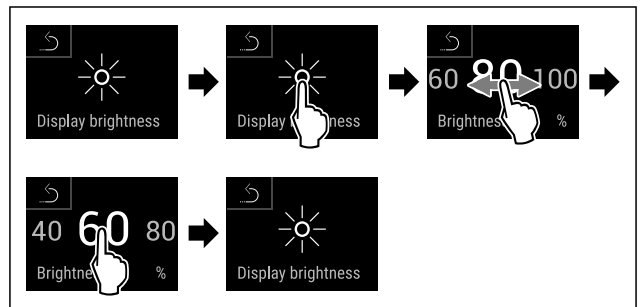

Fig. 123 Example illustration: Switch from 80 % to 60 %.

► Carry out action steps according to the illustration.
▷ The brightness is set.

6.2.16 Alarm Sound



This function enables all alarm sounds, such as door alarms, to be switched on and off.

Activating Alarm Sound



Fig. 124

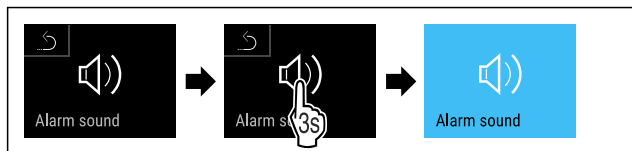

Fig. 125

- ▶ Carry out action steps according to the illustration.
- ▷ Alarm Sound is activated.

Deactivating Alarm Sound



Fig. 126

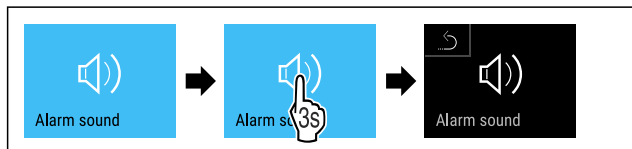
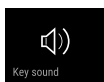

Fig. 127

- ▶ Carry out action steps according to the illustration.
- ▷ Alarm Sound is deactivated.

6.2.17 Key Sound



This function makes it possible to switch all button sounds, confirmation sounds, and the startup sound on and off.

Activating Key Sound



Fig. 128

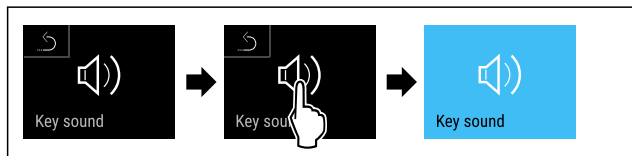

Fig. 129

- ▶ Carry out action steps according to the illustration.
- ▷ Key Sound is activated.

Deactivating Key Sound

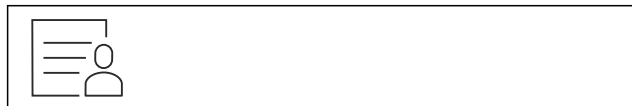

Fig. 130

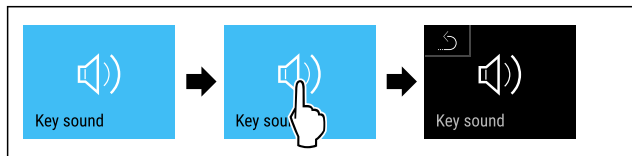

Fig. 131

- ▶ Carry out action steps according to the illustration.
- ▷ Key Sound is deactivated.

6.2.18 WiFi connection



Note

Liebherr SmartMonitoring Dashboard is not available in all countries. Check availability via the QR code by entering your model.

Note

Use of the Liebherr SmartMonitoring Dashboard at <https://smartmonitoring.liebherr.com> requires installation of a SmartModule and a commercial MyLiebherr account. When commissioning online you can register using the login data you have, or register again and create a company account.

This setting establishes a wireless connection between the appliance and the internet. The connection is controlled via the SmartModule. The appliance can be integrated via the browser-based [Liebherr SmartMonitoring Dashboard](#) and advanced options as well as customised methods relating to control, administration and monitoring can be used.

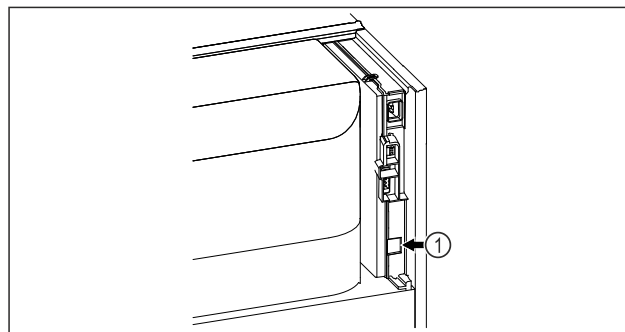

Fig. 132

Make sure that the following requirements are fulfilled:

- SmartModule Fig. 132 (1) is in use.

Establishing connection

You commission and set up your SmartModule online via the [Liebherr SmartMonitoring Dashboard](#) on your web-enabled device.

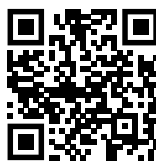

Fig. 133

- ▶ Open [Liebherr SmartMonitoring Dashboard](#). (see Fig. 133)
- On the refrigerator or freezer:



Fig. 134

Note

The settings menu access protection is activated. (see 6.2.8 Settings menu access protection)

- ▶ Enter the chosen PIN code. The settings menu opens.



Controls

Fig. 135

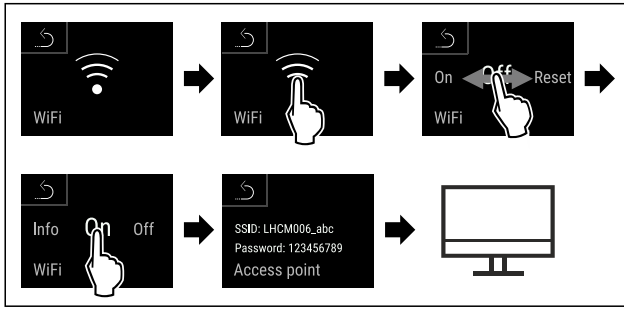

Fig. 136

- ▶ Carry out action steps according to the illustration.
- ▶ Continue the set-up procedure on your web-enabled device: [Liebherr SmartMonitoring Dashboard](#)

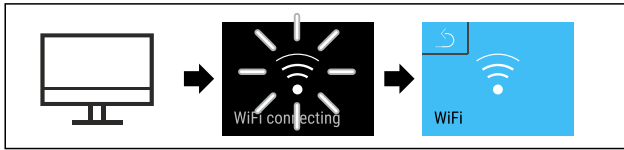

Fig. 137

- ▶ Carry out action steps according to the illustration.
- ▷ Connection is established: WiFi connecting appears. The symbol flashes.
- ▶ Follow the [Liebherr SmartMonitoring Dashboard](#) instructions.
- ▷ Connection is established.

Disconnecting



Fig. 138

Note

- The settings menu access protection is activated. (see 6.2.8 Settings menu access protection)
- ▶ Enter the chosen PIN code. The settings menu opens.



Fig. 139

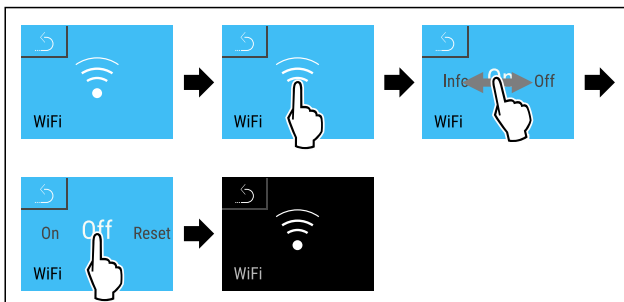

Fig. 140

- ▶ Carry out action steps according to the illustration.
- ▷ There is no connection.

Resetting connection



Fig. 141

Note

- The settings menu access protection is activated. (see 6.2.8 Settings menu access protection)
- ▶ Enter the chosen PIN code. The settings menu opens.



Fig. 142

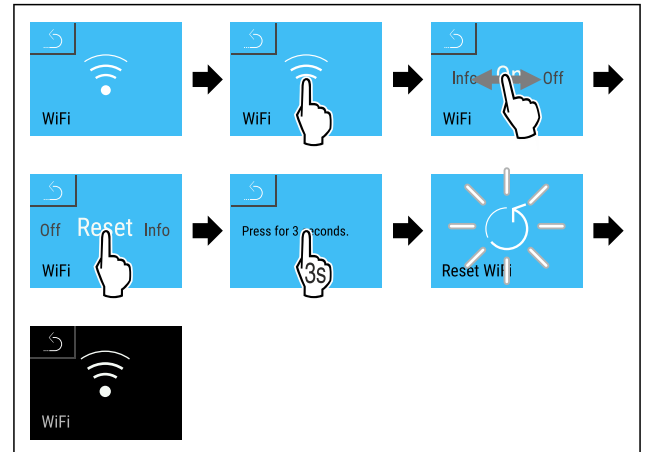
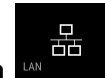

Fig. 143

- ▶ Carry out action steps according to the illustration.
- ▷ The WiFi settings are restored to the factory settings.



6.2.19 LAN connection

Note

Liebherr SmartMonitoring Dashboard is not available in all countries. Check availability via the QR code by entering your model.

Note

Use of the Liebherr SmartMonitoring Dashboard at <https://smartmonitoring.liebherr.com> requires installation of a SmartModule and a commercial MyLiebherr account. When commissioning online you can register using the login data you have, or register again and create a company account.

This setting establishes a wired connection between the appliance and the internet. The connection is controlled via the SmartModule. The appliance can be integrated via the browser-based [Liebherr SmartMonitoring Dashboard](#) and advanced options as well as customised methods relating to control, administration and monitoring can be used.

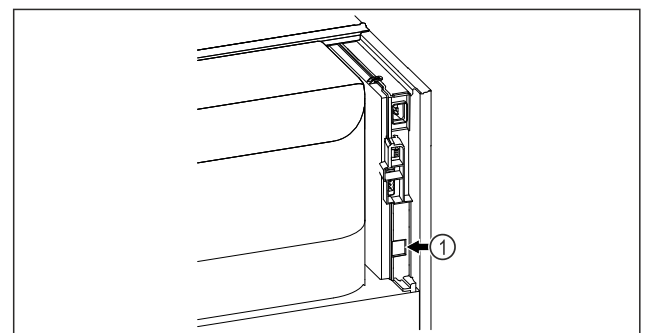

Fig. 144

Make sure that the following requirements are fulfilled:

- ❑ SmartModule Fig. 144 (1) is in use.
- ❑ A network cable is connected.

Establishing connection

You commission and set up your SmartModule online via the [Liebherr SmartMonitoring Dashboard](#) on your web-enabled device.

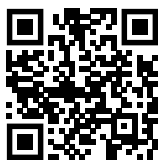

Fig. 145

- ▶ Open [Liebherr SmartMonitoring Dashboard](#). (see Fig. 145)

On the refrigerator or freezer:



Fig. 146

Note

The settings menu access protection is activated. (see 6.2.8 Settings menu access protection)

- ▶ Enter the chosen PIN code. The settings menu opens.

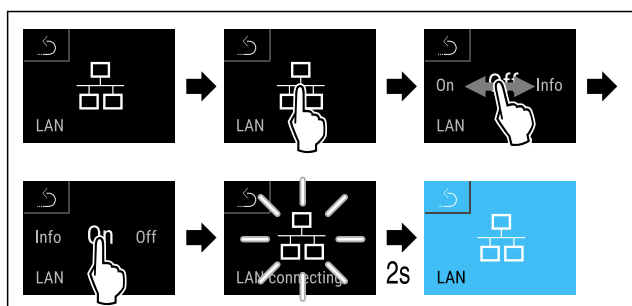

Fig. 147

- ▶ Carry out action steps according to the illustration.
- ▷ Connection is established: LAN connecting appears. The symbol flashes.
- ▶ Follow the [Liebherr SmartMonitoring Dashboard](#) instructions.
- ▷ Connection is established.

Disconnecting



Fig. 148

Note

The settings menu access protection is activated. (see 6.2.8 Settings menu access protection)

- ▶ Enter the chosen PIN code. The settings menu opens.

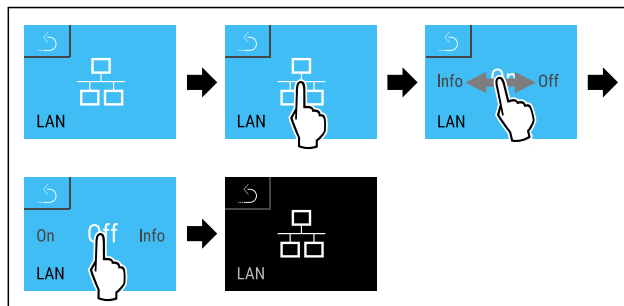

Fig. 149

- ▶ Carry out action steps according to the illustration.
- ▷ There is no connection.

6.2.20 Device information

Use this function to indicate the model name, index, serial number and service number of your device. You will need the device information when you contact customer service. (see 9.3 Customer Service)

This function also opens the Advanced menu. (see 3 Functionality of the Touch & Swipe display)

Indicating the device information



Fig. 150



Fig. 151

- ▶ Carry out action steps according to the illustration.
- ▷ Display indicates device information.

6.2.21 Operating hours

The display shows the appliance operating hours.

Displaying operating hours



Fig. 152

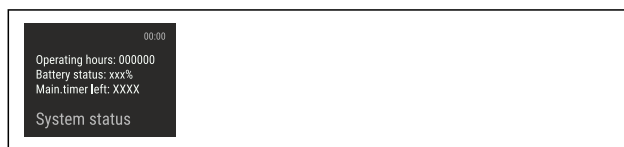

Fig. 153

- ▷ The operating hours appear.

6.2.22 Software

Use this function to indicate the software version of your device.

Controls

Indicating the software version



Fig. 154

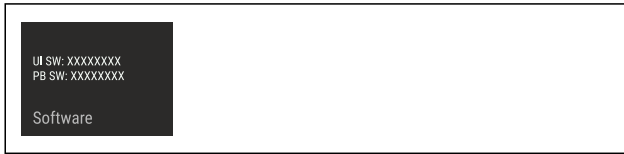

Fig. 155

- ▶ Carry out action steps according to the illustration.
- ▷ Display indicates software version.

6.2.23 Defrosting



The appliance defrosts automatically in normal mode.

Application:

- If there is excessive ice in the interior, the defrosting function can be started manually.

Manually starting automatic defrosting



Fig. 156

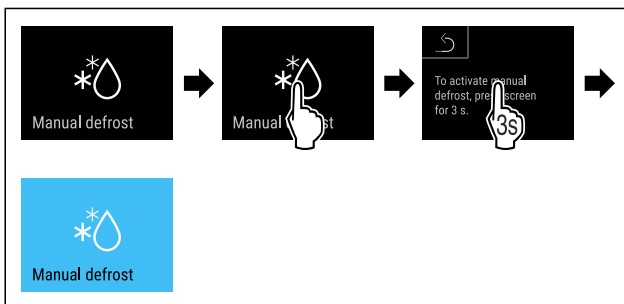

Fig. 157

- ▶ Carry out action steps according to the illustration.
- ▷ Automatic defrosting has been started. The appliance automatically switches back to normal mode once defrosting has finished.

Note

If there is still ice in the interior after starting automatic defrosting several times, defrost the appliance manually. (see 8.2 Defrosting appliance)

Cancelling manually started defrosting



Fig. 158

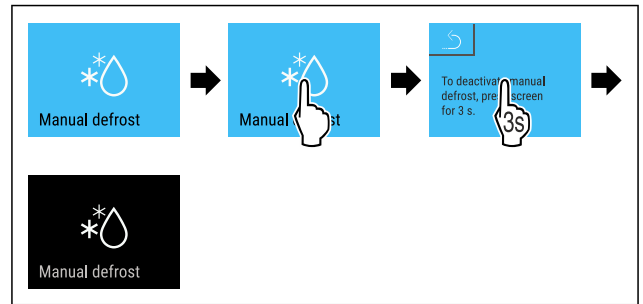

Fig. 159

- ▶ Carry out action steps according to the illustration.
- ▷ Manually started defrosting is cancelled. The appliance automatically switches back to normal mode.



Defrosting info

This setting adjusts the display during an automatic defrosting process.

The following display variants are available:

- **Def 1:** The temperature display is not updated and shows the last temperature before the automatic defrosting process started.
- **Def 2:** “Automatic defrosting” icon is indicated on the status display. The temperature display is continuously updated and shows the actual temperature.
- **Def 3:** The temperature display is continuously updated and shows the actual temperature.
- **Def 4:** “Automatic defrosting” icon is indicated on the status display. The temperature display is not updated and shows the last temperature before the automatic defrosting process started.



Fig. 160 “Automatic defrosting process” symbol



Fig. 161

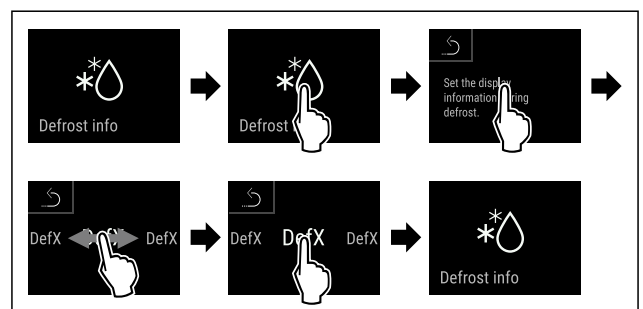

Fig. 162

- ▶ Carry out action steps according to the illustration.
- ▷ The desired display variant has been selected.



6.2.24 Data download / Datalogging

The appliance automatically records the entire temperature history of various sensors as well as alarm and service messages. The recording starts automatically after the appliance is switched on and records at one minute intervals. The data for the past 5 years is stored and can be downloaded onto a USB stick at any time.

The following data sets can be selected for download:

- Temperatures
- Alarms
- Service messages
- All

The selected data sets are stored in unencrypted format as text files over the entire recording period; these files have the extension „.log“.

Data download on USB stick

Note

Only USB memory sticks may be connected to the USB interface. USB hard drives are not detected.

Note

Do not remove the USB storage stick during the download procedure.

Make sure that the following requirements are fulfilled:

- USB 2.0 storage stick, FAT32 formatted.
- USB stick is connected.



Fig. 163

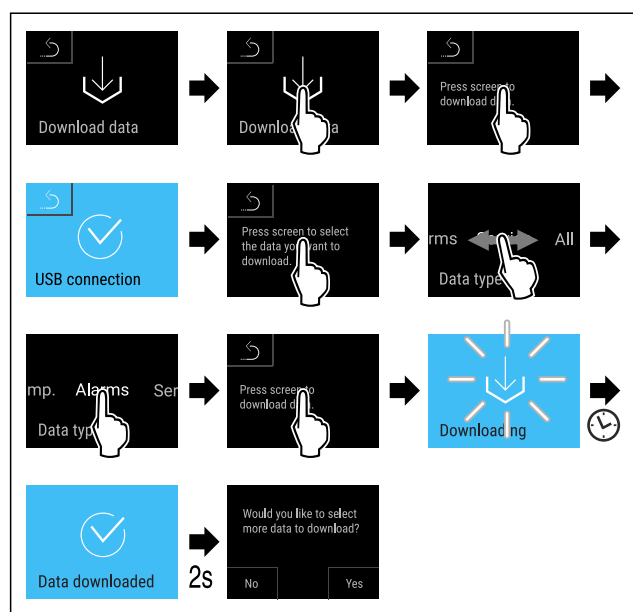

Fig. 164

- ▶ Carry out action steps according to the illustration.
- ▷ Successful data download on USB stick.
- ▷ It is possible to select and download further data sets.

6.2.25 Sensor calibration



The sensor calibration is used to realign differences between the displayed temperature and the actual temperature in the appliance.

Setting range for C sensor (control sensor): +/- 3 Kelvin in 0.1 Kelvin increments.

Setting range for P sensor (product sensor): +/- 9.9 Kelvin in 0.1 Kelvin increments

Calibrating sensor

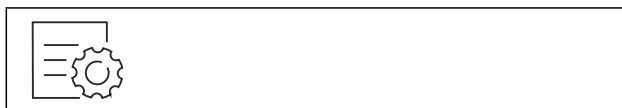

Fig. 165

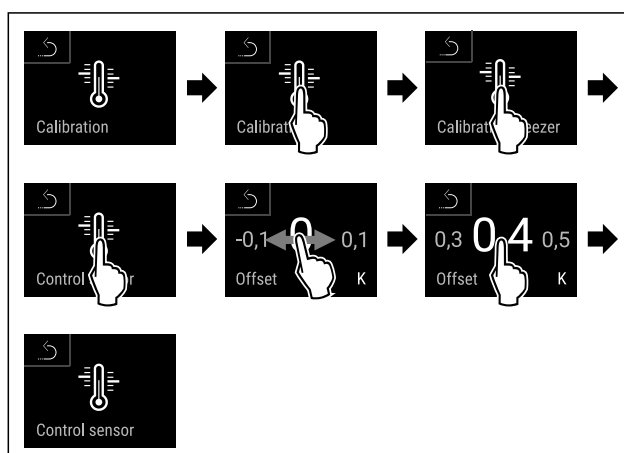

Fig. 166

- ▶ Carry out action steps according to the illustration.
- ▷ C sensor has been calibrated.

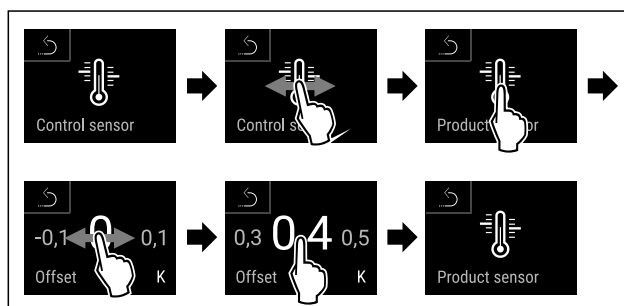

Fig. 167

- ▶ Carry out action steps according to the illustration.
- ▷ P sensor has been calibrated.
- ▷ Sensor calibration has been completed.

Note

The calibrated temperature is indicated on the display within two hours.

6.2.26 Temperature alarm



The temperature alarm is triggered as soon as the interior temperature differs from the adjustable temperature range and any set delay time has elapsed.

The following values can be set:

- Lower temperature limit in 0.1 °C increments
- Upper temperature limit in 0.1 °C increments
- Alarm delay time from 0 to 60 minutes (setting "0" means no alarm repetition at the alarm relay.)
- Alarm repetition frequency of between 0 and 30 minutes

Setting temperature alarm



Fig. 168



Fig. 169

- ▶ Carry out action steps according to the illustration.



Fig. 170

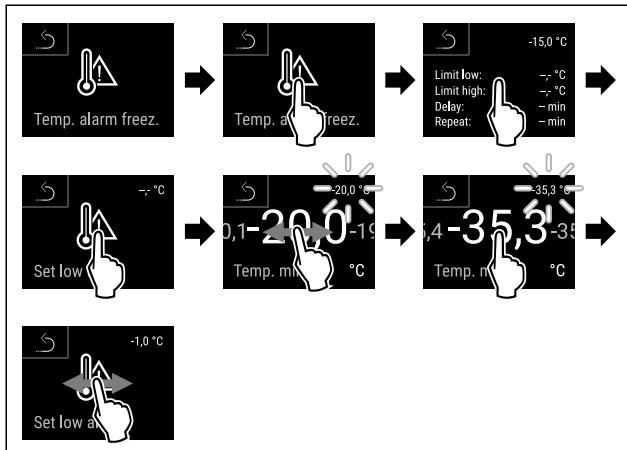

Fig. 171

- ▶ Carry out action steps according to the illustration.
- ▷ Lower temperature limit has been set.

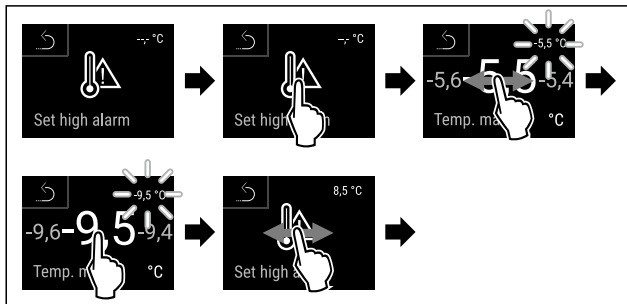

Fig. 172

- ▶ Carry out action steps according to the illustration.
- ▷ Upper temperature limit has been set.

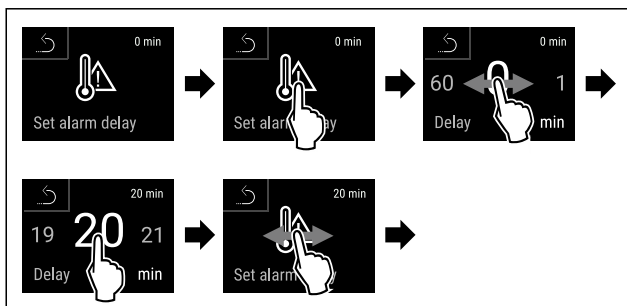

Fig. 173

- ▶ Carry out action steps according to the illustration.
- ▷ Alarm delay time has been set.

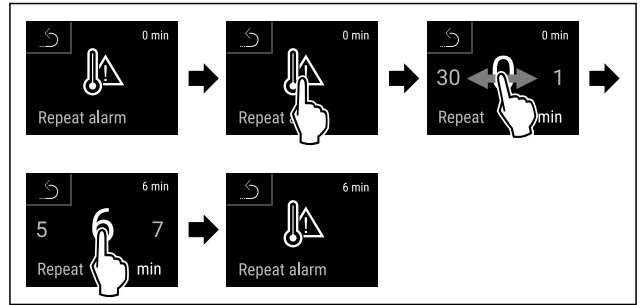

Fig. 174

- ▶ Carry out action steps according to the illustration.
- ▷ Alarm repetition interval has been set.
- ▷ Temperature alarm has been set.

Displaying set temperature alarm values



Fig. 175



Fig. 176

- ▶ Carry out action steps according to the illustration.



Fig. 177



Fig. 178

- ▶ Carry out action steps according to the illustration.
- ▷ Set temperature alarm values are displayed.

6.2.27 Door alarm



Use this function to activate or deactivate the door alarm. The door alarm sounds if the door is open for too long. The door alarm is activated on delivery. You can set how long the door may be open before the door alarm sounds.

The following values can be set:

- 15 seconds
- 30 seconds
- 60 seconds
- 90 seconds
- 120 seconds
- 150 seconds
- 180 seconds
- Off

Setting the door alarm



Fig. 179

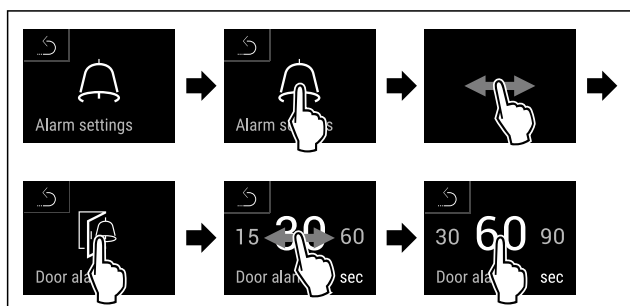

Fig. 181 Example illustration: Switch door alarm from 30 seconds to 60 seconds.

- ▶ Carry out action steps according to the illustration.
- ▷ The door alarm is set.

Deactivating the door alarm



Fig. 182

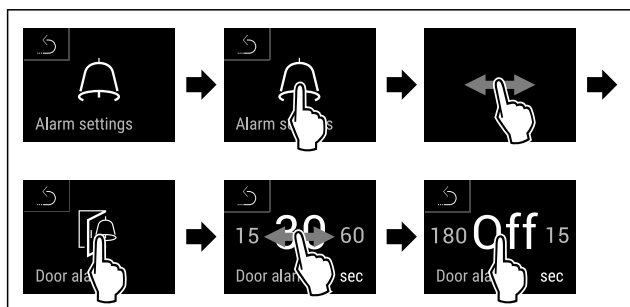

Fig. 183

- ▶ Carry out action steps according to the illustration.
- ▷ The door alarm is deactivated.

6.2.28 Light alarm



This setting allows the visual alarm messages in the display to also be emphasised by flashing appliance lighting.

Activating light alarm



Fig. 184

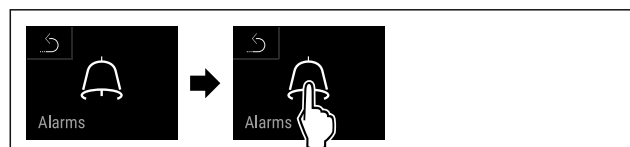

Fig. 185

- ▶ Carry out action steps according to the illustration.



Fig. 186

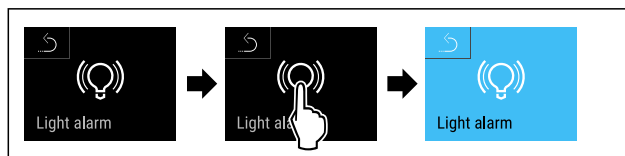

Fig. 187

- ▶ Carry out action steps according to the illustration.
- ▷ The light alarm is activated.

Deactivating light alarm

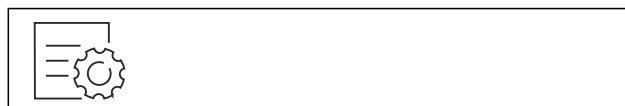

Fig. 188

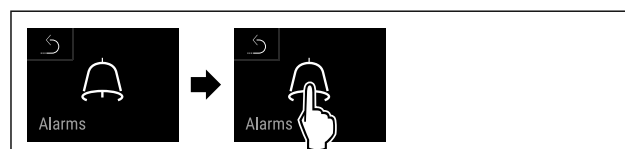

Fig. 189

- ▶ Carry out action steps according to the illustration.



Fig. 190



Fig. 191

- ▶ Carry out action steps according to the illustration.
- ▷ The light alarm is deactivated.

6.2.29 Alarm simulation



This setting makes it possible to simulate a change in the appliance temperature to check the function of any safety devices that may be connected.

Starting alarm simulation



Fig. 192



Controls

Fig. 193

- ▶ Carry out action steps according to the illustration.

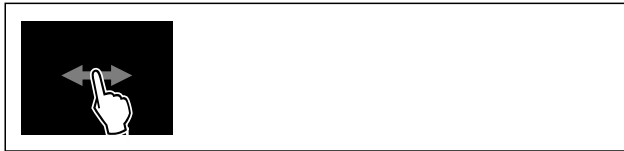

Fig. 194

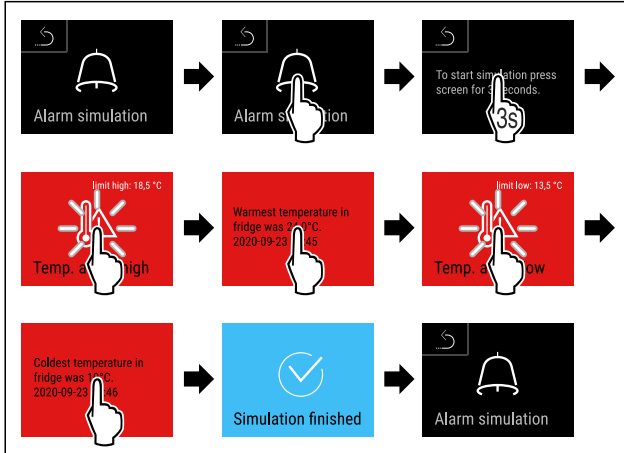
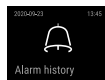

Fig. 195

- ▶ Carry out action steps according to the illustration.
- ▷ The simulation has been performed.
- ▷ Connected safety devices should have triggered.



6.2.30 Alarm log

This setting makes it possible to query and delete the last 10 alarms that have occurred on the device.

The following is displayed:

- Current date and time
- Active alarms (red).
- Past alarms, which have not yet been queried, are shown as **unconfirmed (red)**. Confirmation is given by swiping to the next error.
- Alarms, which have been queried, are shown as **confirmed**.
- Deletion of all alarms (including active and unconfirmed alarms).

Displaying alarm log and deleting an alarm



Fig. 196

- or-
- ▶ Via the display symbol at the bottom edge of the status display.

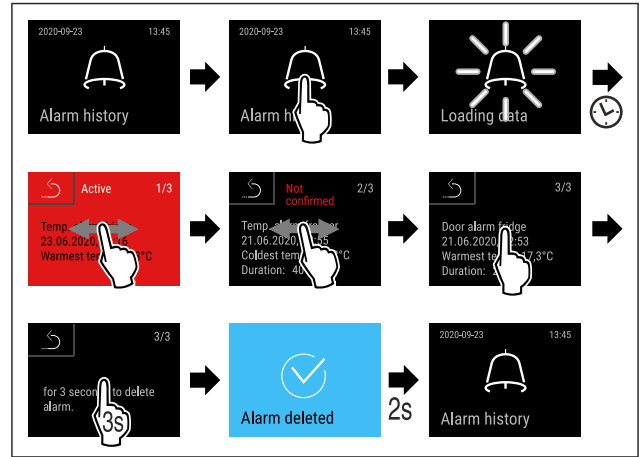

Fig. 197

- ▶ Carry out action steps according to the illustration.
- ▷ The querying and deletion of an alarm has been performed.

Displaying alarm log and deleting all alarms



Fig. 198

- or-
- ▶ Via the display symbol at the bottom edge of the status display.

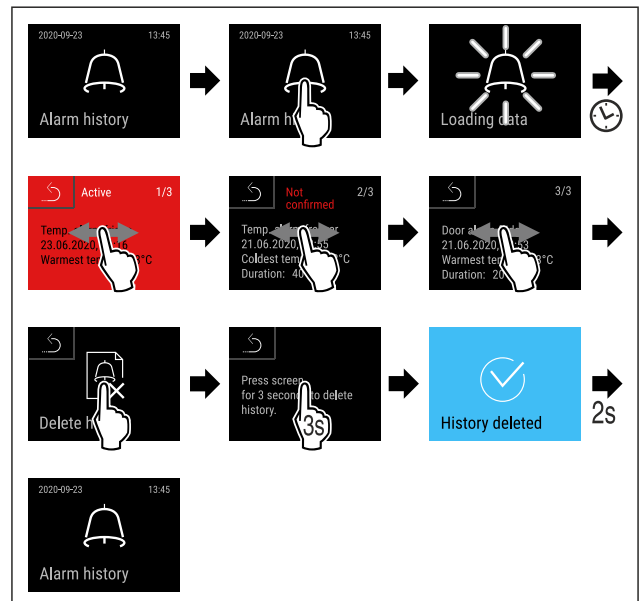
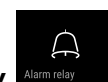

Fig. 199

- ▶ Carry out action steps according to the illustration.
- ▷ The querying and deletion of all alarms has been performed.



6.2.31 Alarm relay

This setting makes it possible to relay one or more alarms to an external alarm receiver connected to the appliance.

The following settings can be selected:

- Alarm type:
 - Door alarm

- Temperature alarm
- Door alarm and temperature alarm
- All
- Confirm:
 - **Yes:** The alarm is terminated at the appliance and the externally connected receiver.
 - **No:** The alarm is acknowledged at the appliance and remains active at the receiver until the error is rectified.
- Update (only visible if “Yes” is selected when confirming):
 - **Yes:** Alarm repeats.

Temperature alarm depending on the set time (see 6.2.26 Temperature alarm)
 (If the alarm delay time is set to “0”, the alarm relay will not repeat the alarm.)
Door alarm after 1 or 4 minutes * (see 6.2.27 Door alarm)

 - **No:** Alarm is continuously acknowledged.

Activating alarm relay

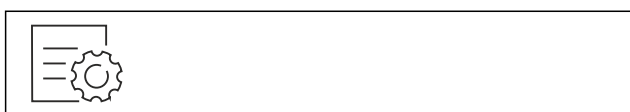

Fig. 200

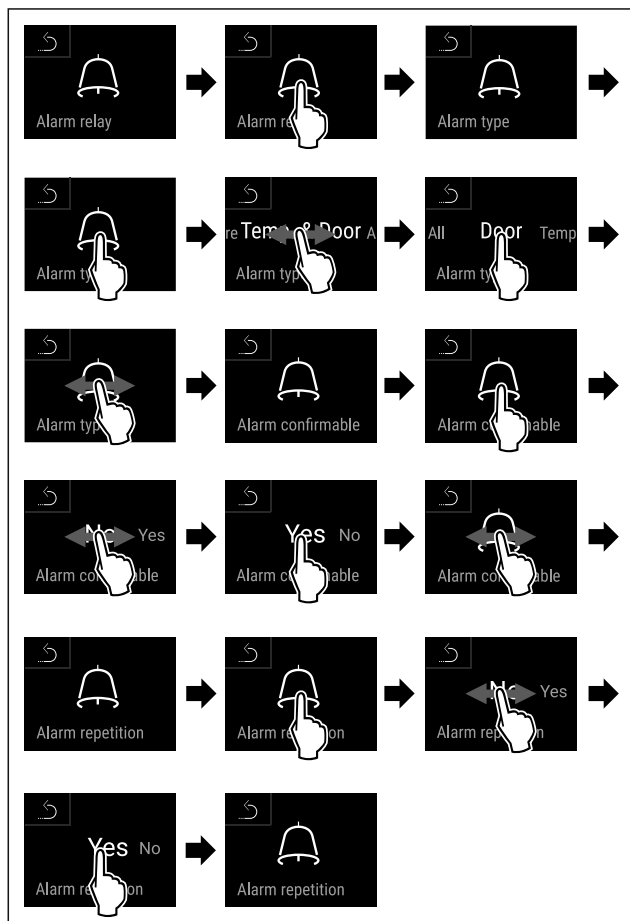
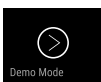

Fig. 201

- ▶ Carry out action steps according to the illustration.
- ▷ The alarm relay has been set.

6.2.32 Demo mode



Demo mode is a special feature for dealers who want to demonstrate appliance features. If you activate demo mode, all refrigeration functions are deactivated.

If you switch on your appliance and a “D” appears on the status display, demo mode is already activated.

If you activate and then deactivate demo mode, the appliance will be reset to factory defaults. (see 6.2.33 Resetting to factory settings)

Activating demo mode



Fig. 202

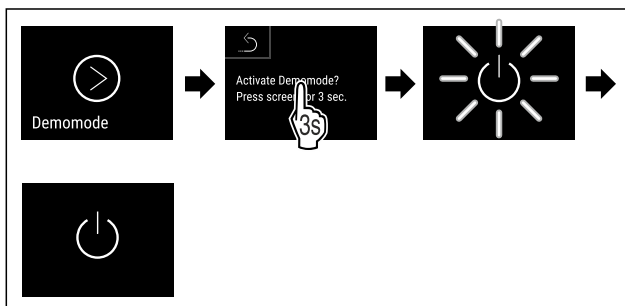

Fig. 203

- ▶ Carry out action steps according to the illustration.
- ▷ Demo mode is activated.
- ▷ Appliance is switched off.
- ▶ Switch on the appliance. (see 4.14 Switching on appliance (first use))
- ▷ “D” appears in the status display.

Deactivating demo mode



Fig. 204

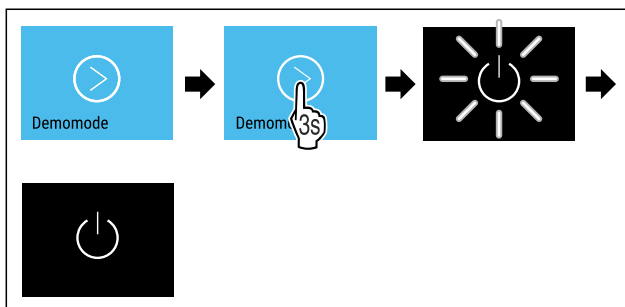

Fig. 205

- ▶ Carry out action steps according to the illustration.
- ▷ Demo mode is deactivated.
- ▷ Appliance is switched off.
- ▶ Switch on the appliance. (see 4.14 Switching on appliance (first use))
- ▷ Appliance is reset to factory settings.

6.2.33 Resetting to factory settings



Use this function to reset all settings to factory defaults. All settings you have made so far are reset to their original settings.

Performing a reset

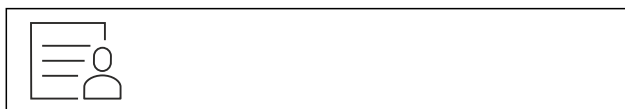

Fig. 206

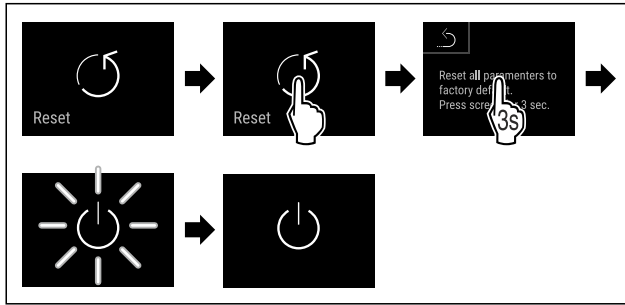

Fig. 207

- ▶ Carry out action steps according to the illustration.
- ▷ Device is reset.

▷ Device is switched off.

Note



To reset to factory settings in battery mode: Restart is only possible with mains voltage.







- ▶ Restart the device. (see 4.14 Switching on appliance (first use))

6.3 Message

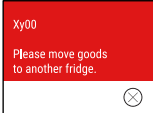

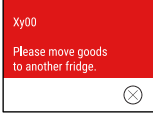
6.3.1 Warnings

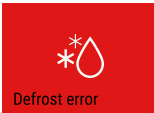
Warnings are issued by means of an acoustic signal and visually via a symbol on the display. The signal gets louder until the warning is acknowledged.

Message (red)	Cause	Remedy
 <p>Close the door</p> <p>Door open</p>	<p>This message appears if the door is open for too long.</p>	<p>Close the door.</p> <p>Tap briefly.</p> <p>Alarm is stopped.</p> <p>Note</p> <p>The time until the message appears can be set. (see 6.2.27 Door alarm)</p>
 <p>Temperature alarm</p> <p>Temperature alarm</p>	<p>This message appears if the temperature does not match the set temperature. Reasons for differences in temperature can be:</p> <p>Warm produce for cooling has been placed inside.</p> <p>Too much warm air has got in while you were sorting out the freezer or removing items.</p> <p>The power was cut off for a prolonged period.</p>	<p>Tap briefly.</p> <p>Information about errors and appliance status are displayed.</p> <p>Tap briefly.</p> <p>Warmest/coldest temperature, date and time are displayed.</p> <p>Tap briefly.</p> <p>The status screen is displayed.</p> <p>The current temperature and the alarm symbol flash red until the set temperature is reached.</p> <p>Check the quality of the refrigerated goods.</p>



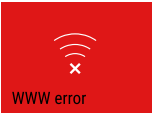

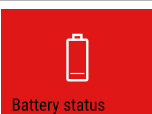
Message (red)	Cause	Remedy
 <p>Device failure</p> <p>Error</p>	<p>The appliance is faulty, there is an appliance error or a component of the appliance has a fault.</p>	<p>Store the cooled produce elsewhere.</p> <p>Tap briefly.</p> <p>The error code (e.g. BT021) is displayed.</p> <p>Tap briefly.</p> <p>A further error code is displayed if there is one</p> <p>or</p> <p>Status screen is displayed with flashing error symbol.</p> <p>Swiping or tapping the display will show the error code(s) again.</p> <p>Make a note of error code(s) and contact Customer Service. (see 9.3 Customer Service)</p>  
	<p>The message indicates unscheduled defrosting behaviour. For example, the evaporator could ice up to an unusual extent due to prolonged door openings and the defrosting time may no longer be sufficient.</p>	<p>Tap briefly.</p> <p>DEFR.MAX is displayed.</p> <p>Tap briefly.</p> <p>Status screen is displayed with flashing error symbol.</p> <p>Swiping or tapping the display will show the message again.</p> <p>Store the cooled produce elsewhere and defrost the appliance by hand. Alternatively, defrosting can be started manually. (see 6.2.23 Defrosting)</p> <p>Pressing and holding the flashing error icon will make it disappear. If it appears again, contact Customer Service. (see 9.3 Customer Service)</p>  
 <p>Power failure</p> <p>Power cut</p>	<p>The message appears following an interruption to the electricity supply.</p> <p>The operating panel continues running in battery mode. All functions remain active except for refrigeration and lighting.</p>	<p>Tap briefly.</p> <p>Battery's state of charge, information about errors and appliance status are displayed</p> <p>Tap briefly.</p> <p>Highest temperature, time period and number of electricity supply interruptions are displayed.</p> <p>Tap briefly.</p> <p>The status screen is displayed.</p> <p>The current temperature and the alarm symbol flash red until the set temperature is reached.</p> <p>Check the quality of the refrigerated goods.</p>
 <p>Defrost error</p> <p>Defrost error</p>	<p>The automatic defrosting is not working properly. The previous five defrost cycles were not successful.</p>	<p>Press briefly.</p> <p>Alarm is stopped.</p> <p>Contact Customer Service. (see 9.3 Customer Service)</p>
 <p>WiFi error</p> <p>WiFi error</p>	<p>Wi-Fi connection is interrupted.</p>	<p>Check connection.</p> <p>Press briefly.</p> <p>Alarm is stopped.</p>

Features

Message (red)	Cause	Remedy
 <p>WWW error</p> <p>WWW error, WiFi</p>	This message appears if there is no internet connection via WiFi.	Check connection. Press briefly. Alarm is stopped.
 <p>LAN error</p> <p>LAN error</p>	LAN connection is interrupted.	Check connection and network cable. Press briefly. Alarm is stopped.
 <p>WWW error</p> <p>WWW error, LAN</p>	This message appears if there is no internet connection via LAN.	Check connection. Press briefly. Alarm is stopped.
 <p>Battery status</p> <p>Battery error</p>	Low appliance battery level (max. 20% remaining).	Reconnect the appliance to a power supply and check whether the battery charge level has increased after 12 hours. Otherwise contact Customer Service (see 9.3 Customer Service) or replace the battery. (see 8.4 Replacing appliance battery) Press briefly. Alarm is stopped.

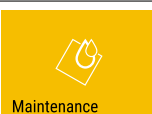
6.3.2 Reminders

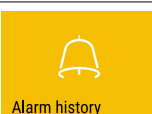
Reminders appear when you are being asked to do something. They are issued by means of an acoustic signal and visually via a symbol on the display. Acknowledge the message by pressing the confirmation button.

Message (yellow)	Cause	Remedy
 <p>Maintenance</p> <p>Maintenance reminder</p>	The message appears when the timer for the set maintenance interval has expired.	Press briefly. Reminder is closed. Note The maintenance interval can be set (see 6.2.11 Maintenance interval reminder).
 <p>Min./max. memory</p> <p>Recording reminder</p>	The message appears when the temperature recording memory (999 hours) is full.	Press briefly. Reminder is closed. The oldest data is overwritten. Note The temperature recording can be reset. (see 6.2.4 Temperature recording)
 <p>Alarm history</p> <p>Alarm log</p>	The message appears if there are more than 10 unconfirmed alarm messages.	Press briefly. Check messages. Reminder is closed.
 <p>Manually opened</p> <p>Manually opened</p>	This message appears if a door which has been locked electronically is manually opened.	Close the door. Press briefly. Reminder is closed.

7 Features

7.1 Safety lock

The appliance is fitted with an electronic lock.

Possible functions:

- Locking and unlocking the door lock using the door code. (see 6.2.6 Door lock)

- Activating and deactivating automatic locking of the door. (see 6.2.6 Door lock)
- Operation via remote control. (see 6.2.10 Remote control)

7.1.1 Emergency unlocking

In the event of a power failure, the door can be opened using the emergency release key.

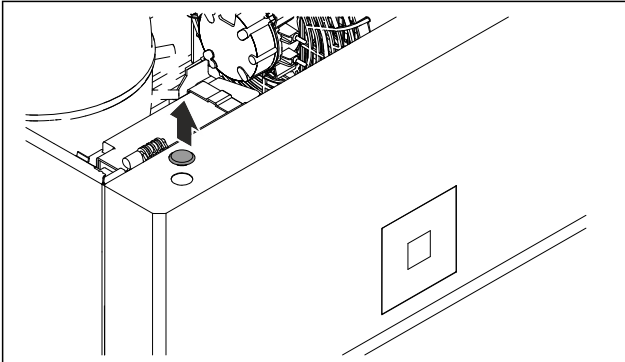

Fig. 208

- ▶ Remove cover.

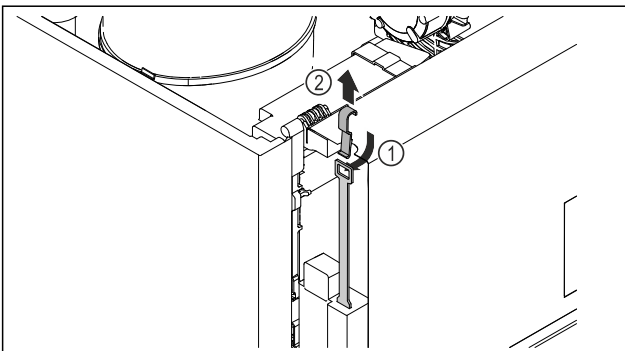

Fig. 209

- ▶ Insert the emergency release key from above Fig. 209 (1), hook it onto the lock and pull it upwards Fig. 209 (2).
- ▷ The lock is unlocked. The door can be opened.

7.2 Remote control

The remote control allows the door lock to be engaged and unlocked remotely.

It must be linked to the appliance before use. (see 6.2.10 Remote control)

The battery can be replaced. (see 8.4 Replacing appliance battery)

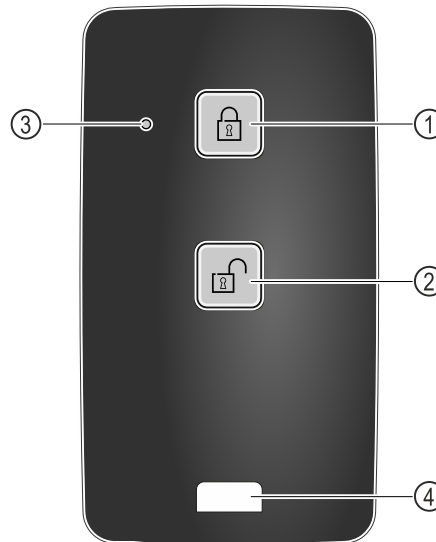

Fig. 210

- (1) Engage lock
- (2) Unlock lock
- (3) Status LED
- (4) Fastening eyelet

7.2.1 Using remote control

- ▶ Press button Fig. 210 (1) on the remote control.
 - ▷ The lock is engaged. The door cannot be opened.
- ▶ Press button Fig. 210 (2) on the remote control.
 - ▷ The lock is unlocked. The door can be opened.
- ▶ Status LED Fig. 210 (3) provides a visual acknowledgement when you press the button.
- ▶ Eyelet Fig. 210 (4) for attaching remote control, for example, to a key ring.

7.3 Sensors

The appliance can be equipped with the following sensors for temperature monitoring:

- C sensor
- P sensor

7.3.1 C sensor (control sensor)

The C sensor is permanently installed and regulates the interior temperature of the appliance. You can calibrate the C sensor if necessary. (see 6.2.25 Sensor calibration)

7.3.2 P sensor (reference sensor)

The P sensor is permanently installed in the interior, in order to record and monitor the temperature in this location specifically. If the set temperature is exceeded in this location, the sensor triggers an alarm. You can calibrate the P sensor if necessary. (see 6.2.25 Sensor calibration)

7.4 Sensor info



This function makes it possible to choose between C sensor or P sensor.

Make sure that the following requirement is met:

- P sensor is connected to the appliance. (see 7.5 Interfaces)

Features

7.4.1 Selecting C sensor



Fig. 211

- Swipe left or right until corresponding function is displayed.

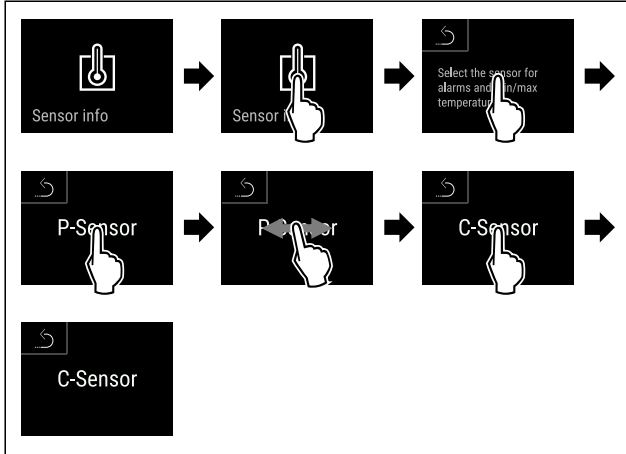

Fig. 212

- Carry out action steps according to the illustration.
- ▷ C sensor has been selected.

7.4.2 Selecting P sensor



Fig. 213

- Swipe left or right until corresponding function is displayed.

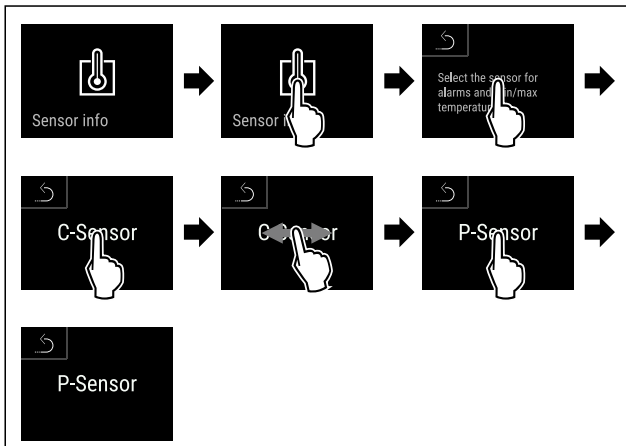

Fig. 214

- Carry out action steps according to the illustration.
- ▷ P sensor has been selected.

7.5 Interfaces

There are various connection options on the back of the appliance.

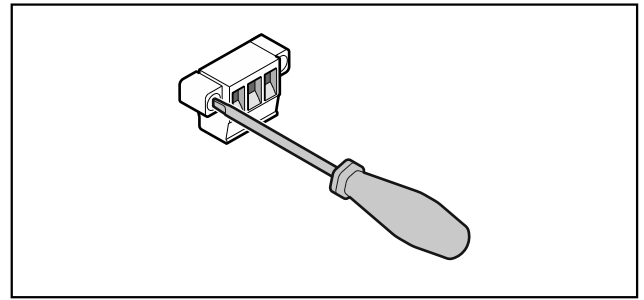

Fig. 215

Note

Screws secure the plugs. To enable disconnection of the plugs, loosen the screws on the left and right.

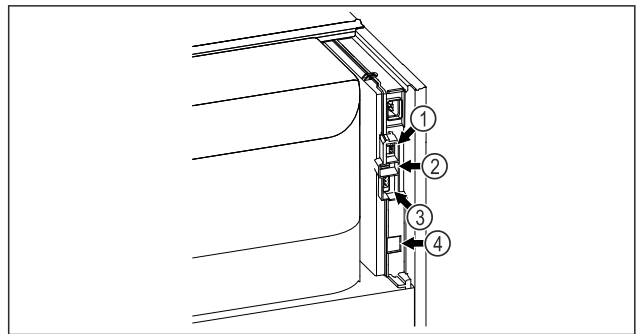

Fig. 216

- (1) Connection for P sensor
- (2) USB interface
- (3) Potential-free alarm output
- (4) LAN interface

7.5.1 Potential-free alarm output



WARNING

Risk of injury due to electric shock!

- The appliance may only be connected to an external alarm device by trained specialist personnel.

These three contacts can be used to connect a visual or an acoustic alarm device. The connection is designed for a maximum of **30 V (DC) - 8 A** from a safety low voltage source SELV (**minimum current 150 mA**).

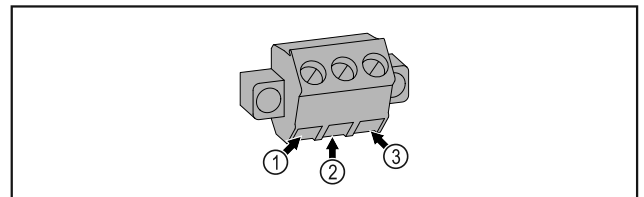

Fig. 217

- (1) NO (normally open)
Connection for indicator lamp, which is active in normal operation or when the appliance is switched off.
- (2) COM (common)
External voltage source
- (3) NC (normally closed)
Connection for alarm lamp or audible alarms, which is active when an alarm is triggered or there is a lack of power supply.

7.5.2 Connection for P sensor

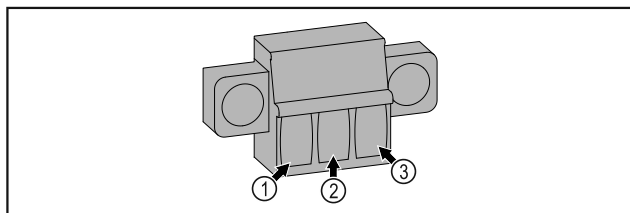

Fig. 218

- (1)** IN+ (measuring line +) **(3)** FORCE (supply +)
(2) IN- (common return line -)



WARNING

Short-circuit hazard due to live parts!
 Electric shock or damage to the electronics.

- ▶ **Switch off the appliance.**
- ▶ Pull out mains plug or switch off fuse.

Note

A maintenance reminder function can be activated. (see 6.2.11 Maintenance interval reminder)

Note

We recommend creating a maintenance log in which all work (repairs, checks) performed is documented.

Note

Liebherr recommends yearly maintenance. For an individual offer, please contact Customer Service (see 9.3 Customer Service) .

8 Maintenance

8.1 Maintenance schedule

Maintenance work is to be performed at regular intervals to ensure proper appliance function.



CAUTION

Danger of injury and damage due to unprofessional maintenance work!

Personal injury and material damage.

- ▶ Maintenance work may only be performed by trained specialist personnel.

Component	Activity	Maintenance interval
Sheet metal parts	Check for damage and corrosion. Replace damaged parts: (see 9.3 Customer Service)	Yearly
Door, hinges	Check alignment (see 4.12 Aligning the door) , ease of movement, and tight fit.	Yearly
Lock, door handle *	Check for ease of movement and tight fit.	Yearly
Door seal	Check for damage, wear, and tight fit. A replacement door seal is available via Customer Service (see 9.3 Customer Service) .	Yearly
Sensor	Calibrate sensor. (see 6.2.25 Sensor calibration)	Yearly
Sensor feedthrough	Check that the sealing compound is intact.	Yearly
Battery	Replace appliance battery. A replacement battery is available from customer service. (see 8.4 Replacing appliance battery)	5 to 10 years
Surfaces	Cleaning (see 8.3 Cleaning the appliance)	Recommendation: monthly or as required/specified at installation location
Surfaces	Disinfection	Recommendation: monthly or as required/specified at installation location
Installation location, appliance	Decontamination The appliance is suitable for room decontamination with hydrogen peroxide H ₂ O ₂ . In this context, the values of the following application specifications must not be exceeded: Concentration: maximum 250 ppm. Humidity: maximum 85%. Maximum permissible room temperature as per climate class. (see 1.4 Range of use of appliance)	Recommendation: as required/specified at installation location, maximum 2x per year
Fan air slots	Cleaning	Yearly

Maintenance

Component	Activity	Maintenance interval
Alarm relay Sensor	Check plug connections for tight fit.	Yearly
Mains cable	Check for damage.	Yearly or if there is a change of location
Tilt angle	Check for proper function and tight fit.	Yearly or if there is a change of location
Adjusting feet/castors	Check for proper function, damage, and tight fit. Replace damaged parts. (see 9.3 Customer Service)	Yearly

8.2 Defrosting appliance



WARNING

Improper defrosting of the appliance!
Injuries and damage.

- ▶ Do not use mechanical equipment or other methods to speed up the defrosting process other than those recommended by the manufacturer.
- ▶ Do not use electrical heating or steam-cleaning appliances, naked flames or defroster sprays to defrost.
- ▶ Do not use sharp objects to remove ice.

To maintain the functionality of the appliance, we recommend defrosting it when there is a high buildup of ice. Icing in the interior is determined by the location (e.g. high humidity), settings on the appliance and incorrect user behaviour.

Manual defrosting:

- ▶ Switch off appliance. (see 6.2.2 Switching appliance on and off)
- ▶ Pull out mains plug.
- ▶ Store refrigerated items elsewhere.
- ▶ Leave appliance door open during defrosting process.
- ▶ Absorb any remaining defrost water with a cloth and clean the appliance.

8.3 Cleaning the appliance

8.3.1 Preparing



WARNING

Short-circuit hazard due to live parts!
Electric shock or damage to the electronics.

- ▶ **Switch off the appliance.**
- ▶ Pull out mains plug or switch off fuse.



WARNING

Risk of fire

- ▶ Do not damage the refrigeration circuit.
- ▶ Empty the appliance.
- ▶ Pull out the mains plug.
- ▶ Observe the notes on transporting the appliance. (see 4.3 Transporting appliance)

8.3.2 Cleaning housing

NOTICE

Improper cleaning!

Damage to the appliance.

- ▶ Only use soft cleaning cloths and ph-neutral all-purpose cleaners.
- ▶ Do not use abrasive sponges or steel wool which may cause scratches.
- ▶ Do not use any sharp or abrasive cleaning agents, nor any that contain sand, chloride or acid.



WARNING

Risk of injury and damage as a result of hot steam!

Hot steam can lead to burns and can damage the surfaces.

- ▶ Do not use any steam cleaners!

NOTICE

Risk of damage due to short circuit.

- ▶ When cleaning the appliance, make sure no water gets into the electrical components.
- ▶ Wipe the housing down with soft, clean cloth. If very dirty, use lukewarm water with a neutral cleaner. Glass surfaces can also be cleaned with glass cleaner.
- ▶ Clean condenser coil each year. If the condenser coil is not cleaned, this significantly reduces the efficiency of the appliance.

8.3.3 Cleaning interior



WARNING

Short-circuit hazard due to live parts!
Electric shock or damage to the electronics.

- ▶ **Switch off the appliance.**
- ▶ Pull out mains plug or switch off fuse.



WARNING

Risk of injury and damage as a result of hot steam!

Hot steam can lead to burns and can damage the surfaces.

- ▶ Do not use any steam cleaners!

NOTICE

Improper cleaning!

Damage to the appliance.

- ▶ Only use soft cleaning cloths and ph-neutral all-purpose cleaners.
- ▶ Do not use abrasive sponges or steel wool which may cause scratches.
- ▶ Do not use any sharp or abrasive cleaning agents, nor any that contain sand, chloride or acid.

Note

Do not damage or remove the type plate on the inside of the appliance. The type plate is important for Customer Service. (see 9.3 Customer Service)

- ▶ Open the door.
- ▶ Empty the appliance.
- ▶ Clean interior and equipment parts with lukewarm water and a little detergent. Do not use any gritty or acidic cleaning agent or any chemical solvent.

8.3.4 After cleaning

- ▶ Wipe appliance and equipment parts dry.
- ▶ Connect and switch on appliance. Once the temperature is sufficiently cold: put in items for refrigeration goods.
- ▶ Repeat cleaning regularly.
- ▶ Clean and dust refrigerators with a heat exchanger (metal grille on the rear of the appliance) once per year.

8.4 Replacing appliance battery

In the event of a power failure, the appliance battery is used to record temperature history, alarm and service messages and to show the alarm messages on the display for approximately 12 hours. During initial commissioning, the battery may take up to 24 hours to charge and be in proper working order.

A replacement battery is available from customer service (see 9.3 Customer Service).

8.4.1 Replacing battery



WARNING

Short-circuit hazard due to live parts!
Electric shock or damage to the electronics.

- ▶ **Switch off the appliance.**
- ▶ Pull out mains plug or switch off fuse.

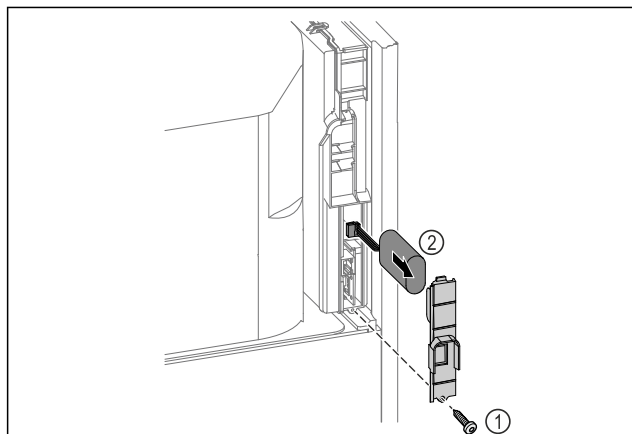

Fig. 219

- ▶ Unscrew screw and remove cover from the back of the appliance Fig. 219 (1).
- ▶ Disconnect and remove battery Fig. 219 (2).
- ▶ Install replacement battery.
- ▶ Close the cover and screw in the screw.
- ▶ Reconnect mains power cable.

Note

▶ The battery must be sent for separate waste treatment for batteries and must be disposed of in an expert and proper manner in accordance with the regulations and laws which apply locally. **Do not damage or short circuit the battery!**

8.5 Replacing the remote control batteries

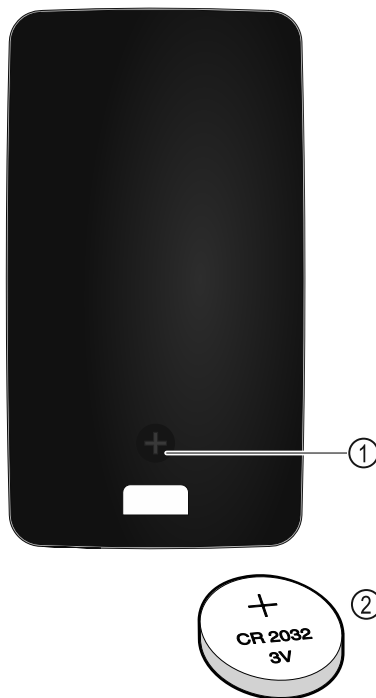

Fig. 220

The remote control is powered by a 3V CR 2032 battery Fig. 220 (2) available from specialist retailers.

8.5.1 Replacing battery

- ▶ Undo screw Fig. 220 (1) on the back of the remote control.
- ▶ Remove rear.
- ▷ Battery compartment is open.
- ▶ Replace battery.
- ▶ Close battery compartment.
- ▶ Screw back together.

Note

▶ The battery must be sent for separate waste treatment for batteries and must be disposed of in an expert and proper manner in accordance with the regulations and laws which apply locally. **Do not damage or short circuit the battery!**

9 Customer help

9.1 Technical specifications

Temperature range	
Freezing	-9 °C to -35 °C

Maximum load of grid shelves ^{A)}	Maximum load of centre grid shelf ^{A)} (see 4.15 Using equipment)
60 kg	10 kg

A) Heavier loads may result in a slight bending of the shelves.

Maximum net capacity
See net capacity on the type plate. (see 1.2 Overview of appliances and equipment)

Customer help

Lighting	
Energy efficiency class ^{A)}	Light source
This product contains one or more energy efficiency class G light sources	LED

A) The appliance may contain light sources with different energy efficiency classes. The lowest energy efficiency class is indicated.

WLAN frequency specification	
Frequency band	2.4 GHz
Maximum radiated power	<100 mW
Purpose of the wireless equipment	Integration in the local WiFi network for data communication

Set-up conditions	
Degrees of pollution (surrounding the appliance)	PD2
Ambient temperature	+10 °C to +35 °C
Maximum relative ambient moisture	75%, not condensing
Maximum operating elevation (metres above sea level)	2000 m 1500 m (glass door)

Electrical values	
Nominal voltage	220-240 V ~
Frequency	50/60 Hz
Connected load	4,0 A
Maximum mains fluctuation	+/-10%
Overvoltage categories	II

Data as per DIN 13277 measured at a reference ambient temperature of +25 °C				
Model SFPvh	Energy consumption (kWh/24h)	Temperature rise during mains failure (min)	Temperature homogeneity (°K)	Temperature constancy (°K)
1402	5.870	186 A)	1.5 B)	4.1 B)
6501	3.271	187 A)	1.9 B)	4.2 B)
8401	3.505	193 A)	2.1 B)	4.4 B)

A) Heating reference body: from -35 °C to -10 °C / reference body: 50 ml glass container filled with 50 ml isopropanol

B) Measured at reference setpoint temperature of -35 °C

Appliance battery	
Type	1S2P/NCR 18650BF
Nominal voltage	3.6 V DC
Capacity	6.7 Ah

9.2 Technical fault

Your appliance is designed and built to ensure it works reliably and has a long service life. In the unlikely event that a fault occurs during operation, please check whether the fault is due to an operating error. If this is the case, you will be charged for the cost incurred even if this falls within the warranty period.

You can fix the following faults yourself.

9.2.1 Appliance function

Defect	Cause	Remedy
The appliance is not working.	→ The appliance is not switched on.	▶ Switch on the appliance.
	→ The mains plug is not properly plugged into the socket.	▶ Check the mains plug.
	→ There is something wrong with the fuse in the socket.	▶ Check fuse.
	→ Power cut	▶ Keep the appliance closed. ▶ The door can be opened using the emergency release key. (see 7.1 Safety lock) ▶ If necessary move the refrigerated/frozen items to another fridge or freezer if the power is off for a prolonged period.
	→ The IEC socket is not plugged into the appliance correctly.	▶ Check the IEC socket.
Temperature is not cold enough.	→ The appliance door is not closed properly.	▶ Close appliance door.
	→ Ventilation is not sufficient.	▶ Clear ventilation grille and clean it.
	→ The ambient temperature is too high.	▶ Ensure the correct ambient conditions: (see 1.4 Range of use of appliance)
	→ The appliance was opened too many times or for too long.	▶ Wait to see if the appliance goes back to the required temperature by itself. If not, contact Customer Service. (see 9.3 Customer Service)

Defect	Cause	Remedy
	→ The temperature is set incorrectly.	▶ Set a colder temperature and check after 24 hours.
	→ The appliance is too close to a heat source (oven, radiator, etc).	▶ Change where the appliance or the heat source are located.
Remote control is not working.	→ The remote control battery is empty.	▶ Replace battery.
	→ The radio connection with the appliance is too weak.	▶ Reduce the distance to the appliance.
	→ Remote control not paired.	▶ Pair remote control again: (see 6.2.10 Remote control)
	→ Remote control is faulty.	▶ Contact Customer Service. (see 9.3 Customer Service)

9.3 Customer Service

First check whether you can remedy the fault yourself . If this is not the case, please contact Customer Service.

You can find the address in the enclosed brochure "Liebherr-Service" or at home.liebherr.com/service.



WARNING

Unprofessional repair!
Injuries.

- ▶ Have any repairs and action - not expressly specified - on the appliance and mains cable carried out by service personnel only. (see 8 Maintenance)
- ▶ A damaged mains cable may only be replaced by the manufacturer, the manufacturer's Customer Service or a similarly qualified person.
- ▶ In the case of appliances with an IEC connector, the change may be made by the customer.

9.3.1 Contacting Customer Service

Make sure you have the following appliance data at the ready:

- Appliance name (model and index)
- Service no. (Service)
- Serial no. (S no.)

- ▶ Access the appliance information via the display (see 6.2.20 Device information).

-or-

- ▶ Refer to the type plate for appliance information. (see 9.4 Type plate)
- ▶ Note down appliance information.
- ▶ Inform Customer Service: Report faults and the appliance information.
- ▷ This will help us to provide a fast and focussed service.
- ▶ Follow any further instructions provided by Customer Service.

9.4 Type plate

The type plate is inside the appliance. See appliance overview.

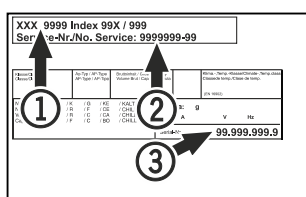

Fig. 221

- (1) Appliance designation
- (2) Service No.
- (3) Serial No.

10 Shutting down

- ▶ Empty the appliance.
- ▶ Switch off the appliance.
- ▶ Pull the mains plug out of the socket.
- ▶ Remove the IEC socket if required: Pull the IEC socket out of the appliance plug and move it to the left and right at the same time.
- ▶ Clean appliance (see 8.3 Cleaning the appliance) .
- ▶ If present: Remove the covers and insulation from the sensor feed-through to prevent mould forming.
- ▶ Leave the door open so that no bad odours form.

Note

Damage to the appliance and malfunctions!

- ▶ After shutting down, only store the appliance at the permitted room temperature of between -10 °C and +50 °C.

11 Disposal

11.1 Preparing appliance for disposal



Li-Ion

Liebherr uses batteries in some of its appliances. In the EU, for environmental reasons, legislation obliges the end user to remove these batteries before disposing of old appliances. If your appliance contains batteries, a corresponding notice is attached.

Lamps

If you can remove the lamps yourself without destroying them, also remove these before disposal.

- ▶ Take the appliance out of operation.
- ▶ Appliances with batteries: remove the batteries. For description, see **Maintenance** chapter.
- ▶ If possible: remove lamps without destroying them.

11.2 Disposing of the appliance in an environmentally friendly manner



The appliance still contains valuable materials and must be disposed of separately from unsorted municipal waste.

Additional information



Li-Ion



Li-Ion

Dispose of batteries separately from the old appliance. To do this, you can return the batteries free of charge to retailers as well as recycling centres and collection centres for recyclable materials.

Lamps

Dispose of removed lamps via the respective collection systems.

For Germany:

You can dispose of the appliance free of charge via the class 1 collection containers at the local recycling and recyclable material collection centres. When purchasing a new fridge/freezer, if the sales area > 400 m², retailers will also take back the old appliance free of charge.



WARNING

Leaking coolant and oil!

Fire. The coolant contained in the appliance is eco-friendly, but also flammable. The oil contained in the appliance is flammable. Escaping coolant and oil can ignite if the concentration is high enough and in contact with an external heat source.

- ▶ Do not damage the pipelines of the coolant circuit and the compressor.
-
- ▶ Observe the notes on transporting the appliance. (see 4.3 Transporting appliance)
 - ▶ Transport the appliance without damaging it.
 - ▶ Dispose of batteries, lamps and the appliance according to the above specifications.

12 Additional information

Further information on warranty conditions can be found in the enclosed service brochure or on the Internet at <https://home.liebherr.com>.

If appliance malfunctions, inform: _____

Model ID / Inventory number: _____

Quick Start Guide for everyday use

Information about using this Quick Start Guide:

- This Quick Start Guide is not a substitute for the full operating instructions nor is it a substitute for appliance training.
- This Quick Start Guide provides support for everyday use and handling the appliance.
- Read the full operating instructions and the safety notes contained therein.

This quick start guide is for: SFPvh 14../65../84..



Scanning the QR code will open the full operating instructions:



Intended use

This laboratory freezer is suitable for the professional storage of products at temperatures between -9 °C and -35 °C.

Foreseeable incorrect use

Do not use the appliance for the following applications:

- Storage and refrigeration of:
 - Chemically unstable, flammable or corrosive substances
 - Blood, plasma or other body fluids for the purpose of infusion, application or introduction in the human body
- Use in potentially explosive atmospheres
- Use outdoors or in areas exposed to dampness and splashing water

When stocking, observe the following points:

- Position grid shelves according to the height required.
- Observe maximum load.
- When the storage temperature has been reached, load the appliance (compliance with cold chain).
- Produce for cooling must not come into contact with the evaporator on the rear wall.
- Keep liquids in closed containers.
- Leave space when storing refrigerated goods to ensure good air circulation.

Status display



Fig. 222

- (1) Actual temperature (3) Defrosting status
 (2) Alarm status (4) Door lock status

Displaying temperature recording

The temperature recording displays the length of the recording and the minimum and maximum temperatures measured during this period of time.



Fig. 223

Resetting temperature recording

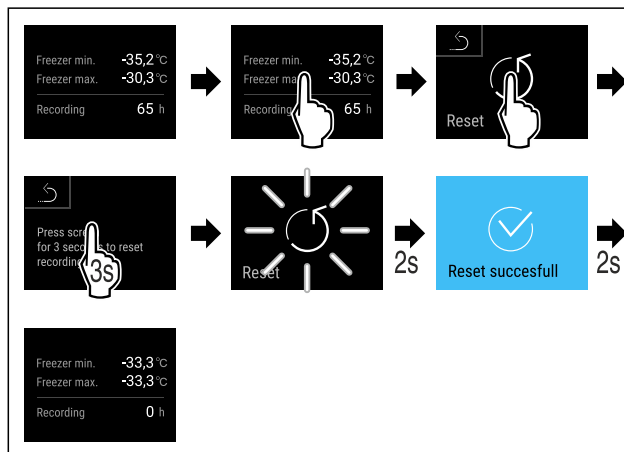

Fig. 224

Displaying alarm log

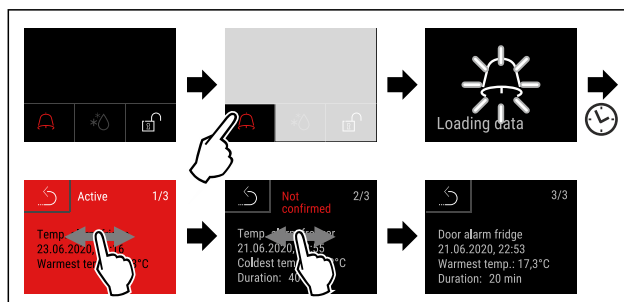

Fig. 225 Example shows an active alarm, an unconfirmed alarm, and a confirmed alarm.

- ▷ Alarm log shows active, confirmed or unconfirmed alarms (maximum 10 alarms).
- ▷ To delete the alarm log: See operating instructions.

Cleaning appliance

- ▶ Empty the appliance.
- ▶ Pull out the mains plug.
- ▶ Observe the information in the operating instructions.
- ▶ Dry the appliance and equipment thoroughly after cleaning.
- ▶ Connect the appliance.
- ▶ Switch on the appliance.
- ▶ Load the appliance once the storage temperature is reached.



What should I do if there is a fault?

A message appears in the display if there is a fault. Messages have different meanings:

Quick Start Guide for everyday use

Symbol colour in the display	Meaning	Remedy
YELLOW	Reminder Reminder of general procedures. You can carry out these procedures to eliminate the message.	Consult the operating instructions and perform the troubleshooting steps.
RED	Warning Appears when there are malfunctions. You can eliminate simple malfunctions yourself.	Consult the operating instructions and perform the troubleshooting steps.

If you cannot remedy the fault yourself, contact a competent member of staff or your nearest customer service outlet.

Cut out the page





home.liebherr.com/fridge-manuals

EN Freezer
ORIGINAL OPERATOR'S MANUAL

Issue date: 20240605

Part number index: 7083320-00

Liebherr Hausgeräte Lienz GmbH
Dr.-Hans-Liebherr-Strasse 1
A-9900 Lienz
Österreich

