

# SUIG 1514

Built-under freezer for integrated use



**LIEBHERR**

Fully Integrated

**LIEBHERR**

# SUIG 1514

Built-under freezer for integrated use



↑  
**82-88**  
↓



Type	Fixed door / Under-worktop appliance for integrated use
Energy consump. in 365 days/24 h	168 kWh
Total net capacity	95 l
Climate rating	SN-T (+10 °C to +43 °C)
Frequency / voltage	50 Hz / 220-240 V-
Connection Rating	1.3 A
Aperture dimensions in cm (h / w / d)	82-88 / 60 / min. 55
<b>Controls</b>	
Type of Control	MagicEye, key electronic Digital temperature display
Door alarm	visual and acoustic
Alarm in case of malfunction	visual and acoustic
<b>Freezer compartment</b>	
Star coding	****
Number of drawers	3 drawers, VarioSpace
Freezing capacity in 24 hours	5.7 kg
Temperature rise time	10.05 h
VarioSpace	yes
<b>Features</b>	
Side-by-Side concept	Side-panel heating on both sides, suitable for combination with other fridges, freezers and/or wine appliances
Door hinges	Reversible door hinge, left
EAN-Nr.	4016803122340

## Features

---



### SmartFrost

Compared to other static freezers, Liebherr's SmartFrost technology freezes food faster, and reduces ice build-up, making defrosting simpler and quicker. It also provides a more flexible storage area with greater capacity and improved energy consumption for lower running costs.

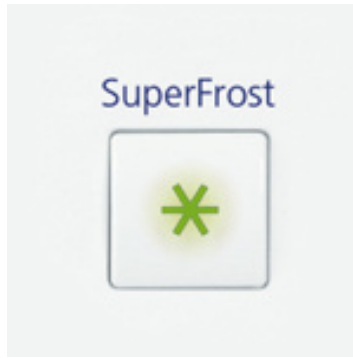

### Automatic SuperFrost function

The automatic SuperFrost function makes freezing simple and saves energy. It quickly reduces the temperature to  $-32\text{ }^{\circ}\text{C}$  and thus creates the cold air required to preserve vital vitamins. As soon as the food is completely frozen, the automatic SuperFrost function switches back to normal mode after max. 65 hours, and thus assists in saving electricity.

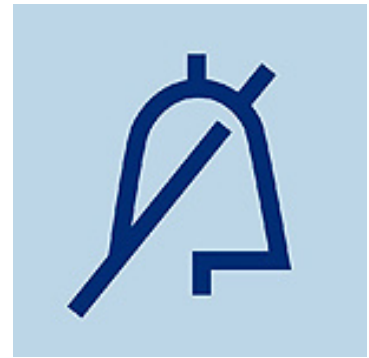

### Door alarm

The audible door alarm alerts the user if the door has been open for longer than 60 seconds for safe protection of the food.



### FrostSafe

With the FrostSafe, the extra-high and removable drawers are closed all round. This means that the cold cannot dissipate so quickly when the appliance is opened. The transparent front of the compartments guarantees an optimum overview of the frozen items.



### VarioSpace

All freezers with NoFrost and SmartFrost feature drawers and intermediate glass shelves underneath them which can be conveniently removed. This results in VarioSpace – the practical system for extra storage space so that space can be created quickly even for larger frozen food items.



### Reversible door hinges

It is possible to change the door hinge on the appliance. The reversible door hinges permit optimum use of the appliance wherever it is located.

# Technical drawing

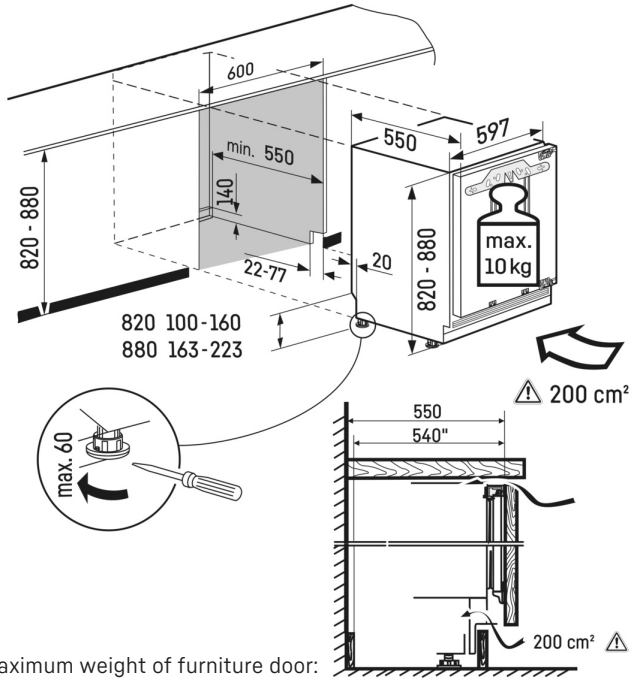

Maximum weight of furniture door:  
Freezer compartment: 10 kg

Products and their details are staged for advertising purposes. Whilst every effort is made to ensure all specifications and information in this flyer are accurate, Liebherr reserves the right to make changes without notification. Where actual appliance measurements, specifications, and ratings are crucial, we recommend that the actual appliance installation instructions that accompany each appliance be checked. Liebherr will not be liable for any damage. (06.04.2023)

